

2022

[HOTSY.COM](https://www.hotsy.com)

# EVERYTHING HOTSY

PRESSURE WASHERS // FLOOR CARE // DETERGENTS // PARTS & ACCESSORIES

**hotsy**®

PRESSURE WASHERS // EST. 1970





## It's the Brand the Pros Use!

Hotsy Pressure Washers are used in countless commercial applications throughout North America. Professionals have come to trust the ruggedness and dependability that Hotsy offers. We have portable, stationary, trailer units, electric, gas & oil fired washers. No matter what your cleaning job is, you'll find a Hotsy ready to take on that job.

**Hotsy is the clear choice** – quality equipment built for long-lasting performance.



HOTSY.COM



**JOIN OUR EMAIL LIST.**  
Be the first to hear about  
Hotsy deals. Scan the code or visit  
<http://bit.ly/GetHotsy>

IT'S WHAT THE **PROS** USE!





## TABLE OF CONTENTS

---

HOT WATER PRESSURE WASHERS	2
HEATING MODULES	15
TRAILERS	16
COLD WATER PRESSURE WASHERS	17
WATER RECOVERY	29
DETERGENT	30
FLOOR CARE	44
HOTSY BRANDED PARTS	89
PRESSURE WASHER ACCESSORIES	111
GUNS & LANCES	127
HOSES	136
COUPLERS, FITTINGS & FILTERS	145
NOZZLES	163
PUMPS & PUMP KITS	181
UNLOADERS, INJECTORS, VALVES & GUAGES	213
ENGINES, MOTORS & PULLEYS	238
BURNERS	245
ELECTRICAL COMPONENTS	261
CHASSIS COMPONENTS	275
CAR WASH BAY ACCESSORIES	278
AG SPRAY ACCESSORIES	285
INDEX	292

---



### MAX STOCK SYMBOL

Fast shipping available. We strive to keep popular items stocked & available at all times.

## HOT WATER PRESSURE WASHERS / ELECTRIC

- Oil-Fired
- 1.7 GPM @ 1200 PSI
- Auto Start/Stop

# 333

The 333 Model is a competitively priced, entry-class hot water pressure washer. Innovative upright design ensures good mobility and ergonomics, while its compact size makes it easy to transport both horizontally and vertically. Built-in 3 angle spray nozzle and low pressure chemical application. Very user-friendly with one-switch operation and areas for hose and accessory storage. This model is ETL safety certified and comes equipped with a 33' high-pressure hose, lance, trigger gun and 16' power cord.



MODEL	PART NO.	GPM	PSI	HP	VOLT/PH	AMPS	FUEL	BTU/HR	PUMP MODEL	PORTABILITY	DIMENSIONS (LXWXH)	SHIP WT (LBS)
333	1.064-049.0	1.7	1200	2.3	115/1	12.5	Oil	80,000	Axial	Std	28"x28"x46"	178

### OPTIONS

PART NO.	DESCRIPTION
2.642-305.0	Gutter cleaning lance <i>(image 1 below)</i> ▶
4.760-245.0	Underbody lance <i>(image 2 below)</i> ▶
2.883-803.0	Power nozzle for underbody lance, 25° spray angle ▶
6.390-025.0	33' high pressure hose ▶
6.401-459.0	Plug nipple ▶
6.390-028.0	Pipe cleaning hose ▶
4.762-010.0	Wet blasting attachment <i>(image 3 below)</i> ▶
2.638-526.0	Nozzle kit for wet blasting attachment ▶
2.640-355.0	FR30Me surface cleaner <i>(image 4 below)</i> ▶
2.640-482.0	Nozzle kit for surface cleaner FR ▶
3.637-170.0	Detergent injector for high pressure ▶

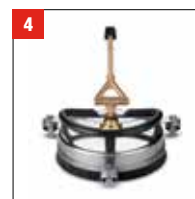
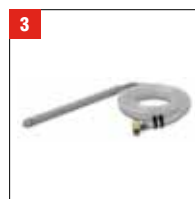

▶ Field Installed    ▶ Factory Installed

### LEGEND

- ▶ **Factory Installed Options** must be ordered with the machine. They are installed in factory.
- ▶ **Field Installed Options** can be added to a machine at any time. They are installed by the Dealer.



- Oil-Fired
- 120V
- Stainless Steel Coil Skin
- Flat-Free Tires for Easy Handling

**555HE NOW COMES WITH AUTO START/STOP STANDARD!**

# 500 SERIES & 680SS

**DIRECT DRIVE**

The 500 Series delivers rugged, yet affordable, cleaning performance for a broad range of applications. The new 555HE is the most efficient hot water pressure washer in our line. It features a technologically advanced heat exchanger that takes water to higher temperatures much faster, saving time and money. All models are ETL safety certified and feature the Hotsy pump backed by a full 7-year limited warranty. All models come equipped with a 50' high-pressure hose, lance, nozzles and trigger gun.



Model 555HE



MODEL	PART NO.	GPM	PSI	HP	VOLT/PH	AMPS	FUEL	BTU/HR	PUMP MODEL	PORTABILITY	DIMENSIONS (LXWXH)	SHIP WT (LBS)
555HE	1.109-137.0	2.2	1300	2	120/1	20	Oil	185,000	Triplex - HE2126S	Std	42"x29"x42"	385
555SS	1.109-033.0	2.2	1300	2	115/1	20	Oil	214,300	Duplex - HHC165L.1	Std	33"x27"x41.5"	400
560SS	1.109-034.0	2.1	1500	2.3	115/1	20	Oil	214,300	Triplex HF2030SL	Std	33"x26"x44"	405
680SS	1.109-035.0	3	1000	2	115/1	20	Oil	289,900	Triplex - HF2830S	Std	33"x27"x45.5"	440

HE = High Efficiency    SS = Stainless Steel

OPTIONS	
PART NO.	DESCRIPTION
8.717-764.0	8" Oil-Fired Vent Regulator
8.929-192.0	Float Tank (555HE Only)
8.750-486.0	360° Pivot Reel, 100'
8.903-050.0	100' 3/8" Hose Reel Kit (555SS Only)
8.929-363.0	Exhaust Adapter* (555HE Only)

OPTIONS	
PART NO.	DESCRIPTION
9.804-624.0	QC Nozzle 3.75, 15° (Yellow) (555HE Only)
9.804-625.0	QC Nozzle 3.75, 25° (Green) (555HE Only)
9.804-626.0	QC Nozzle 3.75, 40° (White) (555HE Only)
8.903-034.0	Float Tank Kit (555SS Only)

▶ Field Installed    ◀ Factory Installed

\* NOTE: Must be ordered if the vent regulator [8.717-764.0] is used or the machine is connected to an exhaust stack



Model 680SS



Model 555SS

## HOT WATER PRESSURE WASHERS / ELECTRIC

- Oil-Fired
- TEFC Motor
- Flat-Free Tires for Easy Handling
- Stainless Steel Coil Skin

# 700 SERIES & 895SS

## BELT DRIVE

The 700 Series offers a nice balance of Hotsy ruggedness and cleaning performance, yet the affordability of an entry-level machine. More powerful yet is the 895SS. The 700 series is ideal for meeting the needs of commercial customers. All models are ETL safety certified and feature the Hotsy pump backed by a full 7-year limited warranty. All models come equipped with a 50' high-pressure hose, lance, nozzles and trigger gun.

Model 795SS



MODEL	PART NO.	GPM	PSI	HP	VOLT/PH	AMPS	FUEL	BTU/HR	PUMP MODEL	DRIVE	PORTABILITY	DIMENSIONS (LXWXH)	SHIP WT (LBS)
790SS	1.109-612.0	3.0	2000	4	230/1	20	Oil	289,900	HB4025R	Belt	Std	37"x28"x45.5"	450
795SS	1.109-039.0	3.5	2000	5	230/1	24	Oil	289,900	HB4025R	Belt	Std	37"x28"x45.5"	455
795SS-208	1.109-040.0	3.5	2000	5	208/1	27	Oil	289,900	HB4025R	Belt	Std	37"x28"x45.5"	500
895SS	1.109-077.0	3.5	3000	8.2	230/1	36	Oil	289,900	HM3540R.3	Belt	Std	37"x28"x45.5"	480

SS = Stainless Steel

### OPTIONS

PART NO.	DESCRIPTION	LIST PRICE
8.717-764.0	8" Oil-Fired Vent Regulator	▶
8.750-486.0	360° Pivot Reel, 100'	▶
8.750-483.0	360° Pivot Reel, 200'	▶
8.903-050.0	100' 3/8" Hose Reel Kit (790SS Only)	▶

▶ Field Installed    ▶ Factory Installed



Model 895SS

- ❑ Oil-Fired
- ❑ Big & Beefy, Yet Easy To Maneuver
- ❑ Rugged Hotsy Pump with 7-Year Limited Warranty
- ❑ Stainless Steel Coil Skin

# 800 SERIES

## BELT DRIVE

Rugged design, easy maneuverability and massive cleaning power. Comparable to the cleaning power of Hotsy's heavy-duty stationary units, the big and beefy 800 Series is surprisingly easy to maneuver into place, allowing you to tackle the heaviest of industrial cleaning jobs. The 28" wide wheel base helps with stability, yet is narrow enough to fit easily through doorways. Components are protected by an easy-to-remove cover allowing servicing access. All models are ETL safety certified and feature the Hotsy pump backed by a full 7-year limited warranty. All models come equipped with a 50' high-pressure hose, lance, nozzles and trigger gun.

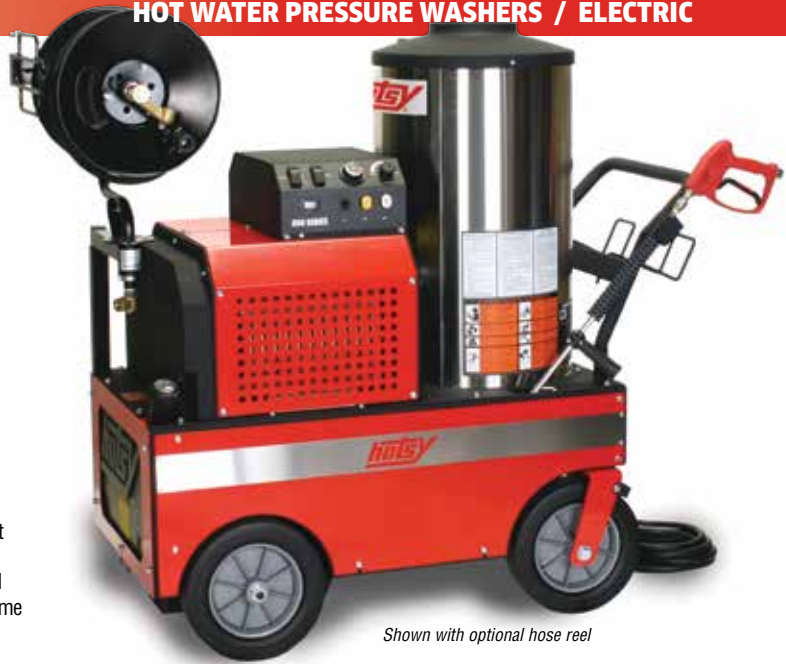

*Shown with optional hose reel*

U.S. Design Patent No. 726,382 S



*Optional Detergent Bucket Bracket*

MODEL	PART NO.	GPM	PSI	HP	MOTOR RPM	VOLT/ PH	AMPS	FUEL	BTU/HR	PUMP MODEL	PORTABILITY	DIMENSIONS (LXWXH)	SHIP WT (LBS)
821	1.109-120.0	4.0	2300	6.2	3450	208/1	33	Oil	381,000	HM4045R.3	Std	51"x28"x51"	632
842	1.109-121.0	4.0	2000	5	1725	208/3	20	Oil	381,000	HM4030R.3	Std	51"x28"x51"	622
843	1.109-122.0	4.0	2000	5	1725	230/1	29	Oil	381,000	HM4030R.3	Std	51"x28"x51"	622
844	1.109-123.0	4.0	2000	5	1725	230/3	19	Oil	381,000	HM4030R.3	Std	51"x28"x51"	622
845	1.109-124.0	4.0	2000	5	1725	460/3	10	Oil	381,000	HM4030R.3	Std	51"x28"x51"	691
851	1.109-125.0	4.0	3000	8.2	3450	208/1	44	Oil	381,000	HM4045R.3	Std	51"x28"x51"	675
852	1.109-126.0	4.0	3000	7.5	1725	208/3	25	Oil	381,000	HM4030R.3	Std	51"x28"x51"	665
853	1.109-127.0	4.0	3000	7.5	1725	230/1	37	Oil	381,000	HM4030R.3	Std	51"x28"x51"	665
854	1.109-128.0	4.0	3000	7.5	1725	230/3	25	Oil	381,000	HM4030R.3	Std	51"x28"x51"	665
855	1.109-129.0	4.0	3000	7.5	1725	460/3	14	Oil	381,000	HM4030R.3	Std	51"x28"x51"	665
856	1.109-130.0	4.0	3000	8.2	3450	575/3	11	Oil	381,000	HM4045R.3	Std	51"x28"x51"	680
873	1.109-131.0	5.0	3000	10	1725	230/1	42	Oil	404,000	HM4030R.3	Std	51"x28"x51"	670
874	1.109-132.0	5.0	3000	10	1770	230/3	29	Oil	404,000	HM4030R.3	Std	51"x28"x51"	675

OPTIONS	
PART NO.	DESCRIPTION
8.930-170.0	Auto Start/Stop Kit* ▶
8.930-172.0	Thermal Shutdown Kit ▶
8.930-171.0	Time Delay Shutdown* ▶
8.717-764.0	8" Oil-Fired Vent Regulator ▶

OPTIONS	
PART NO.	DESCRIPTION
8.750-486.0	360° Pivot Reel, 100' ▶
8.750-483.0	360° Pivot Reel, 200' ▶
8.754-435.0	Pneumatic Wheel ▶
8.923-225.0	Detergent Bucket Bracket ▶

\* Note: Time Delay Shutdown and Auto Start/Stop cannot be combined on the same machine.

▶ Field Installed    ▶ Factory Installed



## HOT WATER PRESSURE WASHERS / ELECTRIC

- NG- or LP-Fired
- 115V/1PH or 230V/1 PH
- Hotsy Direct-Drive Pump
- Flat-Free Tires for Easy Handling

# LP/NG SERIES

## DIRECT DRIVE

These hot water washers are heated with either LP or NG, and offer cleaning power up to 1500 PSI. All models are ETL safety certified and feature the Hotsy pump backed by a full 7-year limited warranty. All models come equipped with a 50' high-pressure hose, lance, nozzles and trigger gun.

Model 771-Propane (shown with optional Portagear & Propane Tank)



Model 558-Propane (shown with optional Portagear & propane tank)



MODEL	PART NO.	GPM	PSI	HP	VOLT/PH	AMPS	FUEL	BTU/HR	PUMP MODEL	DRIVE	DIMENSIONS (LXWXH)	SHIP WT (LBS)
558	1.109-610.0	2.2	1300	2	115/1	18	LP	214,300	Duplex - HHC165L.1	Direct	31.5"x26"x41"	350
771	1.109-611.0	3.0	1500	3	230/1	13	LP	280,000	HF2830S	Direct	32"x27"x45.5"	415
772	1.109-037.0	3.0	1500	3	230/1	13	NG	338,000	HF2830S	Direct	32"x27"x45.5"	415

Portability is optional on these models unless ordered with the portagear kit PN 8.903-049.0.

### OPTIONS

PART NO.	DESCRIPTION
8.717-728.0	8" LP Gas-Fired Draft Diverter
8.903-049.0	Portagear
8.717-791.0	Propane Tank, 43 lb. (Model 558 & 771)

Field Installed    Factory Installed

- LP-or Natural Gas-Fired
- Hotsy Belt-Drive Pump
- Remote-Ready

- Smart Relay Control provides control over run time, auto start/stop and shut down functionality

# 900/1400 SERIES

## BELT DRIVE

Hotsy's 900/1400 Series of innovative stationary models are packed with standard features! The most impressive is the programmable smart control automation. Safety is key with a pressure relief valve and locking lid and side panels around the belt and pulleys to keep users safe. These electric-powered washers are available in either LP or Natural Gas fired models. New models have the same footprint as previous generations, so users can feel confident about upgrading. Panels may be easily removed for access to the machine components for servicing. All models are ETL safety certified and feature the Hotsy pump backed by a full 7-year limited warranty. All models come equipped with a 50' high-pressure hose, lance, nozzles and trigger gun.



### U.S. Design Patent No. 740,501 S

MODEL	PART NO.	GPM	PSI	HP	MOTOR RPM	VOLT/PH	AMPS	FUEL	BTU/HR	PUMP MODEL	DIMENSIONS (LXWXH)	SHIP WT (LBS)
921P	1.109-948.0	4.0	2300	6.2	3450	208/1	32	LP	364,835	HM4030R.3	47.5"x21"x51"	700
921N	1.109-691.0	4.0	2300	6.2	3450	208/1	32	NG	364,835	HM4030R.3	47.5"x21"x51"	700
926P	1.109-949.0	4.0	2000	5	1800	575/3	7	LP	364,835	HM4030R.3	47.5"x21"x51"	660
926N	1.109-692.0	4.0	2000	5	1800	575/3	7	NG	364,835	HM4030R.3	47.5"x21"x51"	660
942P	1.109-693.0	4.0	2000	5	1725	208/3	18	LP	360,997	HM4030R.3	47.5"x21"x51"	590
942N	1.109-694.0	4.0	2000	5	1725	208/3	18	NG	364,835	HM4030R.3	47.5"x21"x51"	655
943P	1.109-695.0	4.0	2000	5	1725	230/1	25	LP	360,997	HM4030R.3	47.5"x21"x51"	685
943N	1.109-696.0	4.0	2000	5	1725	230/1	25	NG	364,835	HM4030R.3	47.5"x21"x51"	685
944P	1.109-697.0	4.0	2000	5	1725	230/3	16	LP	360,997	HM4030R.3	47.5"x21"x51"	580
944N	1.109-698.0	4.0	2000	5	1725	230/3	16	NG	364,835	HM4030R.3	47.5"x21"x51"	680
945P	1.109-699.0	4.0	2000	5	1725	460/3	8	LP	360,997	HM4030R.3	47.5"x21"x51"	585
945N	1.109-700.0	4.0	2000	5	1725	460/3	8	NG	364,835	HM4030R.3	47.5"x21"x51"	670
MODEL	PART NO.	GPM	PSI	HP	MOTOR VRPM	VOLT/PH	AMPS	FUEL	BTU/HR	PUMP MODEL	DIMENSIONS (LXWXH)	SHIP WT (LBS)
1451P	1.109-950.0	4.0	3000	8.2	3450	208/1	39	LP	364,835	HM4030R.3	47.5"x21"x51"	730
1451N	1.109-701.0	4.0	3000	8.2	3450	208/1	39	NG	364,835	HM4030R.3	47.5"x21"x51"	730
1452P	1.109-702.0	4.0	3000	7.5	1725	208/3	24	LP	360,997	HM4030R.3	47.5"x21"x51"	625
1452N	1.109-703.0	4.0	3000	7.5	1725	208/3	24	NG	364,835	HM4030R.3	47.5"x21"x51"	625
1453P	1.109-704.0	4.0	3000	7.5	1725	230/1	34	LP	360,997	HM4030R.3	47.5"x21"x51"	735
1453N	1.109-705.0	4.0	3000	7.5	1725	230/1	34	NG	364,835	HM4030R.3	47.5"x21"x51"	735
1454P	1.109-706.0	4.0	3000	7.5	1725	230/3	24	LP	360,997	HM4030R.3	47.5"x21"x51"	625
1454N	1.109-707.0	4.0	3000	7.5	1725	230/3	24	NG	364,835	HM4030R.3	47.5"x21"x51"	700
1455P	1.109-708.0	4.0	3000	7.5	1725	460/3	12	LP	360,997	HM4030R.3	47.5"x21"x51"	630
1455N	1.109-709.0	4.0	3000	7.5	1725	460/3	12	NG	364,835	HM4030R.3	47.5"x21"x51"	780
1456P	1.109-951.0	4.0	3000	8.2	3450	575/3	10	LP	364,835	HM4030R.3	47.5"x21"x51"	621
1456N	1.109-710.0	4.0	3000	8.2	3450	575/3	10	NG	364,835	HM4030R.3	47.5"x21"x51"	621
1473P	1.109-711.0	5.0	3000	10	1725	230/1	42	LP	378,617	HM4035R.3	47.5"x21"x51"	735
1473N	1.109-713.0	5.0	3000	10	1725	230/1	42	NG	390,025	HM4035R.3	47.5"x21"x51"	735
1474P	1.109-712.0	5.0	3000	10	1770	230/3	29	LP	378,617	HM4035R.3	47.5"x21"x51"	740
1474N	1.109-714.0	5.0	3000	10	1770	230/3	29	NG	390,025	HM4035R.3	47.5"x21"x51"	740
1475P	1.109-952.0	5.0	3000	10	1725	208/3	34	LP	378,617	HM4030R.3	47.5"x21"x51"	740
1475N	1.109-953.0	5.0	3000	10	1725	208/3	34	NG	378,617	HM4030R.3	47.5"x21"x51"	740

# 900/1400 SERIES OPTIONS



OPTIONS	
PART NO.	DESCRIPTION
8.916-989.0	Remote Station <i>(image 1 above)</i>
8.916-988.0	Soap Solenoid and Switch
8.717-728.0	8" Natural Gas- or LP Gas-Fired Draft Diverter
9.803-452.0	Water Inlet Solenoid
8.755-253.0	8" Power Dampener
8.749-807.0	Power Dampener Wiring Harness

OPTIONS	
PART NO.	DESCRIPTION
8.924-814.0	R-Con Wireless Remote Kit (1 remote/1 receiver) <i>(image 2 above)</i>
8.925-072.0	R-Con Wireless Remote Kit (2 remotes/1 receiver)
8.924-878.0	Wall Mount Remote Bracket for R-Con <i>(image 3 above)</i>
8.756-329.0*	Replacement Remote (transmitter only)

▶ Field Installed    ▶ Factory Installed

\* **Please Note: R-Con Wireless Remote** comes from vendor, is custom made to order and is not universal. When ordering, please contact customer service to supply the serial number off the transmitter you have along with the channel number, so we can pass along that information to the vendor.



- Natural Gas, Oil or optional LP-Fired
- Remote-ready
- Hotsy Belt Drive Pump
- Stainless Steel Coil Skin
- Smart Relay Control provides control over run time, auto start/stop and shut down functionality

# 1800 SERIES

## BELT DRIVE

The 1800 Series provides stationary cleaning with hot water indoors. The 7 models are electric-powered and natural gas, oil or optional LP gas-heated. The coil skin comes standard with stainless steel. The sleek cabinet has removable side and front panels, making it easy for routine scheduled maintenance and service. The Smart Relay allows the washer to be customized to individual needs, and is protected behind the front panel. All models are ETL safety certified and feature the Hotsy pump backed by a full 7-year limited warranty. All models come equipped with a 50' high-pressure hose, lance, nozzles and trigger gun.



MODEL	PART NO.	GPM	PSI	HP	VOLT/PH	AMPS	FUEL	BTU/HR	PUMP MODEL	DIMENSIONS (LXWXH)	SHIP WT (LBS)
1812SS	1.109-660.0	6.0	2500	10	230/1	42	NG	558,050	HX9536L.2	51"x31"x53.25"	1,020
1830SS	1.109-665.0	6.0	3000	15	230/3	40	Oil*	579,776	HX9536L.2	51"x31"x53.25"	1,020
1832SS	1.109-662.0	6.0	3000	15	230/3	38	NG	558,050	HX9536L.2	51"x31"x53.25"	1,020
1832SS-208	1.109-661.0	6.0	3000	15	208/3	41	NG	558,050	HX9536L.2	51"x31"x53.25"	1,020
1833SS	1.109-666.0	6.0	3000	15	460/3	21	Oil*	579,776	HX9536L.2	51"x31"x53.25"	1,020
1835SS	1.109-663.0	6.0	3000	15	460/3	19	NG	558,050	HX9536L.2	51"x31"x53.25"	1,020
1836SS	1.109-664.0	6.0	3000	15	575/3	16	NG	558,050	HX9536L.2	51"x31"x53.25"	1,020

\*Oil-fired models are not supplied with a fuel tank

OPTIONS	
PART NO.	DESCRIPTION
8.916-989.0	Remote Station (image 1 below)
8.916-988.0	Soap Solenoid and Switch
8.749-806.0	10" Power Dampener
8.749-807.0	Power Dampener Wiring Harness
9.801-040.0	10" Natural Gas- or LP Gas-Fired Draft Diverter

OPTIONS	
PART NO.	DESCRIPTION
9.803-452.0	Water Inlet Solenoid
8.924-814.0	R-Con Wireless Remote Kit (1 remote /1 receiver) (image 2 below)
8.925-072.0	R-Con Wireless Remote Kit (2 remotes/1 receiver)
8.924-878.0	Wall Mount Remote Bracket for R-Con (image 3 below)
8.756-329.0*	Replacement Remote (transmitter only)
8.903-074.0	LP Conversion Kit



▶ Field Installed    ▶ Factory Installed

\* **Please Note: R-Con Wireless Remote** comes from vendor, is custom made to order and is not universal. When ordering, please contact customer service to supply the serial number off the transmitter you have along with the channel number, so we can pass along that information to the vendor.

## HOT WATER PRESSURE WASHERS / ELECTRIC

- Oil, Natural Gas or optional LP-Fired
- Remote-ready
- Hotsy Belt Drive Pump
- Stainless Steel Coil Skin
- Smart Relay Control provides control over run time, auto start/stop and shut down functionality

# 5700/5800 SERIES

## BELT DRIVE

The 5700 and 5800 Series produces a powerful punch and is ideal for wash bay installations. With its 20 HP motor driving the incomparable Hotsy Triplex Pump and a vertical banded belt, the 5700 and 5800 Series delivers cleaning power up to 9.5 GPM and 3000 PSI. Has a sleek cabinet with removable panels for easy access for maintenance. A removable control panel provides access to the adjustable temperature control and the Smart Relay for secured control of operating positions. Remote ready for wash bay installations. All models are ETL safety certified and feature the Hotsy pump backed by a full 7-year limited warranty. All models come equipped with a 50' high-pressure hose, lance, nozzles and trigger gun.



MODEL	PART NO.	GPM	PSI	HP	VOLT/PH	AMPS	FUEL	BTU/HR	PUMP MODEL	HOSE (FT)	DIMENSIONS (LXWXH)	SHIP WT (LBS)
5730SS	1.109-658.0	8.0	3000	20	230/3	44	Oil*	768,000	HX9536L.2	50	51"x31"x63.4"	1,471
5732SS-208	1.109-654.0	8.0	3000	20	208/3	55	NG	720,450	HX9536L.2	50	51"x31"x63.4"	1,471
5732SS	1.109-655.0	8.0	3000	20	230/3	42	NG	720,450	HX9536L.2	50	51"x31"x63.4"	1,471
5733SS	1.109-659.0	8.0	3000	20	460/3	23	Oil*	768,000	HX9536L.2	50	51"x31"x63.4"	1,471
5735SS	1.109-656.0	8.0	3000	20	460/3	21	NG	720,450	HX9536L.2	50	51"x31"x63.4"	1,471
5736SS	1.109-657.0	8.0	3000	20	575/3	16	NG	720,450	HX9536L.2	50	51"x31"x63.4"	1,471
5832SS	1.109-651.0	9.5	2500	20	230/3	42	NG	939,890	HX1036L.2	50	51"x31"x63.4"	1,471
5832SS-208	1.109-650.0	9.5	2500	20	208/3	48	NG	939,890	HX1036L.2	50	51"x31"x63.4"	1,471
5835SS	1.109-652.0	9.5	2500	20	460/3	21	NG	939,890	HX1036L.2	50	51"x31"x63.4"	1,461
5836SS	1.109-653.0	9.5	2500	20	575/3	16	NG	939,890	HX1036L.2	50	51"x31"x63.4"	1,471

\*Oil-fired models are not supplied with a fuel tank

### OPTIONS

PART NO.	DESCRIPTION
8.753-171.0	12" Power Dampener
8.749-807.0	Power Dampener Wiring Harness
9.803-452.0	Water Inlet Solenoid
8.916-989.0	Remote Station (image 1 below)
8.916-988.0	Soap Solenoid and Switch
8.717-730.0	12" Natural Gas- or LP Gas-Fired Draft Diverter

### OPTIONS

PART NO.	DESCRIPTION
8.924-814.0	R-Con Wireless Remote Kit (1 remote/1 receiver) (image 2 below)
8.925-072.0	R-Con Wireless Remote Kit (2 remotes/1 receiver)
8.924-878.0	Wall Mount Remote Bracket for R-Con (image 3 below)
8.756-329.0 *	Replacement Remote (transmitter only)
8.916-916.0	LP Conversion Kit, 5700
8.916-915.0	LP Conversion Kit, 5800

▶ Field Installed    ▶ Factory Installed

\* **Please Note: R-Con Wireless Remote** comes from vendor, is custom made to order and is not universal. When ordering, please contact customer service to supply the serial number off the transmitter you have along with the channel number, so we can pass along that information to the vendor.



- Oil-Fired
- 12 Volt DC
- Hotsy Direct-Drive Pump
- Stainless Steel Coil Skin
- 3 Battery-less Models
- 2 Electric-Start Models
- Flat-Free Tires for Easy Handling

# GAS ENGINE SERIES

## DIRECT DRIVE

The Gas Engine Series consists of the most compact and portable hot water pressure washers on the market. Powered by reliable gasoline engines, all you need is water and you can clean anywhere anytime. The five models offer a broad range of cleaning power, from 2.7 to 4.0 GPM and from 2400 to 3500 PSI. All models are ETL safety certified and feature the Hotsy pump backed by a full 7-year limited warranty. All models come equipped with a 50' high-pressure hose, lance, nozzles and trigger gun.



965SS



871SS



1075SSE



MODEL	PART NO.	GPM	PSI	ENGINE/ MODEL	CARB COMP.	CCs	BURNER	BTU/HR	PUMP MODEL	PORT- ABILITY	DIMENSIONS (LXWXH)	SHIP WT (LBS)
871SS*	1.110-014.0	2.7	2400	Honda GX200	YES	196	12V DC	248,500	HP3035G	Std	43"x27"x39"	410
965SS*	1.110-015.0	3.0	3000	Honda GX270	NO ★	270	12V DC	248,500	HP3035G	Std	47"x31"x41"	445
965SS CAL*	1.110-090.0	3.0	3000	Vanguard 400	YES	408	12V DC	248,500	HP3035G	Std	47"x31"x41"	445
1065SS*	1.110-010.0	3.5	3000	Honda GX340	NO ★	337	12V DC	309,900	HS3540G.3	Std	47"x31"x45"	495
1065SSE†	1.110-011.0	3.5	3000	Honda GX340	NO ★	337	12V DC	309,900	HS3540G.3	Std	47"x31"x45"	510
1065SSE CAL†	1.110-089.0	3.5	3000	Vanguard 400	YES	408	12V DC	309,900	HS3540G.3	Std	47"x31"x45"	510
1075SSE†	1.110-012.0	4.0	3500	Honda GX390	NO ★	389	12V DC	309,900	HS4040G.3	Std	47"x31"x45"	520
1075SSE CAL†	1.110-080.0	4.0	3500	Vanguard 400	YES	408	12V DC	309,900	HS4040G.3	Std	47"x31"x45"	520

\*Battery not required  
 † 12V battery required, but not supplied  
 E = Electric-start engine

★ CARB Compliance required for sale in California.



## HOT WATER PRESSURE WASHERS / GAS

- Oil-Fired
- 12 Volt DC
- Hotsy Belt-Drive Pump
- 2 Electric-Start Models

# GAS ENGINE SERIES

## BELT DRIVE

The belt drive versions of the Gas Engine Series provide versatility with the roll cage design. Designed to fit the needs of the end-user, this versatile hot water washer converts easily to a skid unit, portable with wheels or a wheel/caster kit, or can be mounted on a trailer. Powered by reliable gasoline engines, the three models offer a broad range of cleaning power, from 3.0 to 4.6 GPM and from 3000 to 3500 PSI. All models are ETL safety certified and feature the Hotsy pump backed by a full 7-year limited warranty. All models come equipped with a 50' high-pressure hose, lance, nozzles and trigger gun.



1075BE  
(shown with optional  
caster wheel kit)



965B (shown with optional  
flat-free tires)



1080BE (shown with optional stainless  
steel coil wrap and skid rails)



MODEL	PART NO.	GPM	PSI	ENGINE MODEL	CARB COMP.	CCs	BURNER	BTU/HR	PUMP MODEL	PORTABILITY	DIMENSIONS (LXWXH)	SHIP WT (LBS)
965B*	1.110-565.0	3.0	3000	Honda GX270	NO ★	270	12V DC	248,500	HB3030L.1	Optional	42"x27.5"x39"	590
1075BE†	1.110-566.0	4.0	3500	Honda GX390	NO ★	389	12V DC	385,800	HM4035L.3	Optional	42"x27.5"x39"	625
1075BE†	1.110-082.0	4.0	3500	Vanguard 400	YES	408	12V DC	385,800	HM4035L.3	Optional	42"x27.5"x39"	625
1080BE†	1.110-567.0	4.6	3500	Vanguard 18		570	12V DC	385,800	HM4035L.3	Optional	42"x27.5"x39"	665

\* Battery not required

E = Electric-start engine

† 12V battery required, but not supplied

B = Belt Drive

★ CARB Compliance required for sale in California.

### OPTIONS

PART NO.	DESCRIPTION
8.916-172.0	Float Tank Kit (includes high pressure detergent kit), 1075BE & 1080BE models
8.916-173.0	Float Tank Kit (includes high pressure detergent kit) 965B model
8.931-259.0	Skid Rail Kit - adds 3.875" to height
8.931-260.0	Caster Kit - 2 casters / 2 wheels - adds 7.5" to height
8.931-261.0	Flat-free Tire Kit with Handle Bar - adds 10" to width, 6" to height
8.916-175.0	High Pressure Detergent Kit, 1075BE & 1080BE models (to be used with a remote water tank)
8.916-174.0	High Pressure Detergent Kit, 965B models (to be used with a remote water tank)
8.915-274.0	Stainless Steel Coil Wrap

▶ Field Installed    ▶ Factory Installed

- Gas/Diesel-Powered
- Oil-Fired
- Hotsy Belt-drive Pump
- Stainless Steel Coil Skin
- Electric Start

# 1200 SERIES

## BELT DRIVE

The 1200 Series delivers some serious on-site, hot water cleaning capability of up to 6 GPM and 4000 PSI. Rugged gasoline engines all have electric start. Five models come with a 2400W generator. The self-contained cleaning units are built to hold up under the toughest of conditions. All models are ETL safety certified and feature the Hotsy pump backed by a full 7-year limited warranty. All models come equipped with a 50' high-pressure hose, lance, nozzles and trigger gun.



MODEL	PART NO.	GPM	PSI	ENGINE MODEL	FUEL	CCs	BURNER	BTU/HR	PUMP MODEL	DIMENSIONS (LXWXH)	SHIP WT (LBS)
1260SS	1.110-533.0	4.7	3500	Briggs VAN 18	Gas	570	12V DC	414,318	HM4035R.2	45"x33"x52"	745
1260SSG*	1.110-535.0	4.7	3500	Briggs VAN 18	Gas	570	120V AC	414,318	HM4035R.2	45"x33"x52"	830
1270SS	1.110-557.0	4.5	4000	Honda GX630	Gas	688	12V DC	414,318	HX5843R.2	45"x33"x52"	855
1270SSG*	1.110-536.0	4.5	4000	Honda GX630	Gas	688	120V AC	414,318	HX5843R.2	45"x33"x52"	870
1270SSG-PR*	1.110-079.0	4.5	4000	Honda GX630	Gas	688	12V DC	414,318	HX5843R.2	45"x33"x52"	870
1280SS	1.110-558.0	5.1	3500	Honda GX630	Gas	688	12V DC	414,318	HX8043R.2	45"x33"x52"	760
1280SSG*	1.110-537.0	5.1	3500	Honda GX630	Gas	688	120V AC	414,318	HX8043R.2	45"x33"x52"	750
1290SS	1.110-538.0	5.6	3000	Honda GX630	Gas	688	12V DC	456,344	HX8043R.2	45"x33"x52"	744
1290SSG*	1.110-539.0	5.6	3000	Honda GX630	Gas	688	120V AC	456,344	HX8043R.2	45"x33"x52"	905
1291SS	1.110-075.0	8.0	3000	Honda GX690	Gas	688	12V DC	407,826	HX9536R	45"x33"x52"	760
1291SSG*	1.110-076.0	8.0	3000	Honda GX690	Gas	688	120V AC	407,826	HX9536R	45"x33"x52"	920
1265SSD	1.110-073.0	4.7	3500	Kubota Z602-E4B	Diesel	599	12V DC	414,318	HM4035	45"x33"x52"	795
1265SSD**	1.110-074.0	4.7	3500	Kubota Z602-E4B	Diesel	599	12V DC	414,318	HM4035	45"x33"x52"	795

\* Models include a 2400W generator

\*\*Models include stainless frame

12V battery is required for all models, but is not supplied

OPTIONS	
PART NO.	DESCRIPTION
8.903-025.0	Portagear Kit (all models)

▶ Field Installed    ▶ Factory Installed



1270SS (shown with optional Portagear Kit)

## HOT WATER PRESSURE WASHERS / DIESEL

- Diesel-Powered
- Diesel-Fired
- Hotsy Belt-drive Pump
- Stainless Steel Coil Skin
- Electric Start

# HSS & HSDDS SUPERSKID SERIES

## BELT DRIVE

The Super Skid HSS Series is by far, the largest and most powerful of Hotsy's hot water pressure washers. The Super Duty HSDDS models feature a Hawk pump with lower RPM for long lasting durability; there's literally nothing else on the market as robust, big & powerful. HSS models come standard with the reliable Hotsy triplex belt-driven high-pressure pump. Triple banded belt for more efficient power transmission. Models are powered by a 16 & 24 HP Kubota engines with electric start and all feature a 3/4-inch foil-backed insulated Schedule 80 heating coil with stainless steel skin and 5-year warranty. Two fuel tanks for longer operation, a high-efficiency Wayne burner and optional dual gun kit allows two users at one time. All models are ETL safety certified and feature the Hotsy pump backed by a full 7-year limited warranty. All models come equipped with a 50' high-pressure hose, lance, nozzles and trigger gun.



MODEL	PART NO.	GPM	PSI	ENGINE MODEL	CCs	BURNER	BTU/HR	PUMP MODEL	HOSE	DIMENSIONS (LXWXH)	SHIP WT (LBS)
HSS-503069E	1.110-604.0	5.0	3000	Kubota Z602-E4B	599	12V DC	465,000	HX5843R.2	50'-3/8"	73"x37"x64"	1305
HSS-653569E	1.110-605.0	6.5	3500	Kubota D1105-E4B	1123	12V DC	565,000	HX8043R.2	50'-3/8"	73"x37"x64"	1710
HSS-803069E	1.110-606.0	8.0	3000	Kubota D1105-E4B	1123	12V DC	635,000	HX9536.2	50'-1/2"	73"x37"x64"	1715
HSS-952569E	1.110-607.0	9.5	2500	Kubota D1105-E4B	1123	12V DC	780,000	HX1036R.2	50'-1/2"	73"x37"x64"	1715

All models are Electric Start. 12V battery is required for all models, but is not supplied.

### SUPER DUTY MODELS:

MODEL	PART NO.	GPM	PSI	ENGINE MODEL	CCs	BURNER	BTU/HR	PUMP MODEL	HOSE	DIMENSIONS (LXWXH)	SHIP WT (LBS)
HSDDS-503069E	1.110-616.0	5.0	3000	Kubota Z602-E4B	599	12V DC	465,000	HHP2750R	50'-3/8"	73"x37"x64"	1610
HSDDS-653569E	1.110-617.0	6.5	3500	Kubota D1105-E4B	1123	12V DC	565,000	HHP3650R	50'-3/8"	73"x37"x64"	2005
HSDDS-803069E	1.110-618.0	8.0	3000	Kubota D1105-E4B	1123	12V DC	635,000	HFR40FR	50'-1/2"	73"x37"x64"	2015
HSDDS-952569E	1.110-619.0	9.5	2500	Kubota D1105-E4B	1123	12V DC	780,000	HFR60FR	50'-1/2"	73"x37"x64"	2020

All models are Electric Start. 12V battery is required for all models, but is not supplied.

### OPTIONS

PART NO.	DESCRIPTION
8.923-164.0	Dual Gun Kit - includes necessary fittings, extra hose gun and wand
8.923-125.0	Steam Kit - includes necessary fittings and panel mount control valve
8.923-124.0	Float Tank Kit - includes float tank, necessary fittings and panel mount detergent metering valve

▶ Field Installed    ▶ Factory Installed



#### Pump size comparison:

The HFR and HHP pumps from Leuco used in the Super Duty models dwarf the standard HX.

- All-Electric
- Hotsy Belt-drive Pump
- Auto Start/Stop

# HWE SERIES ALL-ELECTRIC

## BELT DRIVE

The HWE Series is powered and heated by electricity, making it ideal for indoor use. It's a quiet machine with no fumes, making it ideal for food service and in-plant cleaning. Water is heated in a stainless steel heating coil, immersed in a tank of water solution, allowing for instant hot water once you pull the trigger. The heating elements do not come in contact with the pressurized water, which results in less maintenance and minimizes scale build up. All models are ETL safety certified and feature the Hotsy pump backed by a full 7-year limited warranty. All models come equipped with a 50' high-pressure hose, insulated variable pressure wand, nozzles and trigger gun.



MODEL	PART NO.	GPM	PSI	HP	MOTOR	AMPS	VOLT/PH	KvA HOUR	BTU/HR	PUMP MODEL	DIMENSIONS (LXWXH)	SHIP WT (LBS)
HWE-402009C	1.109-646.0	4.0	2000	6.2	Baldor	55	460/3	40.5	138,308	HM4030R.3	34"x25"x52"	620
HWE-403009C	1.109-647.0	3.5	3000	7.5	WEG	59	460/3	40.5	138,308	HM4030R.3	34"x25"x52"	640
HWE-402009F	1.109-958.0	3.5	2000	5	Baldor	46	575/3	40.5	138,308	HM4030R.3	34"x25"x52"	620

OPTIONS	
PART NO.	DESCRIPTION
8.903-042.0	Stainless Steel Washer Wrap 1700 Series* <span style="float: right;">▶</span>
8.925-520.0	Option, Time Delay Shut Down* <span style="float: right;">▶</span>
<span style="color: red;">▶</span> Field Installed <span style="color: blue;">▶</span> Factory Installed	



## HEATING MODULES

- Diesel
- Kerosene
- Home Heating Oil
- Natural Gas
- LP Gas (optional)

# 9400 SERIES

The 9400 Series heating modules offer the flexibility to “convert” a cold water pressure washer into a hot water unit. By attaching the heating module to a cold water pressure washer the pressurized water is now heated to produce all the benefits of hot water cleaning. The four models use fuel oil, diesel or natural gas to heat the water using Hotsy’s high-efficiency, vertical heating coil. All models are ETL safety certified and come equipped with a flow switch to control the burner.



Model 9462



Model 9452



MODEL	PART NO.	PSI (MAX)	GPM (MAX)	GPM (MIN)	VOLT/PH	BTU/HOUR	AMP	FUEL	DIMENSIONS (LXWXH)	SHIP WT (LBS)
9450	1.103-905.0	3200	10	6	115/1	700,000	8	Oil-Fired	32.5"x25"x50.5"	525
9452	1.103-906.0	3200	10	6	115/1	540,000	1	Natural-Gas-Fired	32.5"x25"x50.5"	500
9460	1.103-907.0	3200	10	6	115/1	920,000	8	Oil-Fired	40.5"x32"x65"	920
9462	1.103-908.0	3200	10	6	115/1	920,000	1	Natural-Gas-Fired	40.5"x32"x65"	935

### OPTIONS

PART NO.	DESCRIPTION
9.801-040.0	10" Natural Gas-Fired Draft Diverter for Model 9452
8.717-730.0	12" Natural Gas-Fired Draft Diverter for Model 9462
8.749-806.0	10" Power Dampener
8.753-171.0	12" Power Dampener
8.749-807.0	Power Dampener Wiring Harness
8.704-659.0	Hotsy Logo Label, 5" x 11"
8.903-076.0	Natural-Gas to LP Conversion for Model 9452
8.903-075.0	Natural-Gas to LP Conversion for Model 9462

▶ Field Installed    ▶ Factory Installed

- 200 Gallon Water Tank
- Single axle rated to 3500 pounds
- Swing Away Hinged Tongue
- Electric Brakes

# TRAIL BLAZER TRAILER

The Trail Blazer is Hotsy's affordable trailer solution that provides mobile cleaning anywhere. Axle assembly with leaf-spring suspension is rated at 3,500 lbs. The heavy duty-chassis features a swing-away hinge with swivel jack tongue assembly. The 200 gallon water tank features a float valve and 7-inch access port. 15-inch white spoke wheel assembly. Axle with electric brakes and break-away kit is the standard configuration.



Shown with 1080BE and optional accessories

**Select a trailer and add one of these pressure washer models:**

- 965B
- 1080BE
- 1075BE
- 1200 Series



MODEL	PART NO.	DIMENSIONS (LXWH)		WEIGHT (LBS)	SHIPPING WEIGHT (LBS)				
TRB-3500	1.103-818.0	136"x66"x52"		543	1043 (does not include pressure washer)				
GVWR	WATER TANK CAPACITY	GAWR	WHEELS	JACK	JACK CAPACITY	BALL COUPLER	SAFETY CHAINS	LIGHTING	
3500 lbs	200 gal	Single 3500 lbs	15" White Spoke Wheels ST205/75D15 Tires	Swivel Wheel w/ Caster Foot	1000 lbs	2"	Dual 5/16"	Recessed Lights are DOT Approved	

Does not qualify for free freight program. Call for freight quote.

OPTIONS	
PART NO.	DESCRIPTION
8.917-398.0	Brakes, Hydraulic
8.917-554.0	High Pressure Hose Reel
8.917-555.0	Low Pressure Hose Reel
8.917-556.0	Saddle Box Kit, set of two
8.917-557.0	Rock Guard Kit
8.917-583.0	Chrome Wheel Rims
8.924-493.0	2-5/16" Ball Hitch Coupler (adjustable height)
8.924-368.0	3" Lunette Eye Coupler
8.904-051.0	Battery Installed on Pressure Washer
8.917-290.0	Assembly Mounting (for 1200 Series)*
8.917-291.0	Assembly Mounting (for 965B, 1075BE, 1080BE Models)*

OPTIONS	
PART NO.	DESCRIPTION
8.917-559.0	Rock Guard Kit
8.917-558.0	Saddle Box Kit - single box only
8.917-560.0	Utility Rack Kit (150 lb. load capacity)

▶ Field Installed    ▶ Factory Installed

\*Required when purchasing a pressure washer and trailer package;  
NOT available for trailer only purchases.

## COLD WATER PRESSURE WASHERS / GAS ENGINE

- Honda, Vanguard or new Kohler diesel engine
- Small & large roll cage design
- Totally enclosed belt guard
- VRT3 unloader
- Flat-free tires for easy handling
- Hotsy Belt-drive Pump

# BD SERIES & HHD DIESEL

## BELT DRIVE

The BD Series is the most rugged cold water pressure washer on the market with its all-steel frame and cage, Hotsy belt-drive, triplex pump and cleaning power of up to 5000 PSI. Four gas models make up what is Hotsy's most durable cold water line-up ever. All models are ETL safety certified and feature the Hotsy pump backed by a full 7-year limited warranty. All models come equipped with a 50' high-pressure hose, lance, trigger gun, nozzles and chemical injector.



BD Series shown in large cage (4-wheel) version. Small cage 2-wheel version also available.



Diesel model uses the High Flow frame and comes as a skid, as shown



MODEL	PART NO.	GPM	PSI	ENGINE MODEL	CARB COMP.	CCs	PUMP MODEL	FRAME	NO. WHEELS	DIMENSIONS (LXWXH)	SHIP WT (LBS)
BD-373539	1.107-021.0	3.7	3500	Honda GX390	NO ★	389	HM4035R.3	Small Cage	2	42"x26"x30"	275
BD-404029	1.107-022.0	4.0	4000	Vanguard 16	YES	479	HX5843R.2	Large Cage	4	46"x30"x36"	360
BD-405039E*	1.107-023.0	4.0	5000	Honda GX630	YES	688	HX5450R	Large Cage	4	46"x30"x36"	417
BD-455039E*	1.107-024.0	4.5	5000	Honda GX690	YES	688	HX5450R	Large Cage	4	46"x30"x36"	430
HHD 3.4/30 D	1.107-382.0	3.4	3000	Kohler KD440	YES	442	HM3540R	Stainless Steel	4	50"x40"x50"	155

\*E = Electric Start (battery not included)

### OPTIONS

PART NO.	DESCRIPTION	
8.904-109.0	E-Zee Hose Reel Kit*100' (Small Cage)	▶
8.904-110.0	E-Zee Hose Reel Kit*100' (Large Cage)	▶
8.904-113.0	5000 PSI Hose Reel Kit,* (Large Cage)	▶
8.904-115.0	5000 PSI Dual Hose Reel Kit,*† (large cage)	▶
8.929-069.0	Flat-Free Cart Kit (HHD Model)	▶
8.750-478.0	100' Capacity Hose Reel (HHD Model)	▶

\*Includes hose reel and mounting hardware

†Includes garden hose reel and high-pressure hose reel

▶ Field Installed    ▶ Factory Installed

★ CARB compliance required for sale in California.

- Honda engines
- Totally enclosed belt guard
- Flat-free tires for easy handling
- Hotsy Belt-drive Pump

# BX SERIES

## BELT DRIVE

The BX Series is similarly rugged to the BD Series, but more compact. Powered by Honda engines, the BX series delivers cleaning power up to 3500 PSI and an all-steel frame protected by a durable powder coat finish. All models are ETL safety certified and feature the Hotsy pump backed by a full 7-year limited warranty. All models come equipped with a 50' high-pressure hose, lance, nozzles and trigger gun.



Shown with optional hose reel & mounting kit



MODEL	PART NO.	GPM	PSI	ENGINE MODEL	CARB	CCS	START	PUMP MODEL	FRAME	DIMENSIONS (LXWXH)	SHIP WT (LBS)
BX-282039	1.107-026.0	2.8	2000	Honda GX160	YES	163	Recoil	HB3030R	Small Chassis	37"x21"x24"	152
BX-373539	1.107-028.0	3.7	3500	Honda GX390	NO ★	389	Recoil	HM4035R.3	Large Chassis	45"x26"x24"	240
BX-373539	1.107-433.0	3.7	3500	Vanguard 400	YES	408	Recoil	HM4035R.3	Large Chassis	45"x26"x24"	240

### OPTIONS

PART NO.	DESCRIPTION
8.929-062.0	Detergent Injector (up to 3 GPM) ▶
8.756-797.0	Chemical Injector, Non-Adjustable 0.083 (2.1MM) ▶
8.723-636.0	Detergent nozzle ▶
8.904-103.0	EZ Hose Reel Kit 100' (incl. reel & mounting hardware) ▶

▶ Field Installed    ▶ Factory Installed

★ CARB compliance required for sale in California.



## COLD WATER PRESSURE WASHERS / GAS ENGINE

- Honda GX engines
- Steel frame
- 10" tubed pneumatic tires for easy handling
- Hotsy Direct-drive Pump

# DB SERIES

## DIRECT DRIVE

The DB Series is the most compact, affordable alternative in the cold water line featuring a direct-drive triplex pump. All models are powered by reliable Honda engines. Lightweight design and tubed pneumatic tires make for easy maneuvering. All models are ETL safety certified and feature the Hotsy pump backed by a full 7-year limited warranty. All models come equipped with a 50' high-pressure hose, lance, trigger gun, nozzles and chemical injector.



Shown with optional hose reel & mounting kit



MODEL	PART NO.	GPM	PSI	ENGINE MODEL	CARB COMP.	CCs	PUMP MODEL	HOSE (FT)	DIMENSIONS (LXWXH)	SHIP WT (LBS)
DB-232439	1.107-031.0	2.3	2400	Honda GX160	YES	163	HP2535G	50	35"x21"x24"	140
DB-252739	1.107-032.0	2.5	2700	Honda GX200	YES	196	HP2535G	50	35"x21"x24"	145
DB-303039	1.107-033.0	3.0	3000	Honda GX270	NO ★	270	HP3035G1	50	35"x21"x24"	175
DB-354039	1.107-222.0	3.5	4000	Honda GX390	NO ★	390	HS354093	50	35"x21"x24"	179
DB-383539	1.107-034.0	3.8	3500	Honda GX390	NO ★	390	HS4040G3	50	35"x21"x24"	179

### OPTIONS

#### PART NO. DESCRIPTION

8.904-105.0 EZ Hose Reel Kit 100' (includes reel & mounting hardware) ▶

▶ Field Installed    ▶ Factory Installed

★ CARB compliance required for sale in California.

- Honda GX and Vanguard engines
- VRT3 unloader with bypass loop
- Downstream chemical injection
- ETL certified to UL-1776 safety standards
- Modular design converts to skid
- Flat-free tires for easy handling
- Aluminum Frame

# HD SERIES

**DIRECT DRIVE**   **BELT DRIVE**

The HD Series are Hotsy's modular cold water pressure washers with corrosion resistant aluminum frame. Wheels can be removed allowing for easy trailer mounting. Models are available in belt or direct drive and powered by Honda GX and Vanguard engines. All models are ETL safety certified and feature the Hotsy pump backed by a full 7-year limited warranty. All models come equipped with a 50' high-pressure hose, lance, nozzles and trigger gun.



NEW  
VANGUARD  
ENGINE



MODEL	PART NO.	GPM	PSI	ENGINE MODEL	CARB COMP.	CCs	START	PUMP MODEL	DRIVE	HOSE (FT)	DIMENSIONS (LXWXH)	SHIP WT (LBS)
HD 3.0/27 G	9.807-711.0	3.0	2700	Honda GX200	YES	196	Recoil	LP3035	Direct	50	41"x22"x24"	112
HD 3.5/35 G	9.807-712.0	3.5	3500	Honda GX270	NO ★	270	Recoil	LP3535G.1	Direct	50	41"x22"x24"	130
HD 3.5/35 G	1.107-421.0	3.5	3500	Vanguard 300	YES	305	Recoil	LP3535G.1	Direct	50	41"x22"x24"	130
HD 4.0/40 G	9.807-713.0	4.0	4000	Honda GX390	NO ★	389	Recoil	LS4040G.3	Direct	50	43"x26"x27"	149
HD 4.0/40 G	1.107-429.0	4.0	4000	Vanguard 400	YES	408	Recoil	LS4040G.3	Direct	50	43"x26"x27"	149
HD 4.0/40 Ge*	9.807-714.0	4.0	4000	Honda GX390	NO ★	389	Electric	LS4040G.3	Direct	50	43"x26"x27"	158
HD 4.0/40 Ge*	1.107-435.0	4.0	4000	Vanguard 400	YES	408	Electric	LS4040G.3	Direct	50	43"x26"x27"	158
HD 3.0/27 GB	9.807-715.0	3.0	2700	Honda GX200	YES	196	Recoil	LP3035G	Belt	50	41"x22"x24"	123
HD 3.5/35 GB	9.807-716.0	3.5	3500	Honda GX270	NO ★	270	Recoil	LM3540R.3	Belt	50	41"x22"x24"	156
HD 3.5/35 GB	1.107-422.0	3.5	3500	Vanguard 300	YES	305	Recoil	LM3540R.3	Belt	50	41"x22"x24"	156
HD 4.0/40 GB	9.807-717.0	4.0	4000	Honda GX390	NO ★	389	Recoil	LM3840R.3	Belt	50	43"x26"x27"	160
HD 4.0/40 GB	1.107-430.0	4.0	4000	Vanguard 400	YES	408	Recoil	LM3840R.3	Belt	50	43"x26"x27"	160
HD 4.0/40 GeB*	9.807-718.0	4.0	4000	Honda GX390	NO ★	389	Electric	LM3840R.3	Belt	50	43"x26"x27"	196
HD 4.0/40 GeB*	1.107-434.0	4.0	4000	Vanguard 400	YES	408	Electric	LM3840R.3	Belt	50	43"x26"x27"	196
HD 5.0/30 GB	9.808-251.0	5.0	3000	Honda GX390	NO ★	389	Recoil	LM4035.R3	Belt	50	43"x26"x27"	160
HD 5.0/30 GB	1.107-446.0	5.0	3000	Vanguard 400	YES	408	Recoil	LM4035.R3	Belt	50	43"x26"x27"	160

\*Battery included on electric start models.

★ CARB compliance required for sale in California.

OPTIONS	
PART NO.	DESCRIPTION
9.807-750.0	37.5" Handle
9.807-751.0	Handle with Hose Reel (Mild Steel Anthracite Handle)
9.807-752.0	Hose Hook
9.807-753.0	Wand Holder

OPTIONS	
PART NO.	DESCRIPTION
8.929-509.0	Hose Reel Bracket Kit (Direct-Drive)
8.929-511.0	Hose Reel Bracket Kit (Belt-Drive)
9.807-754.0	Skid Mount Feet (set of 4)
	<i>Field Installed      Factory Installed</i>

## SKID OPTIONS

Dealer assembly required. Pressure washer sold separately.

The perfect accompaniment to Hotsy HD Series pressure washers – these mild steel skids offer two configurations: skid with a 50 gallon water tank and 100' hose reel OR skid with two 100' hose reels. The HD Skids fit within a standard UTV / ATV bed when ordering the direct drive models as depicted below. *NOTE: Belt drive models extend beyond the frame and are not recommended. Skid feet included.*



DESCRIPTION	PART NO.	FRAME MATERIAL	WATER TANK	HOSE REEL	COMPATIBLE PRESSURE WASHER (SOLD SEPARATELY)	DIMENSIONS (LXWXH)	SHIP WT (LBS)
One 100' Hose Reel & 50 gallon Water Tank	9.807-835.0	Mild Steel	50 gallon	1	HD 3.0/27 G 9.807-711.0 HD 3.5/35 G 9.807-712.0 HD 4.0/40 G 9.807-713.0	40"x48"x35"	180 (excluding pressure washer)
Two 100' Hose Reels	9.807-840.0	Mild Steel	Not Included	2	HD 3.0/27 G 9.807-711.0 HD 3.5/35 G 9.807-712.0 HD 4.0/40 G 9.807-713.0	40"x48"x35"	172 (excluding pressure washer)



- Reliable Kärcher engine with an extended 4-year warranty for a limited time
- Direct and Belt drive models
- Durable VRT3 unloader with bypass loop diverts water flow when trigger gun is not activated
- Aluminum frame - modular design - converts easily from cart to skid

# TETON SERIES

## DIRECT DRIVE

Corrosion-resistant and light-weight, Kärcher's direct drive, Teton Series aluminum pressure washers can be utilized as a cart or a skid for maximum cleaning versatility and durability. These reliable Kärcher powered pressure washers offer a 4-year engine warranty for a limited time, bypass loop for additional pump protection, 7-year pump warranty and flat-free tires.



MODEL	PART NO.	GPM	PSI	DRIVE	CC	ENGINE	CARB COMP.	PUMP	SHIP WEIGHT (LBS)	SHIP DIMENSIONS (L X W X H) INCHES
HD 3.0/27 G Teton	1.107-398.0	3.0	2700	Direct	212	Kärcher	YES	Crankcase	112	45 x 28 x 29
HD 3.5/35 G Teton	1.107-440.0	3.5	3500	Direct	212	Kärcher	YES	Crankcase	112	45 x 28 x 29
HD 4.0/40 G Teton	1.107-399.0	4.0	4000	Direct	420	Kärcher	YES	Crankcase	130	45 x 28 x 29
HD 4.0/40 Ge Teton*	1.107-400.0	4.0	4000	Direct	420	Kärcher	YES	Crankcase	158	45 x 28 x 29

\*Electric start available on select models.

### ACCESSORIES

PART NO.	DESCRIPTION
■ 8.750-247.0	Trigger Gun, model M407
■ 8.925-129.0	Hose, 50' x 3/8", 1w, 4,000 PSI SWXSO
■ 8.783-039.0	Lance 30" Zinc plated, handle & coupler (for HD 3.0/27 G Classic)
■ 8.783-040.0	Lance 44" Zinc plated, handle & coupler (for HD 4.0/40 G Classic and HD 4.0/40 Ge Classic)
■ 9.802-216.0	Injector, Chem, NON ADJ, 0.083
□ 8.712-429.0	Nozzle
□ 8.925-229.0	Legacy, 100' x 3/8" ID, 6000 PSI, 2-wire, smooth cover, black high pressure hose
□ 8.753-572.0	A+ Surface Cleaner SC21
□ 8.753-573.0	A+ Surface Cleaner SC24
□ 9.302-243.0	Legacy Turbo Nozzle, 4.0, 4350 PSI
□ 8.710-620.0	Legacy Superlite stainless steel wand, 72" - 56.0 oz
□ 9.807-754.0	Skid mount feet
□ 9.807-750.0	37.5" long handle
□ 9.807-753.0	Lance holder
□ 9.807-752.0	Hose storage hook
□ 9.807-751.0	Handle with hose reel (mild steel anthracite handle)

- Included
- Optional



## COLD WATER PRESSURE WASHERS / ELECTRIC

- Hotsy Belt-drive Pump
- 12' cord length
- Totally enclosed belt guard
- Flat-free tires for easy handling

# BDE SERIES

## BELT DRIVE

The BDE Series is the electric equivalent of the BD Series. Hotsy belt-drive, triplex pump and cleaning power of 5000 PSI. All models are ETL safety certified and feature the Hotsy pump backed by a full 7-year limited warranty. All models come equipped with a 50' high-pressure hose, lance, trigger gun, nozzles and chemical injector.



MODEL	PART NO.	GPM	PSI	HP	MOTOR RPM	VOLT/ PH	AMPS	PUMP MODEL	PUMP RPM	HOSE (FT)	DIMENSIONS (LXWXH)	SHIP WT (LBS)
BDE-505009B	1.107-085.0	5.0	5000	20	1765	230/3	48	HX5450R	1650	50	46"x30"x36"	524
BDE-505009C	1.107-086.0	5.0	5000	20	1765	460/3	26	HX5450R	1650	50	46"x30"x36"	524

### OPTIONS

PART NO.	DESCRIPTION	
8.904-110.0	E-Zee Hose Reel Kit*100' (large cage)	▶
8.904-113.0	5000 PSI Hose Reel Kit,* (large cage)	▶
8.904-115.0	5000 PSI Dual Hose Reel Kit,*† (large cage)	▶

\*Includes hose reel and mounting hardware

†Includes garden hose reel and high-pressure hose reel

▶ Field Installed    ▶ Factory Installed

- Electric motor, 2-10 HP
- Downstream detergent injector
- Hotsy Belt-drive Pump
- Insulated SS variable pressure wand
- Option-ready for Time Delay Shutdown or Auto Start/Stop

# 1700 SERIES

## BELT DRIVE

The 1700 Series offers the most reliable, stationary, electric-powered, cold water pressure washer. All models are ETL safety certified and feature the Hotsy pump backed by a full 7-year limited warranty. All models come equipped with a 50' high-pressure hose, insulated variable pressure wand, trigger gun, nozzles and chemical injector.



Shown with optional stainless steel cabinet



Model 1710 shown with optional wheel kit & chemical rack (PN 9.801-031.0). Note: this is not the short stand.

1700 Series shown with optional hose reel kit, (PN 8.903-039.0), Tall Floor Stand (PN 9.801-034.0), caster wheel kit (PN 9.801-035.0) and stainless steel base and cover (PN 8.903-042.0).



MODEL	PART NO.	GPM	PSI	HP	VOLT/PH	AMPS	PUMP MODEL	PORTABILITY	DIMENSIONS (LXWXH)	SHIP WT (LBS)
1710	1.106-511.0	2.8	1000	2	120/1	20	HB3030R	Optional	31"x21"x16"	200
1720	1.106-512.0	3.9	2000	6	230/1	28	HM4030R.3	Optional	31"x21"x16"	275
1722	1.106-513.0	3.9	2000	6	208/1	30	HM4030R.3	Optional	31"x21"x16"	250
1723	1.106-514.0	3.9	2000	6	208/3	16	HM4030R.3	Optional	31"x21"x16"	250
1724	1.106-515.0	3.9	2000	6	230/3	16.8	HM4030R.3	Optional	31"x21"x16"	250
1725	1.106-516.0	3.9	2000	6	460/3	8	HM4030R.3	Optional	31"x21"x16"	250
1726	1.106-590.0	3.9	2000	7.5	575/3	6.6	HM4030R.3	Optional	31"x21"x16"	275
1743	1.106-529.0	4.8	3000	10	208/3	31.3	HM4035R.3	Optional	31"x21"x16"	302
1744	1.106-530.0	4.8	3000	10	230/3	26.8	HM4035R.3	Optional	31"x21"x16"	300
1745	1.106-531.0	4.8	3000	10	460/3	15	HM4035R.3	Optional	31"x21"x16"	315
1746	1.106-591.0	4.8	3000	10	575/3	9.6	HM4035R.3	Optional	31"x21"x16"	290
1753	1.106-534.0	5.6	2500	10	208/3	31.3	HX9536R.2	Optional	31"x21"x16"	320
1754	1.106-535.0	5.6	2500	10	230/3	26.8	HX9536R.2	Optional	31"x21"x16"	310
1755	1.106-536.0	5.6	2500	10	460/3	13.5	HX9536R.2	Optional	31"x21"x16"	310
1756	1.106-592.0	5.6	2500	10	575/3	10.3	HX9536R.2	Optional	31"x21"x16"	310

OPTIONS	
PART NO.	DESCRIPTION
9.801-031.0	Kit, 1700 Wheel w/Chemical Rack (black) ▶
8.904-527.0	Kit, 1700 Wheel w/Chemical Rack (stainless steel) ▶
9.801-033.0	Kit, 1700 Wall Mount ▶
9.801-034.0	Kit, 1700 Floor Stand, Tall (20 3/4"W x 29"D x 36"H) ▶
9.801-035.0	Kit, Caster Wheels for 1700 Floor Stand ▶
8.903-039.0	Kit, Hose Reel w/Bracket for 1700 Stand & Wall Mount Kits ▶
8.903-040.0	Kit, 1700 Floor Stand, Short (20 3/4"W x 29"D x 24"H) ▶
8.903-043.0	Kit, 1700 Wall Mount, Stainless Steel ▶
8.903-617.0	Kit, 1700 Floor Stand, Tall, Stainless Steel ▶
8.903-521.0	Kit, Hose Reel for Wheel Kit, 100 ft. (excludes hose) ▶

▶ Field Installed    ▶ Factory Installed

OPTIONS	
PART NO.	DESCRIPTION
8.903-041.0	Time Delay Shut Down 3ph (1723, 1724, 1725, 1726, 1743, 1744, 1745, 1746) ▶
8.903-044.0	Time Delay Shut Down 3ph (1753, 1754, 1755, 1756) ▶
8.903-045.0	Time Delay Shut Down 120v 1ph (1710) ▶
8.929-374.0	Time Delay Shutdown 208/230v 1ph (1720, 1722) ▶
8.903-047.0	Auto Start/Stop 3ph (1723, 1724, 1725, 1726, 1743, 1744, 1745, 1746) ▶
8.903-048.0	Auto Start/Stop 3ph (1753, 1754, 1755, 1756) ▶
8.929-376.0	Auto Start/Stop 120v 1ph (1710) ▶
8.929-377.0	Auto Start/Stop 208/230v 1ph (1720, 1722) ▶
8.923-421.0	Stainless Steel Base & Cover for Model 1710 ▶
8.903-042.0	Stainless Steel Base & Cover for Models 172x, 174x, 175x ▶

\*Time Delay Shutdown and Auto Start/Stop cannot be combined on the same machine

## COLD WATER PRESSURE WASHERS / ELECTRIC

- Aluminum frame
- Converts easily to skid style frame
- Flat-free tires for easy handling
- Hotsy Direct-drive Pump

# HD SERIES ELECTRIC CART

## DIRECT DRIVE

The HD Series electric carts are corrosion-resistant aluminum cold water pressure washers that easily convert from a cart to a skid for maximum cleaning versatility. Low profile handle and compact footprint. All models are ETL safety certified and feature the Hotsy pump backed by a full 7-year limited warranty. All models come equipped with a 50' high-pressure hose, lance, trigger gun, nozzles and chemical injector.



MODEL	PART NO.	GPM	PSI	HP	VOLT/PH	MOTOR RPM	AMPS	PUMP MODEL	HOSE (FT)	DIMENSIONS (LXWXH)	SHIP WT (LBS)
HD 1.9/13 Ed	9.801-798.0	1.9	1300	2	120/1	1725	20	LFP2030S	50	35"x21"x24"	196
HD 2.0/10 Ed	9.801-797.0	2.0	1000	1.5	120/1	1725	15	LFP2030S	50	35"x21"x24"	212
HD 3.0/10 Ed	9.801-799.0	3.0	1000	2	120/1	1725	20	LF2830S	50	35"x21"x24"	219
HD 3.5/20 Ea	9.801-800.0	3.5	2000	5	230/1	3450	22	LF3530F	50	35"x21"x24"	220

### OPTIONS

PART NO.	DESCRIPTION	
9.807-754.0	Skid Feet (set of 4)	▶
9.807-750.0	37.5" Long Handle	▶
9.807-751.0	Handle with Hose Reel (Mild Steel Anthracite Handle)	▶
9.807-752.0	Hose Storage Hook	▶
9.807-753.0	Wand Holder	▶

▶ Field Installed    ▶ Factory Installed

- Hotsy Direct-drive Pump
- 25' & 50' hose
- Convenient carrying handle
- Remote switch with 10' cord (ET-201409DX2 only)
- Standard Auto Start/Stop (ET-201409DX2)

# ET SERIES HANDHELD

## DIRECT DRIVE

The ET Series is the handheld model of the electric-powered line, delivering cleaning capability up to 1400 PSI. All models are ETL safety certified and feature the Hotsy pump backed by a full 7-year limited warranty. All models come equipped with a 50' high-pressure hose, lance, nozzles and trigger gun.



Note: Detergent injector sold separately



MODEL	PART NO.	GPM	PSI	HP	VOLT/PH	PUMP MODEL	HOSE (FT)	DIMENSIONS (LXWXH)	SHIP WT (LBS)
ET-301109D	1.106-107.0	3.0	1000	2.0	115/1	HF2830S	50	20"x19"x17"	121
ET-201409DX2	1.107-089.0	1.8	1400	2.0	115/1	HFP2030S	25	20"x19"x17"	123

### OPTIONS

PART NO.	DESCRIPTION
8.920-952.0	Wall Mount Bracket
8.929-062.0	Detergent Injector (up to 3 GPM)

▶ Field Installed    ▶ Factory Installed

- Heater add-on
- 3000 PSI
- Diesel, kerosene, #1 heating oil
- 3/8" QC inlet / outlet
- Efficient vertical combustion
- 5-gallon polyethylene fuel tank
- 36" ground fault interrupter plug
- Thermostat temperature control

# HOT BOX OIL-FIRED

Add hot water cleaning economically. Portable water heater add-on for existing cold water pressure washers. Quick connect to cold water washer, supply fuel and power to Hot Box for hot water cleaning applications — USE ONLY WHEN NEEDED and keep the convenience of the portable cold water washer.



MODEL	PART NO.	GPM	PSI	VOLT/PH	DIMENSIONS (LXWXH)
HOT BOX	1.103-910.0	Up to 5	Up to 3,000	120/1	27"x37"x39"



## COLD WATER PRESSURE WASHERS / GAS ENGINE

- Smart Relay Control provides control over run time, auto start/stop and shut down functionality
- Remote-ready
- Hotsy Belt-drive Pump

# CWC SERIES

## BELT DRIVE

The CWC Series is a completely self-contained, stationary, electric-powered, cold water washer with programmable smart control, upstream detergent injector and ETL safety certification. Remote ready for wash bays. All models are ETL safety certified and feature the Hotsy pump backed by a full 7-year limited warranty. All models come equipped with a 50' high-pressure hose, lance, nozzles and trigger gun.



MODEL	PART NO.	GPM	PSI	HP	MOTOR RPM	VOLT/PH	AMP	PUMP MODEL	HOSE (FT)	SHIP WT (LBS)
CWC-53	1.106-572.0	4.0	3000	7.5	1725	230/1	36	HM4030R.3	50	340
CWC-54	1.106-573.0	4.0	3000	7.5	1725	230/3	23	HM4030R.3	50	340
CWC-55	1.106-574.0	4.0	3000	7.5	1725	460/3	11	HM4030R.3	50	340
CWC-56	1.106-575.0	4.0	3000	7.5	1770	575/3	9	HM4030R.3	50	340
CWC-63	1.106-576.0	5.0	2000	7.5	1725	230/1	36	HM4035R.3	50	340
CWC-64	1.106-577.0	5.0	2000	7.5	1725	230/3	18	HM4035R.3	50	340
CWC-65	1.106-578.0	5.0	2000	7.5	1725	460/3	9	HM4035R.3	50	340
CWC-66	1.106-579.0	5.0	2000	7.5	1770	575/3	8	HM4035R.3	50	340

### OPTIONS

PART NO.	DESCRIPTION
8.916-989.0	Remote Station (image 1 below) <span style="float: right;">▶</span>
8.924-814.0	R-Con Wireless Remote Kit (1 remotes/1 receiver) (image 2 below) <span style="float: right;">▶</span>
8.925-072.0	R-Con Wireless Remote Kit (2 remotes/1 receiver) <span style="float: right;">▶</span>

▶ Field Installed    ▶ Factory Installed

### OPTIONS

PART NO.	DESCRIPTION
8.924-878.0	Wall Mount Remote Bracket for R-Con (image 3 below) <span style="float: right;">▶</span>
8.756-329.0*	Replacement Remote (transmitter only) <span style="float: right;">▶</span>
8.916-988.0	Soap Solenoid and Switch <span style="float: right;">▶</span>

\* **Please Note: R-Con Wireless Remote** comes from vendor, is custom made to order and is not universal. When ordering, please contact customer service to supply the serial number off the transmitter you have along with the channel number, so we can pass along that information to the vendor.



- 3 stage vacuum motor delivers 100 CFM 100" sealed lift vacuum
- Simple curbside controls for easy use
- Rated for water up to 120°F and compatible with surface cleaners and hot water machines
- Bolt-on mounting system configured on the base to mount to a trailer for portability from site to site or optional caster wheel kit
- Small footprint allows the unit to be mounted where limited space is available
- Drain port and filter basket work together to keep sludge from clogging

# RC SERIES WATER RECOVERY

Stop wash water from flowing down a drain or away from your area by collecting the wastewater from pressure washing. As EPA laws become more prevalent and strive to conserve water quality, contract cleaners and construction sites will need to recover their wash water and runoff. Eliminate the problem with the RC Series that is capable of recovering and transferring up to 30 GPM of water and transferring to a holding tank. Its small footprint allows the RC Series to be mounted on a trailer. Be fully in control of water flow with the optional water dikes and drain covers to stop water from flowing down a drain or away from your site. Comes standard with a 50' vacuum hose and scupper head.



Reliable 120V Transfer Pump capable of transferring 30 GPM of water to the holding tank



Shown with optional caster wheel kit



MODEL	PART NO.	ELECTRICAL	AMPS	RECOVERY	TANK (GAL)	VACUUM MOTOR	DIMENSIONS (LXWXH)	SHIP WT (LBS)
RC-30E	1.103-514.0	120V	15	30 GPM	27	3 Stage 100 CFM 100" sealed lift	24"x27"x59"	127

**OPTIONS**

PART NO.	DESCRIPTION
8.751-299.0	Mosmatic Surface Cleaner with Vac Port <span style="float: right;">▶</span>
8.928-887.0	Caster Wheel Kit <span style="float: right;">▶</span>
8.925-858.0	Discharge Hose Kit <span style="float: right;">▶</span>
8.618-451.0	Vacuum Hose <span style="float: right;">▶</span>
8.928-850.0	Scupper Head <span style="float: right;">▶</span>

**DRAIN COVERS & WATER DIKES**

PART NO.	DESCRIPTION
8.751-135.0	Drain Cover, 36" x 36", 30oz PVC <span style="float: right;">▶</span>
8.751-136.0	Drain Cover, 48" x 48", 30oz PVC <span style="float: right;">▶</span>
8.751-137.0	Drain Cover, 48" x 48", Urethane <span style="float: right;">▶</span>
8.751-138.0	Water Dike, 10', 22oz PVC <span style="float: right;">▶</span>
8.751-139.0	Water Dike, 10', 40oz Urethane <span style="float: right;">▶</span>
8.751-140.0	Water Dike, 20', 22oz PVC <span style="float: right;">▶</span>
8.751-141.0	Water Dike, 20', 40oz Urethane <span style="float: right;">▶</span>

▶ Field Installed    ▶ Factory Installed

# HOTSY'S DIRTY DOZEN DETERGENTS

For soap recommendations, start with these 12 category leaders



## #1 BREAKTHROUGH!

### Hotsy's best all-purpose detergent

Highly concentrated with dilution ratio of 150 to 1. Whether removing grease or cleaning a finely painted automobile, Breakthrough! is the best all around "go to" detergent. Breakthrough's high foaming action attacks dead oxidized paint and can be used in hard and cold water applications.

## #2 TRANSPORT VEHICLE WASH

### Hotsy's most economical detergent for vehicles

If it has wheels, Transport is the detergent of choice. Autos, buses, motor homes, mobile homes, tractor trailers are just a few applications for this economical liquid detergent. Great when used as a pre-spray for engine compartment cleaning and safe on all painted surfaces, stainless steel, aluminum and glass.

## #3 RIPPER 1

### Hotsy's best heavy-duty degreaser

Ripper 1 is specially formulated for degreasing heavy equipment and hard to remove road film on tractor trailers, end loaders, excavators and back hoes, yet still safe on painted surfaces. Non-caustic and user-friendly.

## #4 HOTSY BROWN

### Hotsy's best detergent for oil field cleaning

A degreasing detergent specially formulated for the oil field that also works great on oil soaked or stained surfaces such as, frames and equipment. A non-Butyl based product that works good in cold water, Hotsy Brown is a caustic based product and should not be used on fine painted surfaces or magnesium, galvanized or aluminum.

## #5 ADVANCED FORMULA ALUMINUM BRIGHTENER

### Hotsy's answer to aluminum cleaning

This highly concentrated acid with dilution ratios up to 20 to 1, attacks oxidized aluminum leaving a "like new" look to the surface after the initial application. Not to be used on new aluminum or aluminum that is not oxidized.

## #6 VERDE ALL-PURPOSE

### Environmentally-friendly general purpose cleaner

A unique blend of environmentally preferred chemicals that provide great cleaning capabilities in all water conditions and all water temperatures. Superior foaming and fast-rinsing provide great results while saving money and the environment.

## #7 SALT LICK

### Hotsy's answer to removing salt and de-icing solutions

Salt Lick is formulated to remove salt, calcium chloride and de-icing solution used on winter roads by breaking down the crystalline structure of ice melt products and prevents them from re-crystallizing so they can be washed away. Salt Lick is a dual-purpose concentrated detergent attacking heavy soils and road film.

## #8 CARBOCHLOR

### Hotsy's #1 choice for cleaning food preparation areas

A special emulsifying formula with high powered bleach for food processing plants. Excellent on tough odors, stains, dirt, oils and fats left behind on equipment, floors, and walls. NSF recognized for use in Federally Inspected food plants, non-food compounds A1

## #9 CON-B-GONE

### Removes green concrete from trucks & tools

A fast acting acidic product that when applied to ready mix trucks, forms and tools softens dried concrete splatter allowing it to be rinsed away with a hot or cold water pressure washer. Con-B-Gone's foaming formula makes application over large areas quick and easy. A Hotsy Foamer increases dwell time and maximizes end results!

## #10 TUBMATE GEN. PURPOSE

### Hotsy's heavy-duty automatic parts washer detergent

A phosphate-free super-concentrated liquid. Works great with automatic detergent injectors; can be automatically metered into aqueous parts washers. Quick oil release and solvent free. Heavy duty rust and corrosion inhibitor package protects against flash rusting; defoamers reduce foam in your aqueous parts washer.

## #11 FAT CAP

### Hotsy's easy-to-use liquid graffiti remover

The #1 alternative to sand blasting or painting over unsightly graffiti. Designed for use on exterior brick, masonry and concrete surfaces. Deep-penetrating and fast-acting for effective and thorough loosening of spray paint graffiti and easy removal of graffiti from the surface being treated.

## #12 CITRUS CLEAN

### "Beefs" up the cleaning action of any Hotsy soap

This citrus-based detergent additive increases any detergent's cleaning and degreasing power and is a great degreaser in its own right, plus it also enhances rinsing. Contains d-limonene which is a great "natural" degreaser.

**PLEASE NOTE:** Hotsy detergents should be used following the instructions printed on the product label and best safety practices. Some Hotsy Detergents cannot ship UPS. For more information please contact your local Hotsy Distributor.

## ALL-PURPOSE



✓ Kosher Approved

### BREAKTHROUGH! Hotsy's #1 Recommended All-Purpose Detergent

This highly concentrated detergent is extremely popular and effective for tackling crude oil and caked-on buildup of fifth-wheel grease... yet it's gentle enough for fine finishes on cars and to use for general cleaning purposes. Helps restore all types of oxidized paint surfaces. Excellent in cold water.

PART NO.	DESCRIPTION	FORM	SHIP WT (LBS)
8.905-136.0	5 Gallons	Liquid	46
8.905-137.0	55 Gallons	Liquid	504
9.846-023.0	Super Concentrate Kit*	Powder/Liquid	102
9.846-024.0	Super Concentrate Kit, 9 Pak*	Powder/Liquid	900
9.846-082.0	5 Gal. Product Label, Pkg. of 50		

**SPECIFICATIONS:** ■ pH: 12.92 ■ Foaming Action: High ■ Reaction in Hard Water (TDS): Best ■ Dilution Ratio: 1:150 ■ Color: Red/Orange ■ Scent: Solvent ■ Hotsy Continuous Clean Additives **RECOMMENDED APPLICATIONS AND USES:** Vehicles / Trucks, Painted / Unpainted Surfaces, Grease / Oils, Drilling Rigs, Degreasing, Road Film, Farm Equipment, Asphalt / Tar, Diesel Smoke, Food Industry, Baked-on Carbon, Floors / Walls, Construction Equipment, Stainless Steel, Oxidized Paint, Aluminum

## BLUE THUNDER

✓ Kosher Approved

A popular vehicle cleaner for removing exhaust deposits, road film and bug residue. Excellent for older vehicles with faded finishes; helps restore oxidized paint surfaces of all types. Great for housewashing. Works well in cold water.

PART NO.	DESCRIPTION	FORM	SHIP WT (LBS)
8.905-442.0	5 Gallons	Liquid	46
8.905-445.0	Super Concentrate*	Powder	49
8.905-446.0	9 Pak Super-Concentrate*	Powder	442
8.698-246.0	275-Gallon Tote	Liquid	2472
8.765-850.0	5 Gal. Product Label, Pkg. of 50		

**SPECIFICATIONS:** ■ pH: 12.46 ■ Foaming Action: Low ■ Reaction in Hard Water (TDS): Good ■ Dilution Ratio: 1:100 to 1:120 ■ Color: Clear Light Blue ■ Scent: Musty ■ Hotsy Continuous Clean Additives **RECOMMENDED APPLICATIONS AND USES:** Farm Machinery, Road Film, Diesel Smoke, Restaurants, Stainless Steel, Aluminum, Log Cabins / Houses, Floors / Walls, Grease / Oils, Decks / Fences / Siding, Exhaust Trails, General Cleaning

## PRODUCT 31

✓ Kosher Approved

Here's an all-purpose vehicle cleaner for a wide range of applications. Use it on over-the-road tractors and trailers, truck fleets, and cars. Powerful yet gentle cleaners attack road film and dirt while protecting painted surfaces. Helps restore all types of oxidized paint surfaces.

PART NO.	DESCRIPTION	FORM	SHIP WT (LBS)
9.846-057.0	Super Concentrate Kit*	Powder/Liquid	59
9.846-081.0	5 Gal. Product Label, Pkg. of 50		

**SPECIFICATIONS:** ■ pH: 12.32 ■ Foaming Action: Medium ■ Reaction in Hard Water (TDS): Good ■ Dilution Ratio: 1:150 ■ Color: Clear Green ■ Scent: Floral/Solvent ■ Hotsy Continuous Clean Additives **RECOMMENDED APPLICATIONS AND USES:** Farm Equipment, Stainless Steel, Aluminum, Oxidized Paint, Agriculture, Whitewalls, General Cleaning, Degreasing, Transportation, Painted / Unpainted Surfaces, Fiberglass, Engine Cleaning, Food Industry, Vinyl Tops, Road Film, Dirt

## SUPER X

✓ Kosher Approved

This concentrated powder is popular in the agriculture, construction, transportation and food industries. Safe on all surfaces, it's easy to use, low foaming and free rinsing. Mix Instructions: Dissolve 8 oz. (1 cup) with 1 gallon warm (90°) water. Regulate amount desired with detergent metering valve.

PART NO.	DESCRIPTION	FORM	SHIP WT (LBS)
8.904-673.0	50 lb Drum	Powder	53
8.904-674.0	100 lb Drum	Powder	104
8.904-675.0	450 lb Drum	Powder	469
9.846-061.0	5 Gal. Product Label, Pkg. of 50		

**SPECIFICATIONS:** ■ pH: 10.98@1% ■ Foaming Action: Low ■ Reaction in Hard Water (TDS): Best ■ Dilution Ratio: See Above ■ Color: Red ■ Scent: Slight Detergent ■ Free Rinsing **RECOMMENDED APPLICATIONS AND USES:** Food Industry, Painted / Unpainted Surfaces, Aluminum, Diesel Smoke, Farming, Road Film, General Cleaning, Fiberglass, Veterinarian Services, Stainless Steel, Kennels, Dirt, General Livestock, Grease / Oils, Floors / Walls, Carbon

\* Entire contents of each additive drum should be used at one time, do not attempt to make partial batches.

**SUPER XL**

✓ Kosher Approved

Low foaming detergent for reduced rinse time. A highly efficient truck wash detergent designed to be low foaming and very free rinsing. Super XL cleans without the bubbles and foam to drastically reduce rinse time and is a favorite of contract cleaners and truck wash facilities.

PART NO.	DESCRIPTION	FORM	SHIP WT (LBS)
8.904-725.0	5 Gallons	Liquid	46
8.904-728.0	55 Gallons	Liquid	494
8.904-677.0	Super Concentrate Kit*	Powder	48
8.904-681.0	Super Concentrate Kit, 8 Pak*	Powder	391
9.846-062.0	5 Gal. Product Label, Pkg. of 50		

**SPECIFICATIONS:** ■ pH: 11.96 ■ Foaming Action: Low ■ Reaction in Hard Water (TDS): Best ■ Dilution Ratio: 1:128 ■ Color: Red ■ Scent: Detergent  
 ■ Free Rinsing **RECOMMENDED APPLICATIONS AND USES:** Vehicles / Trucks, Construction, Vehicles, Engines, Road Film, Grease / Oils, Agriculture, Food Processing, Aluminum, Diesel Smoke, General Cleaning, Dairy Farms, Industrial Equipment, Stainless Steel, Carbon, Veterinarians, Farm Equipment, Mold / Mildew, Degreasing Surfaces, Painted / Unpainted, Floors / Walls

**VEHICLE WASH**



**TRANSPORT VEHICLE WASH Hotsy's #1 Recommended Vehicle Wash**

✓ Kosher Approved

Economical liquid detergent cleans stainless steel, aluminum, glass and painted surfaces such as cars, trucks, buses, RV's, trailers, mobile homes, tractors, etc. Use as a pre-spray for cleaning engines, whitewall tires, vinyl and metal tops.

PART NO.	DESCRIPTION	FORM	SHIP WT (LBS)
8.904-732.0	5 Gallons	Liquid	47
8.904-733.0	55 Gallons	Liquid	506
9.846-027.0	Super Concentrate*	Powder/Liquid	53
9.846-092.0	Super Concentrate, 9 Pak*	Powder/Liquid	523
9.846-089.0	5 Gal. Product Label, Pkg. of 50		

**SPECIFICATIONS:** ■ pH: 12.7 ■ Foaming Action: Medium ■ Reaction in Hard Water (TDS): Good ■ Dilution Ratio: 1:100 ■ Color: Red ■ Scent: Musty Solvent  
 ■ Hotsy Continuous Clean Additives **RECOMMENDED APPLICATIONS AND USES:** Automotive / Trucking / Vehicles, Stainless Steel, Aluminum, Glass, Engines, Whitewalls, Vinyl and Metal Tops, Salts, Fiberglass, Painted Surfaces, Clay, Degreasing

**CARBON-ATE**

✓ Kosher Approved

Especially formulated to clean engine compartments and hard to clean vehicles, road film, white wall tires and carbon (diesel smoke and exhaust). Works great on polished aluminum.

PART NO.	DESCRIPTION	FORM	SHIP WT (LBS)
8.904-896.0	5 Gallons	Liquid	47
8.904-898.0	55 Gallons	Liquid	506
9.846-000.0	Super Concentrate Kit*	Powder/Liquid	94
9.846-001.0	Super Concentrate Kit, 9 Pak*	Powder/Liquid	873
9.846-063.0	5 Gal. Product Label, Pkg. of 50		

**SPECIFICATIONS:** ■ pH: 12.48 ■ Foaming Action: High ■ Reaction in Hard Water (TDS): Best ■ Dilution Ratio: 1:150 ■ Color: Green ■ Scent: Slight Detergent  
 ■ Hotsy Continuous Clean Additives **RECOMMENDED APPLICATIONS AND USES:** Vehicles, Painted / Unpainted Surfaces, Road Film, Grease / Oil, Baked-on Carbon, Fish / Animal Oils, Bug Residue, Fiberglass, Mold / Mildew, Whitewalls, Aluminum, Stainless Steel

**ENVY SUPER CONCENTRATE**

✓ Kosher Approved

A vehicle wash detergent that works well in all water conditions and temperatures. Ultra concentrated, hard water formula, high-foaming, easy rinsing, flows in colder temperatures.

PART NO.	DESCRIPTION	FORM	SHIP WT (LBS)
8.698-077.0	Qty 4, 1 Gallon Containers	Liquid	35
8.698-078.0	5 Gallons	Liquid	44

**SPECIFICATIONS:** ■ pH: 9.74 ■ Foaming Action: High ■ Reaction in Hard Water (TDS): Good ■ Dilution Ratio: 1:700 ■ Color: Dark Green ■ Scent: Floral  
 ■ Hotsy Continuous Clean Additives **RECOMMENDED APPLICATIONS AND USES:** Trucks, Automobiles, Automatic Car Washes

\* Entire contents of each additive drum should be used at one time, do not attempt to make partial batches.



**FLEET WASH**

✓ Kosher Approved

Extremely effective for cleaning stainless steel, aluminum, glass and painted surfaces on cars, trucks, RV's, buses, trailers, mobile homes, tractors etc. Perfect pre-spray for cleaning engines, whitewall tires, vinyl and metal tops. Helps restore all types of oxidized paint surfaces.

PART NO.	DESCRIPTION	FORM	SHIP WT (LBS)
9.846-029.0	Super Concentrate Kit, 9 Pak*	Powder/Liquid	846
9.846-090.0	5 Gal. Product Label, Pkg. of 50		

**SPECIFICATIONS:** ■ pH: 10.74 ■ Foaming Action: High ■ Reaction in Hard Water (TDS): Best ■ Dilution Ratio: 1:150 ■ Color: Clear Green ■ Scent: Fresh ■ Hotsy Continuous Clean Additives **RECOMMENDED APPLICATIONS AND USES:** Automotive / Trucking / Construction, Stainless Steel, Aluminum / Polished Aluminum, Heavy Equipment, Glass, Fiberglass, Painted Surfaces, Whitewalls, Acid Rain, Pollution, Road Grime, Diesel Smoke

**HOTSY RED**

✓ Kosher Approved

Outstanding cleaning at a low cost. Ideal for heavy duty, automatic and manual vehicle washing applications. Use at the rate of 1 to 2 oz. per 100 gallons of wash water.

PART NO.	DESCRIPTION	FORM	SHIP WT (LBS)
8.904-829.0	50 lb Drum*	Powder	53
8.904-830.0	100 lb Drum*	Powder	104

**SPECIFICATIONS:** ■ pH: 12.05 ■ Foaming Action: Medium ■ Reaction in Hard Water (TDS): Good ■ Dilution Ratio: 1-2 oz/100 Gal ■ Color: Maroon ■ Scent: Sight Detergent ■ Hotsy Continuous Clean Additives **RECOMMENDED APPLICATIONS AND USES:** Automotive, Road Film, Grease / Oil, Trucking, Dirt, Bug Residue, Construction, Salts, Diesel Soot, Stainless Steel / Aluminum, Engine Cleaning, Fifth Wheels

**NYTRO**

✓ Kosher Approved

Truckers and fleet maintenance specialists swear by this heavy duty detergent. It makes diesel smoke stains, road film and gummy grease residue disappear. It's equally effective on floors, walls and windows. Use this powerful cleaner where other detergents and chemicals fail.

PART NO.	DESCRIPTION	FORM	SHIP WT (LBS)
8.904-929.0	5 Gallons	Liquid	47
9.846-021.0	Super Concentrate Kit*	Powder/Liquid	90
9.846-080.0	5 Gal. Product Labels, Pkg. of 50		

**SPECIFICATIONS:** ■ pH: 11.78 ■ Foaming Action: High ■ Reaction in Hard Water (TDS): Poor ■ Dilution Ratio: 1:120 ■ Color: Clear ■ Scent: Detergent ■ Hotsy Continuous Clean Additives **RECOMMENDED APPLICATIONS AND USES:** Automotive / Trucking / Aircraft, Grease / Cooking Oil, Aluminum, Carbon, Construction / Farm Equipment, Dirt, Food Industry, Acid Rain, Stainless Steel, Crates / Pens, Diesel Smoke, Mold / Mildew, Painted / Unpainted Surfaces, Floors / Walls, Road Film, Clay

**PANEL WASH**

✓ Kosher Approved

A highly effective, economical detergent designed for the truck and transportation industry. It contains a small amount of caustic and is effective as a "pre-spray" to attack the final layer of soil that other products might not penetrate.

PART NO.	DESCRIPTION	FORM	SHIP WT (LBS)
9.846-106.0	Super Concentrate Kit*	Powder/Liquid	53
9.846-107.0	Super Concentrate Kit, 8 Pak*	Powder/Liquid	423
9.846-086.0	5 Gal. Product Label, Pkg. of 50		

**SPECIFICATIONS:** ■ pH: 12.8 ■ Foaming Action: Medium ■ Reaction in Hard Water (TDS): Good ■ Dilution Ratio: 1:35 to 1:100 ■ Color: Purple ■ Scent: None ■ Hotsy Continuous Clean Additives **RECOMMENDED APPLICATIONS AND USES:** Trucking, Salts, Bug Residue, Construction, Carbon, Diesel Smoke, Asphalt / Tar, Exhaust Trails, Acid Rain

**POWER SHINE**

✓ Kosher Approved

High foaming detergent with increased dwell time. Specially formulated for washing vertical painted surfaces and removing bug residue, road film and oxidized paint leaving a shiny surface behind. Safe to use on aluminum and works well in cold water.

PART NO.	DESCRIPTION	FORM	SHIP WT (LBS)
8.904-912.0	5 Gallons	Liquid	48
9.846-008.0	Super Concentrate Kit*	Powder/Liquid	100
9.846-064.0	5 Gal. Product Label, Pkg. of 50		

**SPECIFICATIONS:** ■ pH: 12.8 ■ Foaming Action: High ■ Reaction in Hard Water (TDS): Best ■ Dilution Ratio: 1:100 to 1:150 ■ Color: Clear Blue Green ■ Scent: Fresh ■ Hotsy Continuous Clean Additives **RECOMMENDED APPLICATIONS AND USES:** Automotive / Trucking / Vehicles, Road Film, Grease / Oil, Construction / Farm Equipment, Salts / Clay / Dirt, Bug Residue, Stainless Steel, Whitewalls / Vinyl Tops, Diesel Smoke, Aluminum, Fiberglass, Painted / Unpainted Surfaces

\* Entire contents of each additive drum should be used at one time, do not attempt to make partial batches.

**VEHICLE PRE-SOAK**

✓ Kosher Approved

Used to remove stubborn soils like bugs, tar, oil and grease deposits on vehicles. Apply before washing in order to penetrate and break up soils. The more time allowed to soak, the less scrubbing is required.

PART NO.	DESCRIPTION	FORM	SHIP WT (LBS)
8.698-230.0	5 Gallons	Liquid	49
8.698-231.0	55 Gallons	Liquid	515

**SPECIFICATIONS:** ■ pH: 12.8 ■ Reaction in Hard Water (TDS): Good ■ Dilution Ratio: 1:60 ■ Color: Clear Blue ■ Scent: Citrus **RECOMMENDED APPLICATIONS AND USES:** Automotive, Road Film, Grease / Oil, Trucking, Salts, Bug Residue, Construction, Carbon, Diesel Smoke, Asphalt/Tar, Exhaust Trails

**RINSE AID**

✓ Kosher Approved

With a dilution ratio of 5000 to 1, this is an extremely economical additive for rinse cycles. Hotsy Rinse Aid prevents spotting on vehicles.

PART NO.	DESCRIPTION	FORM	SHIP WT (LBS)
8.905-609.0	5 Gallons	Liquid	46

**SPECIFICATIONS:** ■ pH: 7.58 ■ Foaming Action: Low ■ Reaction in Hard Water (TDS): Good ■ Dilution Ratio: 1:5000 ■ Color: Clear ■ Scent: None ■ Free Rinsing **RECOMMENDED APPLICATIONS AND USES:** Automotive, Aircraft Equipment, Fiberglass, Trucking, Heavy Equipment, Aluminum, Construction, Painted / Unpainted Surfaces, Stainless Steel

**VEHICLE TIRE & RIM CLEANER**

✓ Kosher Approved

Fast and easy way to deep clean the black rubber, road film and brake dust soils from your tires and rims. Simply spray, wait and rinse. This product should be used to clean tire and wheels before adding tire dressing. Make tire dressings look better and last longer. Safe to use on all tires. Safe for steel and aluminum wheels, including coated wheels.

PART NO.	DESCRIPTION	FORM	SHIP WT (LBS)
8.698-229.0	Qty 12, 1 Quart	Liquid	28

**SPECIFICATIONS:** ■ pH: 12.9 ■ Foaming Action: High ■ Reaction in Hard Water (TDS): Average ■ Dilution Ratio: Ready to Use ■ Color: Colorless ■ Scent: Detergent **RECOMMENDED APPLICATIONS AND USES:** Automotive / Trucking / Vehicles, Road Film, Grease / Oil, Construction / Farm Equipment, Whitewalls / Vinyl Tops, Aluminum

**DEGREASERS**

**RIPPER I Hotsy's #1 Recommended Degreaser**



✓ Kosher Approved

A highly concentrated, non-caustic cleaner for heavy equipment and trucks. This fast-acting cleaner is especially effective on off-road and grease-clogged equipment and great on hard-to-remove road film on tractor/trailers. Safe to use indoors and on all painted surfaces. Excellent for cleaning shop floors and walls where inside cleaning is necessary.

PART NO.	DESCRIPTION	FORM	SHIP WT (LBS)
8.904-846.0	5 Gallons	Liquid	47
8.904-847.0	55 Gallons	Liquid	506
9.846-009.0	Super Concentrate Kit*	Powder/Liquid	90
9.846-010.0	Super Concentrate Kit, 9 Pak*	Powder/Liquid	804
8.698-092.0	275 Gallon Tote	Liquid	2472
9.846-065.0	5 Gal. Product Label, Pkg. of 50		

**SPECIFICATIONS:** ■ pH: 12.85 ■ Foaming Action: Medium ■ Reaction in Hard Water (TDS): Good ■ Dilution Ratio: 1:100 ■ Color: Clear Pink-Violet ■ Scent: Slight Detergent ■ Hotsy Continuous Clean Additive **RECOMMENDED APPLICATIONS AND USES:** Automotive / Trucking / Aircraft, Food Industry, Grease / Cooking Oil, Carbon, Construction / Farm Equipment, Dirt, Aluminum, Acid Rain, Oil Field Equipment / Drill Pipe Tools, Crates / Pens, Diesel Smoke, Mold / Mildew, Painted / Unpainted Surfaces, Floors / Walls, Road Film, Stainless Steel

\* Entire contents of each additive drum should be used at one time, do not attempt to make partial batches.

✓ Kosher Approved

### RIPPER II

The serious big brother to Ripper I. Used when extra degreasing power for heavy equipment is needed. The detergent's superior cleaning action will handle the heavy grease oil and hydraulic oils. Has been used as a pre-paint wash and is not to be used on fine painted surfaces, galvanized, aluminum or magnesium surfaces.

PART NO.	DESCRIPTION	FORM	SHIP WT (LBS)
8.904-850.0	5 Gallons	Liquid	51
8.904-851.0	55 Gallons	Liquid	550
9.846-011.0	Super Concentrate Kit*	Powder/Liquid	93
9.846-091.0	Super Concentrate Kit, 9 Pak*	Powder/Liquid	2511
8.698-093.0	275 Gallon Tote	Liquid	2472
9.846-066.0	5 Gal. Product Label, Pkg. of 50		

**SPECIFICATIONS:** ■ **Use Caution: Wear Protective Gear** ■ pH: 13.34 ■ Foaming Action: Medium ■ Reaction in Hard Water (TDS): Poor ■ Dilution Ratio: 1:40 ■ Color: Red ■ Scent: Solvent ■ Hotsy Continuous Clean Additive **RECOMMENDED APPLICATIONS AND USES:** Construction Equipment, Heavy Equipment, Construction, Diesel Smoke, Mines, Fifth Wheels, Stainless Steel, Carbon, Oil Drillers, Off Road Machinery, Unpainted Surfaces, Grease / Oil, Food Plants, Degreasing, Engine Cleaning, Salts / Clay / Dirt

### RIPPER III

✓ Kosher Approved

This heavy-duty degreaser is ideal for use as a hood and vent cleaner and will also strip paint and powder coated surfaces. Also great for cleaning hood and vents at restaurants. **DO NOT USE on aluminum, magnesium, galvanized metal or fine painted surfaces.** Contains Sodium Hydroxide.

PART NO.	DESCRIPTION	FORM	SHIP WT (LBS)
8.904-839.0	5 Gallons	Liquid	51
8.904-840.0	55 Gallons	Liquid	550

**SPECIFICATIONS:** ■ **Use Caution: Wear Protective Gear** ■ pH: 13.72 ■ Foaming Action: Low ■ Reaction in Hard Water (TDS): Poor ■ Dilution Ratio: 1:40 ■ Color: Brown ■ Scent: Musty ■ Hotsy Continuous Clean Additive **RECOMMENDED APPLICATIONS AND USES:** Restaurants, Asian Food Grease, Carbon, Food Processing Plants, Deep Fat Fryers / Ovens, Heavy-Duty Degreasing, Food Processing Equipment, Burnt-On Food, Graffiti Removal, Hoods, Vents, Ducts

### CITRUS CLEAN

This citrus-based detergent additive increases any detergent's cleaning and degreasing power and is a great degreaser in its own right, plus it also enhances rinsing. Citrus Clean contains d-limonene which is a great "natural" degreaser.

PART NO.	DESCRIPTION	FORM	SHIP WT (LBS)
8.904-985.0	5 Gallons	Liquid	44
8.904-986.0	55 Gallons	Liquid	466

**SPECIFICATIONS:** ■ pH: 9.5-10.2 ■ Foaming Action: High ■ Reaction in Hard Water (TDS): Best ■ Dilution Ratio: 1:5 to 1:50 ■ Color: Clear Light Yellow ■ Scent: Citrus ■ Free Rinsing **RECOMMENDED APPLICATIONS AND USES:** Detergent Additive, Degreasing - All Surfaces, Grease / Oil



✓ Kosher Approved

## OIL FIELD & HEAVY EQUIPMENT

### HOTSY BROWN Hotsy's #1 Recommended Oil Field and Heavy Equipment Detergent



✓ Kosher Approved

This versatile, extra-strong detergent is caustic based for fast and thorough cleaning. Hotsy Brown is a non-butyl product that is particularly effective on carbon based deposits such as road film and exhaust stains, as well as dirt and grease. Not recommended for use on fine finishes, aluminum, galvanized metal or magnesium.

PART NO.	DESCRIPTION	FORM	SHIP WT (LBS)
8.915-455.0	5 Gallons	Liquid	48
8.915-453.0	55 Gallons	Liquid	515
9.846-044.0	Super Concentrate Kit*	Powder/Liquid	87
9.846-005.0	Super Concentrate Kit, 9 Pak*	Powder/Liquid	758
9.846-098.0	5 Gal. Product Label, Pkg. of 50		

**SPECIFICATIONS:** ■ **Use Caution: Wear Protective Gear** ■ pH: 13.4 ■ Foaming Action: Medium ■ Reaction in Hard Water (TDS): Good ■ Dilution Ratio: 1:50 ■ Color: Brown ■ Scent: Slight Detergent ■ Hotsy Continuous Clean Additive **RECOMMENDED APPLICATIONS AND USES:** Construction Equipment, Farm Equipment, Road Film, Diesel Smoke, Heavy Equipment, Fifth Wheel Grease, Off-Road Machinery, Degreasing, Stainless Steel, Unpainted Surfaces, Engine Cleaning, Grease / Oil, Carbon, Salts / Clay / Dirt

\* Entire contents of each additive drum should be used at one time, do not attempt to make partial batches.

**HOTSY ORANGE**

✓ Kosher Approved

Hotsy's moderate pH degreaser. This surfactant based non-caustic detergent was developed for people in the oil field that needed good degreasing and cleaning but also needed to be user friendly and have a pH of below 10.5. Orange is safe on painted surfaces and is very effective on carbon based deposits; road film and truck exhaust stains.

PART NO.	DESCRIPTION	FORM	SHIP WT (LBS)
9.846-100.0	Super Concentrate Kit*	Powder/Liquid	67
9.846-101.0	Super Concentrate Kit, 9 Pak*	Powder/Liquid	584
8.698-066.0	275 Gallon Tote*	Liquid	2472
9.846-102.0	5 Gal. Product Label, Pkg. of 50		

**SPECIFICATIONS:** ■ **Use Caution: Wear Protective Gear** ■ pH: 10.45 @ 5% solutions ■ **Foaming Action:** Medium ■ **Reaction in Hard Water (TDS):** Good ■ **Dilution Ratio:** 1:50 ■ **Color:** Orange ■ **Scent:** Citrus ■ Hotsy Continuous Clean Additive **RECOMMENDED APPLICATIONS AND USES:** Construction Equipment, Farm Equipment, Road Film, Diesel Smoke, Heavy Equipment, Fifth Wheel Grease, Off-Road Machinery, Degreasing, Stainless Steel, Unpainted Surfaces, Engine Cleaning, Grease / Oil, Oil & Gas Drilling, Salts / Clay / Dirt, Carbon [This product cannot be shipped via UPS.]

**ALUMINUM & STAINLESS STEEL CLEANERS**



**ADVANCED FORMULA ALUMINUM BRIGHTENER**

**Hotsy's #1 Recommended Aluminum and Stainless Steel Cleaner**

An extra-strength, acid-based, aluminum cleaner and brightener designed for non-polished aluminum tanks and trailers, aluminum wheels and for preparing aluminum surfaces for painting. This easy-to-apply formula restores aluminum and makes it look like new in just one application. Do NOT use on glass, polished aluminum or anodized aluminum. Contains no phosphates.

PART NO.	DESCRIPTION	FORM	SHIP WT (LBS)
8.698-227.0	5 Gallons	Liquid	50
8.698-228.0	55 Gallons	Liquid	537

**SPECIFICATIONS:** ■ **Use Caution: Wear Protective Gear** ■ 2.3@1:20 Dilution ■ **Foaming Action:** Low ■ **Reaction in Hard Water (TDS):** Best ■ **Dilution Ratio:** 1:5 to 1:20 ■ **Color:** Clear Light Straw ■ **Scent:** Sharp **RECOMMENDED APPLICATIONS AND USES:** Truck Trailers, Aluminum, Diesel Smoke, Road Film, Grease / Oils, Plastics, Welding Smut, Carbon

**HOTSY POLISHED ALUMINUM & STAINLESS STEEL CLEANER**

This non-etching specialty cleaner contains a concentrated blend of surfactants and glycol ethers to quickly penetrate and remove dirt, grease, oil, road film, diesel smoke and welding smut.

PART NO.	DESCRIPTION	FORM	SHIP WT (LBS)
8.904-749.0	5 Gallons	Liquid	48
8.904-751.0	55 Gallons	Liquid	521

**SPECIFICATIONS:** ■ **Use Caution: Wear Protective Gear** ■ pH: 1.12 ■ **Foaming Action:** Medium ■ **Reaction in Hard Water (TDS):** Best ■ **Dilution Ratio:** Undiluted ■ **Color:** Clear Straw ■ **Scent:** Citrus **RECOMMENDED APPLICATIONS AND USES:** Polished Aluminum, Road Film, Oil, Aluminum, Diesel Smoke, Grease, Stainless Steel, Welding Smut, Dirt

**YELLOW FEVER**

Yellow Fever is a powerful acidic cleaner and aluminum brightener to clean and restore stained aluminum surfaces, without dulling bright aluminum finishes. Yellow Fever is effective in removing diesel smoke, grease, carbon, oils and resins. Removes hard-water scale. Effective in removing mineral efflorescence from brick, masonry and concrete. **AVOID CONTACT WITH GLASS OR ANODIZED ALUMINUM.**

PART NO.	DESCRIPTION	FORM	SHIP WT (LBS)
8.698-061.0	5 Gallons	Liquid	50
8.698-062.0	55 Gallons	Liquid	537

**SPECIFICATIONS:** ■ pH: @5% Solution: 2.45 ■ **Foaming Action:** Low ■ **Reaction in Hard Water (TDS):** Good ■ **Dilution Ratio:** 25:1 to 15:1 ■ **Color:** Yellow ■ **Scent:** Sharp **RECOMMENDED APPLICATIONS AND USES:** Truck Trailers, Plastics, Welding Smut, Carbon, Road Film, Asphalt, Diesel Smoke, Hard-Water Scale, Tars / Resins, Aluminum and Bright Aluminum, Grease / Oils, Efflorescence on Masonry

\* Entire contents of each additive drum should be used at one time, do not attempt to make partial batches.

## ENVIRONMENTALLY FRIENDLY



✓ Kosher Approved

### VERDE ALL PURPOSE Hotsy's #1 Recommended Environmentally Friendly Detergent

A unique blend of environmentally preferred chemicals that provide great cleaning capabilities in all water conditions and all water temperatures. Superior foaming and fast-rinsing provide great results while saving money and the environment.

PART NO.	DESCRIPTION	FORM	SHIP WT (LBS)
8.698-079.0	5 Gallons	Liquid	44
8.698-080.0	55 Gallons	Liquid	485

**SPECIFICATIONS:** ■ pH: 8.64 ■ Foaming Action: High ■ Reaction in Hard Water (TDS): Good ■ Dilution Ratio: 150:1 ■ Color: Colorless ■ Scent: Slight Detergent **RECOMMENDED APPLICATIONS AND USES:** Truck Trailers, Road Film, Cars & Trucks, Plastics, Aluminum, Fine Automotive Finishes, Diesel Smoke, Grease/Oils, Carbon

✓ Kosher Approved

### ENVIRO-CLEAN

This phosphate-free detergent is excellent for communities where phosphates are prohibited from entering municipal wastewater treatment facilities. It's safe for all kinds of cleaning, yet has the cleaning power of highly concentrated degreasers. It is great on polished aluminum.

PART NO.	DESCRIPTION	FORM	SHIP WT (LBS)
8.904-927.0	5 Gallons	Liquid	47
9.846-026.0	Super Concentrate Kit*	Powder/Liquid	97
9.846-079.0	5 Gal. Product Label, Pkg. of 50		

**SPECIFICATIONS:** ■ pH: 12.32 ■ Foaming Action: High ■ Reaction in Hard Water (TDS): Good ■ Dilution Ratio: 1:150 ■ Color: Pink ■ Scent: Fresh & Clean ■ Phosphate Free ■ Hotsy Continuous Clean Additives **RECOMMENDED APPLICATIONS AND USES:** Automotive, Stainless Steel, Grease / Oils, Construction, Painted / Unpainted Surfaces, Diesel Smoke, Farm Machinery, Floors / Walls, Road Film, Restaurants, General Cleaning, Aluminum / Polished Aluminum

✓ Kosher Approved

### ENVIRO GARD 2

A quick-release detergent formulated for use with filtration-type or gray water recycle systems. This phosphate-free liquid releases oils and greases rapidly for maximum separation. Low solid content reduces build-up, allowing more cycles between discharge. Non-emulsifying.

PART NO.	DESCRIPTION	FORM	SHIP WT (LBS)
8.905-124.0	55 Gallons	Liquid	487
9.846-030.0	Super Concentrate Kit*	Powder/Liquid	42
9.846-094.0	Super Concentrate Kit, 9 Pak*	Powder/Liquid	373
9.846-083.0	5 Gal. Product Label, Pkg. of 50		

**SPECIFICATIONS:** ■ pH: @5% Solution: 10.48 ■ Foaming Action: Medium ■ Reaction in Hard Water (TDS): Good ■ Dilution Ratio: 1:60 ■ Color: Clear ■ Scent: Detergent ■ Phosphate Free ■ Hotsy Continuous Clean Additives **RECOMMENDED APPLICATIONS AND USES:** Recycle Systems / General Purpose Cleaner

## TRANSPORTATION SPECIALTY CLEANERS



✓ Kosher Approved

### SALT LICK Hotsy's #1 Recommended Transportation Detergent

Salt Lick is formulated to remove salt, calcium chloride and de-icing solution used on winter roads by breaking down the crystalline structure of ice melt products and prevents them from re-crystallizing so they can be washed away. Salt Lick is a dual-purpose concentrated detergent attacking heavy soils and road film.

PART NO.	DESCRIPTION	FORM	SHIP WT (LBS)
8.698-081.0	5 Gallons	Liquid	46
8.698-082.0	55 Gallons	Liquid	502

**SPECIFICATIONS:** ■ pH: 13.24 ■ Reaction in Hard Water (TDS): Best ■ Dilution Ratio: 1:16 to 1:100 ■ Color: Dark Red ■ Scent: Slight Detergent ■ Phosphate Free **RECOMMENDED APPLICATIONS AND USES:** Truck Trailers, Snow Plows, Automobiles, Fifth Wheels, Construction Equipment

✓ Kosher Approved

### 400 WAX

Added to a final rinse, this long-lasting, liquid wax creates a durable finish that improves a vehicle's appearance and keeps dirt from adhering to the surface. It gives added protection against salt, air pollution and acid rain. With a dilution ration of 2000 to 1, this is a highly economical wax.

PART NO.	DESCRIPTION	FORM	SHIP WT (LBS)
8.905-531.0	5 Gallons	Liquid	43

**SPECIFICATIONS:** ■ pH: 5.32 ■ Foaming Action: None ■ Reaction in Hard Water (TDS): Best ■ Dilution Ratio: 1:2000 ■ Color: Straw ■ Scent: Musk ■ Free Rinsing **RECOMMENDED APPLICATIONS AND USES:** Automotive, Hot Waxes, Vinyl Tops, Trucking, Painted Surfaces, Whitewalls, Vehicles, Stainless Steel, Fiberglass

\* Entire contents of each additive drum should be used at one time, do not attempt to make partial batches.



✓ Kosher Approved

### AERO ONE

Approved for aircraft use, this non-toxic compound has met rigorous standards set by the aerospace industry (Aerospace Specification AMS-1526). High concentrations of corrosion inhibitors fight effects of salt, air pollution and acid rain. Meets Aerospace Materials Specification AMS-1526C Cleaner for Aircraft Exterior Surfaces, Water-Miscible, Pressure-Spraying Type.

PART NO.	DESCRIPTION	FORM	SHIP WT (LBS)
8.905-634.0	5 Gallons	Liquid	47
8.905-636.0	55 Gallons	Liquid	505

**SPECIFICATIONS:** ■ pH: 12.5 ■ Foaming Action: High ■ Reaction in Hard Water (TDS): Good ■ Dilution Ratio: 1:50 ■ Color: Red ■ Scent: Solvent ■ Free Rinsing ■ Hotsy Continuous Clean Additives **RECOMMENDED APPLICATIONS AND USES:** Aircraft, Painted / Unpainted Surfaces, Degreasing, Cars / Trucks, Aluminum, Stainless Steel, Ground Support Equipment, Air Pollution, Acid Rain, Road Film / Salt, Oxidized Paint, Exhaust Trails

### CARBON-ATE PLUS

✓ Kosher Approved

A special wax is added to Carbon-Ate Plus to provide a durable, attractive finish that keeps dirt from adhering to surfaces and protects them against salt, air pollution and acid rain. Easy to rinse and it reduces water spotting. It works great on polished aluminum.

PART NO.	DESCRIPTION	FORM	SHIP WT (LBS)
8.904-832.0	5 Gallons	Liquid	47
9.846-019.0	Super Concentrate Kit*	Powder/Liquid	94
9.846-078.0	5 Gal. Product Label, Pkg. of 50		

**SPECIFICATIONS:** ■ pH: 12.48 ■ Foaming Action: High ■ Reaction in Hard Water (TDS): Best ■ Dilution Ratio: 1:150 ■ Color: Green ■ Scent: Slight Detergent ■ Free Rinsing ■ Hotsy Continuous Clean Additive **RECOMMENDED APPLICATIONS AND USES:** Automotive, Painted Surfaces, Road Film, Acid Rain, Trucking, Bug Residue, Diesel Smoke, Pollution, Vehicles, Stainless Steel, Grease / Oil, Salts / Clay / Dirt, Aluminum, Hot Waxes, Exhaust Trails, Vinyl Tops

### POWER SHINE PLUS

✓ Kosher Approved

A special wax is added to provide a durable, attractive finish that keeps dirt from adhering to surfaces and protects them against salt, air pollution and acid rain. Helps restore oxidized paint surfaces of all types. Easy to rinse; reduced water spotting. It is great on polished aluminum.

PART NO.	DESCRIPTION	FORM	SHIP WT (LBS)
8.904-817.0	5 Gallons	Liquid	48
9.846-018.0	Super Concentrate Kit*	Powder/Liquid	100
9.846-077.0	5 Gal. Product Label, Pkg. of 50		

**SPECIFICATIONS:** ■ pH: 12.8 ■ Foaming Action: High ■ Reaction in Hard Water (TDS): Best ■ Dilution Ratio: 1:150 ■ Color: Blue-Green ■ Scent: Floral-Herbal ■ Free Rinsing ■ Hotsy Continuous Clean Additive **RECOMMENDED APPLICATIONS AND USES:** Automotive, Grease / Oils, Polished Aluminum, Trucking, Road Film, Exhaust Trails, Construction, Diesel Smoke / Carbon, Bug Residue, Aircraft Equipment, Oxidized Paint, Dirt / Salts / Clay

## INSTITUTION & FOOD PREPARATION

### CARBOCHLOR Hotsy's #1 Recommended for Institution & Food Prep Detergent



✓ NSF

✓ Kosher Approved

A special emulsifying formula with high powered bleach for food processing plants. Excellent on tough odors, stains, dirt, oils and fats left behind on equipment, floors, and walls. Chlorinated for extra punch. NSF Registered for use in federally inspected food plants, non-food compounds A1.

PART NO.	DESCRIPTION	FORM	SHIP WT (LBS)
8.904-979.0	5 Gallons	Liquid	46
8.904-980.0	55 Gallons	Liquid	495
9.846-016.0	Super Concentrate Kit*	Powder/Liquid	54
9.846-017.0	Super Concentrate Kit, 9 Pak*	Powder/Liquid	468
9.846-076.0	5 Gal. Product Label, Pkg. of 50		

**SPECIFICATIONS:** ■ pH: 12.46 ■ Foaming Action: High ■ Reaction in Hard Water (TDS): Good ■ Dilution Ratio: 1:60 ■ Color: Clear ■ Scent: Chorline and Solvent ■ Hotsy Continuous Clean Additive **RECOMMENDED APPLICATIONS AND USES:** Packing Plants, Agriculture, Grease / Oils, Animal Fats, Farm Industry, Stainless Steel, Aluminum, Floors / Walls, Veterinarians, Seafood Oils / Fish, Crates / Pens, Tough Odors, Food Industry, Mold / Mildew, Baked on Carbon, Dirt / Stains

\* Entire contents of each additive drum should be used at one time, do not attempt to make partial batches.

### DUCT BOSS — HOOD AND DUCT DEGREASER

✓ Kosher Approved

Duct Boss is specifically designed to remove the dangerous build-up of grease in exhaust hoods of food cooking establishments. Through a hot water pressure washer, fast effective removal restores hood and ducts to a clean, safe result. NSF approved, nonfood

PART NO.	DESCRIPTION	FORM	SHIP WT (LBS)
8.759-490.0	5 Gallons	Liquid	55
8.759-491.0	55 Gallons	Liquid	590
8.759-489.0	2 x 2.5 Gallons	Liquid	55

**SPECIFICATIONS:** ■ Use Caution: Wear Protective Gear ■ pH: 13.7 ■ Foaming Action: Medium ■ Reaction in Hard Water (TDS): Good ■ Dilution Ratio: 1:30 ■ Color: Straw ■ Scent: None **RECOMMENDED APPLICATIONS AND USES:** Exhaust Hoods, Ducts, Grills, Fryers, Broilers, Ovens

### MIRACLE WIZZ

✓ Kosher Approved

An unsurpassed liquid for removing baked-on carbon found in food preparation, bakeries, restaurants, food processing plants, etc. It is also great for engine degreasing and graffiti removal.

PART NO.	DESCRIPTION	FORM	SHIP WT (LBS)
8.904-924.0	5 Gallons	Liquid	52
9.846-013.0	Super Concentrate Kit*	Powder/Liquid	129
9.846-067.0	5 Gal. Product Label, Pkg. of 50		

**SPECIFICATIONS:** ■ pH: 13.08 ■ Foaming Action: Medium ■ Reaction in Hard Water (TDS): Poor ■ Dilution Ratio: 1:5 to 1:100 ■ Color: Brown ■ Scent: Musty ■ Hotsy Continuous Clean Additives **RECOMMENDED APPLICATIONS AND USES:** Food Processing, Smokehouse Cleaner, Degreasing, Mol, Bakeries, Baked-on Carbon, Grease / Oils, Mildew, Restaurants, Stainless Steel, Painted, Cooking Oils, Automotive, Engine Degreasing, Unpainted Surfaces, Graffiti Removal

## SPECIALTY CLEANERS



### CON-B-GONE Hotsy's #1 Recommended Specialty Cleaner

Con-B-Gone is a fast acting acidic product that when applied to ready mix trucks, forms and tools softens dried concrete splatter allowing it to be rinsed away with a hot or cold water pressure washer. Con-B-Gone's foaming formula makes application over large areas quick and easy. A Hotsy Foamer increases dwell time and maximizes end-results!

PART NO.	DESCRIPTION	FORM	SHIP WT (LBS)
8.698-083.0	5 Gallons	Liquid	45
8.698-084.0	55 Gallons	Liquid	494
8.698-085.0	275 Gallon Tote	Liquid	2472

**SPECIFICATIONS:** ■ pH: 2.16 ■ Foaming Action: Medium ■ Reaction in Hard Water (TDS): Good ■ Dilution Ratio: Ready to Use ■ Color: Light Yellow ■ Scent: Sharp **RECOMMENDED APPLICATIONS AND USES:** Concrete Trucks, Mixing Equipment, Tools, Construction Vehicles

### HOTSY "99"

A highly concentrated formulation of non-fuming inhibited phosphoric acid and surfactants that remove concrete, welding smut, hard-water scale, rust, mortar, and diesel smoke. It is ideal for cleaning and descaling concrete trucks, metal surfaces, equipment, bricks and glass. DO NOT USE on polished aluminum.

PART NO.	DESCRIPTION	FORM	SHIP WT (LBS)
8.904-842.0	5 Gallons	Liquid	51
8.904-843.0	55 Gallons	Liquid	546

**SPECIFICATIONS:** ■ Use Caution: Wear Protective Gear ■ pH: 1.4 ■ Foaming Action: Medium ■ Reaction in Hard Water (TDS): Best ■ Dilution Ratio: 1:10 to 1:20 ■ Color: Clear ■ Scent: Citrus **RECOMMENDED APPLICATIONS AND USES:** Trucks, Stainless Steel / Steel, Bricks, Heavy Equipment, Rust, Construction, Mortar, Diesel Smoke, Vehicles, Hard Water Scale

### COIL CONDITIONER

A special conditioner for removing hard water deposits and scale from the internal surface of heating coils.

PART NO.	DESCRIPTION	FORM	SHIP WT (LBS)
8.904-764.0	Qty 12, 2 Lbs Container	Powder	28

**SPECIFICATIONS:** ■ pH: @ 1% Solution: 1.48 ■ Foaming Action: Medium ■ Reaction in Hard Water (TDS): Best ■ Dilution Ratio: 2 lbs to 5 gallons ■ Color: White ■ Scent: Slight Detergent **RECOMMENDED APPLICATIONS AND USES:** Pressure Washers, Boilers, Rust Remover

✓ Kosher Approved

### LIQUID FOAMER

When combined with most detergents, it creates mountains of suds and increases dwell time to loosen dirt, grease and oil. Designed for use with foam generators and revolving brushes.

PART NO.	DESCRIPTION	FORM	SHIP WT (LBS)
8.905-527.0	5 Gallons	Liquid	46

**SPECIFICATIONS:** ■ pH: 6.78 ■ Foaming Action: High ■ Reaction in Hard Water (TDS): Good ■ Dilution Ratio: 1:25 to 1:100 ■ Color: Pale Yellow ■ Scent: Slight Detergent **RECOMMENDED APPLICATIONS AND USES:** Food Plants, Foaming Brushes, Detergent Additive, Vehicles, Foam Booster / Foam Stabilizer, Vertical Surfaces

\* Entire contents of each additive drum should be used at one time, do not attempt to make partial batches.

**HOTSY PHOSPHATIZER NO. 2**

A complete and economical detergent and phosphatizing system for one-step phosphatizing of iron and steel parts. Phosphatizer No. 2 can be used at temperatures ranging from 120°F to 180°F. Equally effective in spray, dip and wipe-on applications. A quality product with 20+ years of successful history in the industry.

PART NO.	DESCRIPTION	FORM	SHIP WT (LBS)
8.904-977.0	5 Gallons	Liquid	51
8.904-978.0	55 Gallons	Liquid	525
9.846-015.0	Super Concentrate Kit*	Powder/Liquid	103
9.846-069.0	5 Gal. Product Label, Pkg. of 50		

**SPECIFICATIONS:** ■ pH: 3.08 ■ Foaming Action: Medium ■ Reaction in Hard Water (TDS): Good ■ Dilution Ratio: 1:16 to 1:32 ■ Color: Clear ■ Scent: Detergent  
**RECOMMENDED APPLICATIONS AND USES:** Safe for Use with Hotsy Pressure Washers, Paint Preparation

**FAT CAP GRAFFITI REMOVER Brick, Masonry & Concrete**



✓ K kosher Approved

An easy-to-use liquid graffiti remover designed for use on exterior brick, masonry and concrete surfaces. Fat Cap Graffiti Remover cleaner is deep penetrating and fast acting for effective and thorough loosening of spray paint graffiti and removal of graffiti from the surface being treated.

PART NO.	DESCRIPTION	FORM	SHIP WT (LBS)
8.698-028.0	Qty 12, 1 Quart	Liquid	27
8.698-027.0	Qty 4, 1 Gallon	Liquid	34

**SPECIFICATIONS:** ■ pH: @ 5% Solution: 12.8 ■ Foaming Action: Low ■ Dilution Ratio: Use Undiluted ■ Color: Clear Yellow ■ Scent: Alcohol **RECOMMENDED APPLICATIONS AND USES:** Concrete, Masonry, Painted Masonry, Brick, Stone, Painted Stone

**VITAL OXIDE Cleaner & Disinfectant**

✓ Health Canada Registered      ✓ NSF  
 ✓ EPA Registered

Vital Oxide is used to disinfect and sanitize just about any surface. Vital Oxide can be used as a disinfectant and diluted to a sanitizer for spray and/or foam application. There's no smell and it's safe for animals and humans.

**SPECIFICATIONS:** ■ pH: 8.0-9.0  
 ■ Dilution Ratio: Ready to Use / 9:1 / 5:1 ■ Color: Clear ■ Scent: Mild

**RECOMMENDED APPLICATIONS AND USES:** Food Processing, Restaurants, Boats/Ships **Veterinary:** Kennels, transport vehicles, **Education:** Schools, Daycare, Gyms & Locker Rooms **Healthcare:** Nursing Homes, Laundry Rooms, Pharmacies, Ambulances

PART NO.	DESCRIPTION	FORM	SHIP WT (LBS)
8.639-560.0	Qty 6, 1 Quart (US only)	Liquid	15
8.639-558.0	Qty 4, 1 Gallon (US only)	Liquid	36
8.639-559.0	Qty 4, 1 Gallon (Canada only)	Liquid	36
8.644-292.0	5 Gallons (US only)	Liquid	43
8.758-937.0	5 Gallons (Canada only)	Liquid	43
8.642-823.0	15 Gallons (US only)	Liquid	127
8.698-112.0	55 Gallons (US only)	Liquid	585
8.756-449.0	55 Gallons (Canada only)	Liquid	585
8.759-565.0	Qty 12, 3 Oz (US Only)		
8.644-439.0	Vital Oxide Secondary Label - Full Strength 3" x 3"		
8.642-868.0	Vital Oxide Secondary Label - 5:1 Dilution 3" x 3"		
8.642-869.0	Vital Oxide Secondary Label 9:1 Dilution 3" x 3"		



**NUBLEND DISINFECTANT 220 Multi-purpose Disinfecting Spray**

✓ EPA Registered

NuBlend Disinfectant 220 is the latest in disinfectant cleaning technology, formulated to disinfect an impressive list of microbial pathogens with reduced contact times when compared to other disinfectants. It is effective against a wide range of bacteria, viruses and fungi, including Pseudomonas Aeruginosa, Staphylococcus Aureus, MRSA, HIV-1, HBV, HCV and Avian Influenza. Ready to use with no mixing required, EPA registered.

PART NO.	DESCRIPTION	FORM	SHIP WT (LBS)
8.644-723.0	12x1 Quarts	Liquid	30
8.644-722.0	4x1 Gallon	Liquid	36
8.644-721.0	5 Gallons	Liquid	43
8.644-720.0	15 Gallons	Liquid	127
8.644-719.0	55 Gallons	Liquid	585
8.644-718.0	275 Gallons [made to order]	Liquid	2450
8.759-187.0	Disinfectant 220 Secondary Label - Full strength, pack of 25, 4.25" x 9.50"		

**SPECIFICATIONS:** ■ pH: @ 1% Solution: 12.2 ■ Dilution Ratio: Ready to Use ■ Foaming Action: Low ■ Color: Clear Liquid ■ Scent: Mild/Mint  
**RECOMMENDED APPLICATIONS AND USES:** Schools and Daycare Facilities, Food Processing, Healthcare, Hospitality, Veterinary, Cruise lines



[NOT AVAILABLE IN CANADA]

**NUBLEND BARRAGE Multi-purpose Disinfecting Spray**

✓ EPA Registered

Formulated to disinfect microbial pathogens with reduced contact times when compared to other disinfectants. It is effective against a wide range of bacteria and viruses, including Pseudomonas Aeruginosa, Staphylococcus Aureus, MRSA, HIV-1, HBV, HCV and Avian Influenza.

PART NO.	DESCRIPTION	FORM	SHIP WT (LBS)
8.759-345.0	4 x 1 Gallon	Liquid	36
8.759-346.0	5 Gallons	Liquid	43
8.759-347.0	55 Gallons	Liquid	585
8.759-386.0	Nublend Barrage Secondary Label – 1:64 dilution, pack of 25, 4.25" x 9.50"		

**SPECIFICATIONS:** ■ pH: @ 1:64 dilution 10.7 ■ Dilution Ratio: 1:64 ■ Foaming Action: Low ■ Color: Red ■ Scent: Fresh  
**RECOMMENDED APPLICATIONS AND USES:** Schools and Daycare Facilities, Food Processing, Healthcare, Hospitality, Veterinary, Cruise lines [NOT AVAILABLE IN CANADA]



**PARTS WASHER**

**TUBMATE GENERAL PURPOSE DETERGENT Hotsy's #1 Recommended Parts Washer Detergent**



A phosphate-free super-concentrated liquid. Works great with automatic detergent injectors; can be automatically metered into aqueous parts washers. Quick oil release and solvent free. Heavy duty rust and corrosion inhibitor package protects against flash rusting; defoamers reduce foam in your aqueous parts washer.

PART NO.	DESCRIPTION	FORM	SHIP WT (LBS)
8.905-144.0	5 Gallons	Liquid	51
8.905-150.0	55 Gallons	Liquid	548
9.846-032.0	Super Concentrate Kit*	Powder/Liquid	94
9.846-084.0	5 Gal. Product Label, Pkg. of 50		

**SPECIFICATIONS:** ■ pH: 13.1 ■ Foaming Action: Non-foaming ■ Reaction in Hard Water (TDS): Good ■ Dilution Ratio: 1.0 - 12.0 oz / gallon ■ Color: Clear ■ Scent: Detergent ■ Phosphate Free **RECOMMENDED APPLICATIONS AND USES:** Aqueous Parts Washers, Iron / Steel, Copper, Painted Parts, Magnesium, Plastic

**TUBMATE TORQUE**

Hotsy Tubmate Torque soft metal powder is a heavy duty parts washer detergent specially formulated for use on softer materials such as brass, copper, stainless steel and plastics. Higher alkalinity and solvent-based cleaning booster provides effective penetration and removal of difficult oil, grease and carbon-based soils while protecting softer materials.

PART NO.	DESCRIPTION	FORM	SHIP WT (LBS)
8.905-262.0	40 Lbs Pail	Powder	42
8.905-263.0	400 Lbs Drum	Powder	415

**SPECIFICATIONS:** ■ pH: 11.9 @ 1% solution ■ Foaming Action: Non-foaming ■ Reaction in Hard Water (TDS): Best ■ Dilution Ratio: 0.5 - 2.0 oz. per gallon ■ Color: Yellow ■ Scent: Citrus **RECOMMENDED APPLICATIONS AND USES:** Aqueous Parts Washers, Degreaser, Aluminum, Copper / Brass, Stainless Steel / Steel, Parts made of soft metal

**TUBMATE IRON & STEEL CLEANER**

A heavy-duty liquid detergent, perfect for truckers, manufacturers, railroads, food processors, bakeries and other applications requiring the removal of heavy grease, baked-on carbon, loose paint and coatings. Rust and corrosion inhibitors and heavy defoamer package. Not an EPA hazardous waste at a pH of less than 12.5.

PART NO.	DESCRIPTION	FORM	SHIP WT (LBS)
8.905-087.0	5 Gallons	Liquid	48

**SPECIFICATIONS:** ■ pH: 12.98 ■ Foaming Action: Non-foaming ■ Reaction in Hard Water (TDS): Good ■ Dilution Ratio: 1:1 to 1:40 ■ Color: Cream Amber ■ Scent: Mild **RECOMMENDED APPLICATIONS AND USES:** Trucking, Railroads, Heavy Grease, Bakeries, Aqueous Parts Washer, Baked-on Carbon, Food Processing, Iron / Steel, Loose Paint, Manufacturing, Stainless Steel, Pots / Pans

**TUBMATE ALL PURPOSE DETERGENT (POWDER)**

Tubmate All Purpose Cleaner is a highly concentrated powder parts washer detergent that is effective in cleaning heavy grease and oil buildup on parts made of ferrous metal. It contains extra corrosion inhibitor for protection against corrosion and flash rusting, and an enhanced non-foaming formula to assist with foam control in the parts washer sump.

PART NO.	DESCRIPTION	FORM	SHIP WT (LBS)
8.904-779.0	40 Lbs Pail	Powder	42
8.904-782.0	100 Lbs Drum	Powder	115
8.904-785.0	450 Lbs Drum	Powder	450

**SPECIFICATIONS:** ■ pH: 12.4 ■ Foaming Action: Non-foaming ■ Reaction in Hard Water (TDS): Best ■ Dilution Ratio: 0.5 - 2.0 oz. per gallon ■ Color: White Powder ■ Scent: None **RECOMMENDED APPLICATIONS AND USES:** Diesel Engines, Ferrous Metal Parts, Rolling Mill Equipment, Oil & Grease, Burnt Hydrocarbons, Varnish, Carbon, Mastic, Rubber

\* Entire contents of each additive drum should be used at one time, do not attempt to make partial batches.

**FINISH LINE**

Hotsy Finish Line is a moderate pH, water-based detergent formulated for use in manual parts washers and aqueous parts sinks. It removes greases, oils and grime, and can be used on most surfaces, including steel, stainless steel, brass, aluminum, copper and plastics. This detergent has a pleasant citrus odor.

PART NO.	DESCRIPTION	FORM	SHIP WT (LBS)
8.904-738.0	5 Gallons	Liquid	48

**SPECIFICATIONS:** ■ pH: 9.9 @ 5% Solution: 7.0 - 9.0 ■ Foaming Action: Low ■ Reaction in Hard Water (TDS): Good ■ Dilution Ratio: 5 Gallons to 16 Gallons ■ Color: Honey ■ Scent: Citrus **RECOMMENDED APPLICATIONS AND USES:** Manual parts washers, Automotive, Trucking, Degreaser, Oils, Plastics, All Metals, Painted Parts

**VAPOR CORROSION INHIBITOR**

✓ Kosher Approved

Especially effective in inhibiting rust in top and front-load automatic parts washers. It contains a superior blend of rust and corrosion inhibitors that give outstanding protection in both the liquid and vapor phase. This helps protect steel and prevents rust in automatic parts washers. It also helps prevent rust and corrosion on metal parts being cleaned.

PART NO.	DESCRIPTION	FORM	SHIP WT (LBS)
8.905-168.0	Qty 4, 1 Gallon	Liquid	37
8.905-169.0	5 Gallons	Liquid	46
8.905-170.0	55 Gallons	Liquid	493

**SPECIFICATIONS:** ■ pH: 10.2 ■ Foaming Action: None ■ Reaction in Hard Water (TDS): Good ■ Dilution Ratio: 10 oz. per 25 gallons ■ Color: Clear ■ Scent: Solvent **RECOMMENDED APPLICATIONS AND USES:** Soak Tanks, Rinse Water, Ultrasonic Cleaning, Recycle Systems, Automatic Parts Washers

**HOTSY DEFOAMER**

This defoamer is added to parts-washer cleaning solutions to reduce foam buildup. Hotsy Defoamer does not interfere with the detergent's normal cleaning ability.

PART NO.	DESCRIPTION	FORM	SHIP WT (LBS)
8.904-652.0	Qty 4, 1 Gallon Containers	Liquid	36
8.904-653.0	55 Gallons	Liquid	495

**SPECIFICATIONS:** ■ pH: 8.5 ■ Reaction in Hard Water (TDS): Good ■ Dilution Ratio: 1.0 - 2.0 oz / Gallon ■ Color: Opaque White ■ Scent: None **RECOMMENDED APPLICATIONS AND USES:** Aqueous Parts Washers

**PAINT & POWDER COAT STRIPPER**

Hotsy Paint & Powder Coat Remover is a fast and effective alkaline stripper. It dissolves all types of stubborn paint and powder coats, including epoxy finishes. Do NOT use on aluminum, magnesium or galvanized metals. With a use dilution pH of less than 12.5, this product is NOT EPA hazardous waste.

PART NO.	DESCRIPTION	FORM	SHIP WT (LBS)
8.905-099.0	5 Gallons	Liquid	48

**SPECIFICATIONS:** ■ pH: 13.5 ■ Foaming Action: Non-foaming ■ Reaction in Hard Water (TDS): Best ■ Dilution Ratio: Undiluted ■ Color: Hazy Brown ■ Scent: Musty **RECOMMENDED APPLICATIONS AND USES:** Iron & Steel

**FLOOR CARE**

**FLOOR WASH**

✓ Kosher Approved

Designed for use as a floor cleaner for food, automotive and manufacturing industries. It can be used with hot or cold water and is formulated with a color indicator for control of concentration and strength, and to insure uniform coverage and rinsing.

PART NO.	DESCRIPTION	FORM	SHIP WT (LBS)
8.749-836.0	40-lb. Pail	Powder	44
8.749-837.0	100-lb. Drum	Powder	103

**SPECIFICATIONS:** ■ pH: @ 1% Solution: 11.92 ■ Foaming Action: Low to Medium ■ Reaction in Hard Water (TDS): Good ■ Dilution Ratio: See mix instructions ■ Color: Orange-Yellow ■ Scent: Citrus ■ Hotsy Continuous Clean Additives **RECOMMENDED APPLICATIONS AND USES:** Automotive, Concrete, Driveways, Decks / Fences, Manufacturing, Floors / Walls, Floor Scrubbers, Grease / Oils, General Cleaning



**SHOP FLOOR CLEANER**

✓ Kosher Approved

Specially designed to break up and lift petroleum based, greasy soils commonly found in equipment repair shops. Designed for machine use. Won't harm epoxy finishes, floor paint when used as directed. Phosphate-free. Effective on any floor surface. Use 1 fluid ounce of product per gallon for routine cleaning. For heavier soil accumulations, use up to 2 ounces per gallon.

PART NO.	DESCRIPTION	FORM	SHIP WT (LBS)
8.698-131.0	5 Gallons	Liquid	47
8.698-132.0	55 Gallons	Liquid	512
8.698-133.0	275 Gallons	Liquid	2,815

**SPECIFICATIONS:** ■ Use Caution: Wear Protective Gear ■ pH: 13.26 ■ Foaming Action: Medium ■ Reaction in Hard Water (TDS): Best ■ Dilution Ratio: 1:128 ■ Color: Clear Light Red ■ Scent: Solvent **RECOMMENDED APPLICATIONS AND USES:** Shop Floors, Equipment Rooms

**KÄRCHER BUILDING CARE**

PART NO.	DESCRIPTION	SIZE	DILUTION	DESCRIPTION
<b>Red Carpet</b>				
8.695-207.0	Red Carpet Super Pre-Spray	4 x 1 gal case	1:16	blue-green color, citrus scent, medium foam
8.695-209.0	Red Carpet Super Conditioning Rinse	4 x 1 gal case	1:128	green color, citrus scent, low foam
8.695-210.0	Red Carpet Extraction Cleaner	4 x 1 gal case	1:128	bright blue color, citrus scent, low foam
8.695-211.0	Red Carpet Wool & Natural Fiber Cleaner	4 x 1 gal case	1:128	slate blue color, citrus scent, low foam
8.695-213.0	Red Carpet Liquid Defoamer	4 x 1 gal case	1:128	no added fragrance
8.695-218.0	Red Carpet Enzyme Deodorizer	4 x 1 gal case	1:4	amber col, citrus scent
8.695-219.0	Red Carpet Odor Neutralizer	4 x 1 gal case	1:128	clear, floral scent
8.695-222.0	Red Carpet Pro Spotter	12 x 1 qt case	1:1	clear, no added fragrance
8.628-441.0	2-Gallon Pump Sprayer with Wand			
<b>iCapsol™ Encapsulating Chemical</b>				
8.695-226.0	iCapsol™ encapsulating chemical	4 x 1 gal case	1:16	amber color, no added fragrance
8.695-469.0	iCapsol™ encapsulating chemical	12 x 1 pt case	1:16	amber color, no added fragrance
8.695-227.0	iCapsol™ encapsulator/protector	4 x 1 gal case	1:16	amber color, no added fragrance
8.695-470.0	iCapsol™ encapsulator/protector	12 x 1 pt case	1:16	amber color, no added fragrance
8.695-643.0	iCapsol™ encapsulator/protector	5 gallon	1:16	amber color, no added fragrance
<b>Professional Multi-Purpose &amp; Daily Cleaner</b>				
8.759-332.0	Professional Multi-Purpose & Daily Cleaner	12 x 1 qt case	RTU	General cleaning, multi surfaces
8.759-331.0	Professional Multi-Purpose & Daily Cleaner	4 x 1 gal case	RTU	General cleaning, multi surfaces
<b>Gum Remover Detergents</b>				
8.641-480.0	SG3 Bp chemical bottle	20 x 90 ml	1:1	
<b>Compass™ Chemical</b>				
8.695-241.0	Compass™ Clean	4 x 1 gal case	RTU	Food service cleaner/degreaser
8.695-242.0	Compass™ Shine	4 x 1 gal case	RTU	Concentrated bathroom cleaner/deodorizer
8.695-243.0	Compass™ Rinse	12 x 1 qt case		Spot free drying agent
<b>Kärcher Neutral Floor Cleaner</b>				
8.698-102.0	Kärcher Neutral Floor Cleaner	4 x 1 gal	1:128	Daily cleaning on finished/non-finished floors.
8.698-103.0	Kärcher Neutral Floor Cleaner	5 gal	1:128	Daily cleaning on finished/non-finished floors.
8.698-104.0	Kärcher Neutral Floor Cleaner	55 gal drum	1:128	Daily cleaning on finished/non-finished floors
<b>Kärcher Warehouse Floor Cleaner</b>				
8.698-107.0	Kärcher Warehouse Floor Cleaner	5 gal	1:128	Daily cleaning on warehouse/industrial floors.
8.698-108.0	Kärcher Warehouse Floor Cleaner	55 gal drum	1:128	Daily cleaning on warehouse/industrial floors.
8.698-109.0	Kärcher Warehouse Floor Cleaner	275 gal tote	1:128	Daily cleaning on warehouse/industrial floors
<b>Ice Breaker Freezer Cleaner</b>				
8.759-330.0	Ice Breaker Freezer Cleaner	4 x 1 gal	RTU	Clear blue, freezers and cold storage areas
8.759-329.0	Ice Breaker Freezer Cleaner	5 gal	RTU	Clear blue, freezers and cold storage areas
8.759-328.0	Ice Breaker Freezer Cleaner	55 gal drum	RTU	Clear blue, freezers and cold storage areas
<b>Tire Mark Remover and Pre-Soak</b>				
8.759-327.0	Tire Mark Remover and Pre-Soak	12 x 1 qt case	RTU	Clear yellow, citrus, shop floors, concrete
8.759-326.0	Tire Mark Remover and Pre-Soak	4 x 1 gal case	RTU	Clear yellow, citrus, shop floors, concrete
8.759-325.0	Tire Mark Remover and Pre-Soak	55 gal drum	RTU	Clear yellow, citrus, shop floors, concrete



# **PROFESSIONAL** FLOOR CARE



## IDENTIFYING KÄRCHER EQUIPMENT BY NAME

All Kärcher branded machines are named systematically so that every machine name explains what the product is. Floor care product names range from a direct to indirect relation to the product, such as BV for Backpack Vacuum to KM for a Sweeper. Below is a chart to help with identifying Kärcher equipment by name.



### FLOOR CARE MACHINE NAMES

Model		CAPACITY LITERS / GALLONS		CLEANING PATH CM / Inches		OPTIONS / FEATURES	
KM	= Sweeper	4	= 1	1	= .4	BP	= Battery Powered
Puzzi	= Spotter or Box & Wand Extractor	25	= 6.6	4	= 1.6	C	= Scrubbers = Pad Assist
NT	= Wet/Dry Vacuum	30	= 7.9	12	= 5	C	= Extractors = Compact
BR	= Scrubber with Cylindrical Brushes	35	= 9.25	20	= 8	AP	= Semi-Automatic Filter Cleaning System
BD	= Scrubber with Disc Brushes	38	= 10.0	30	= 12	W	= Scrubbers = Traction Drive
B	= Scrubber	40	= 10.6	40	= 16	HEPA	= HEPA Level Air Filtration
SG	= Steamer	48	= 12.68	50	= 20	Tact	= Triggered Airdraft Cleaning Technology
SGV	= Steamer Vacuum	50	= 13.21	175	= 69	Te	= Automatic Power Outlet
SG1	= Gum Remover	51	= 13.47			R	= Ride-On Machine
AB	= Air Blower	60	= 15.85				
BV	= Backpack Vacuum	68	= 17.96				
CV	= Upright Vacuum	70	= 18.49				
EB	= Compact Sweeper	75	= 19.81				
BDS	= Floor Machine	80	= 21.13				
		150	= 39.63				

**EXAMPLE: KM 70/20 C = SWEEPER, 18.49 GALLONS / 8 INCHES CLEANING PATH / COMPACT**

# EB 30/1

This ultra-quiet and compact sweeper is perfect for quick clean-ups in busy and crowded areas. The rechargeable battery pack ensures safety by eliminating trip hazards. The EB 30/1 is built to handle small cleaning jobs in professional working environments.

- Cordless electric sweeper designed for commercial applications.
- Flexible and professional interim clean-up
- Powerful, rechargeable battery provides for up to 45 minutes of operation on hard surface, and up to 30 minutes on carpet.
- Extremely quiet operation allows for cleaning even during business hours, making it ideal for use in noise sensitive areas
- Optional high-speed battery charger available for complete charging in 50 minutes.



## EB 30/1

TECHNICAL SPECIFICATIONS	
Cleaning path	in 12
Container capacity	in <sup>2</sup> 67
Operating noise level	dBa 56
Battery runtime	min 30-45
Standard battery charge time	hr 1
Weight	lbs 6
Dimensions (LxWxH)	in 10 x 12 x 43

PART NO.	DESCRIPTION
1.545-121.0	EB 30/1, 12 inch, lithium-ion battery-operated sweeper

ACCESSORIES	
PART NO.	DESCRIPTION
■ 6.654-328.0	Lithium-ion battery for EB 30/1
■ 6.654-197.0	Battery charger
■ 4.762-400.0	Cylindrical brush
□ 4.762-401.0	Cylindrical stiff red brush, for hard-wearing surfaces

■ Included   □ Optional

# KM 70/20 C

Speedy sweeping and painless maintenance rolled into one convenient package. This sweeper provides superior sweeping performance in a compact manual push sweeper. It is built to be rugged and durable for long life.

- Cleans paths, sidewalks and warehouses quickly and conveniently
- Main cylindrical brush is driven by both wheels so that it sweeps equally well in either right or left turns
- Rugged metal pinion drive for long life
- Durable design
- Height of cylindrical brush can be easily adjusted in five positions by a knob on the handle



## KM 70/20 C

### TECHNICAL SPECIFICATIONS

Cleaning path / width - main broom	in	19
Cleaning path / width with 1 sb	in	28
Cleaning path / width with 2 sb	in	36
Side broom diameter	in	13
Debris container capacity	gal	11
Practical productivity	sq ft/hr	30,000
Weight	lbs	50.7
Dimensions (LxWxH)	in	51.2 x 30.14 x 40.7

PART NO.	DESCRIPTION
1.517-106.0	KM 70/20 C , twenty eight inch walk-behind sweeper
1.517-107.0	KM 70/20 C 2SB , thirty six inch push sweeper with dual brushes

ACCESSORIES	
PART NO.	DESCRIPTION
<input checked="" type="checkbox"/> 6.966-005.0	Side broom, water-resistant bristles, extremely durable, suitable for all types of surfaces
<input checked="" type="checkbox"/> 6.906-041.0	Main broom, water-resistant bristles, extremely durable, suitable for all types of surfaces
<input checked="" type="checkbox"/> 4.040-772.0	Dust Filter
<input type="checkbox"/> 2.640-908.0	Litter picker—for picking up waste
<input checked="" type="checkbox"/> Included <input type="checkbox"/> Optional	



# KM 70/30 C BP ADV

Fast and efficient for sweeping indoors or outdoors—on hard floor or carpet for those that need to get the job done right the first time. Rely on this sweeper to make quick work of any sweeping needs with its highly productive electronic driven broom. It also features active dust control for optimum air quality. User-friendly features such as an easy adjust broom height and an adjustable handle height make this a popular machine with those who use it.

- Delivers fast, efficient sweeping for hard and soft floor surfaces
- 28 inch cleaning path
- For a wide range of applications indoors and outdoors, with a particularly quiet battery drive system at 69 dBA
- Features Active Dust Control with a separate fan and flat pleated filter for dustless sweeping indoors
- Simple adjustment of the main cylindrical broom and side broom



## KM 70/30 C BP ADV

### TECHNICAL SPECIFICATIONS

Cleaning path / width - main broom	in	19
Cleaning path / width with 1 sb	in	28
Side broom diameter	in	13
Debris container capacity	gal	11
Practical productivity	sq ft/hr	30,800
Operating noise level	dBA	59
Sweeping method	direct / overthrow	direct
Weight	lbs	105.8
Dimensions (LxWxH)	in	48.8 x 28 x 45.2

PART NO.	DESCRIPTION
1.517-218.0	KM 70/30 C BP ADV, twenty eight inch walk-behind sweeper

### ACCESSORIES

PART NO.	DESCRIPTION
■ 6.966-005.0	Side broom, water-resistant bristles, extremely durable, suitable for all types of surfaces
■ 6.906-041.0	Main broom, water-resistant bristles, extremely durable, suitable for all types of surfaces
■ 6.904-367.0	Flat dust filter
□ 2.640-908.0	Litter picker—for picking up waste
□ 5.731-625.0	Filter element - plastic filter, water resistant, washable, saves maintenance costs
□ 6.907-041.0	Standard cylindrical broom - water-resistant universal bristles, extremely durable, suitable for all types of surfaces

■ Included    □ Optional

# KM 75/40 W BP

Big enough to get the job done, but maneuverable to clean congested areas, count on the KM 75/40 W Bp for your sweeping needs. This machine provides the versatility to clean anywhere—carpet or hard floors, indoors or out. We built it to perform day in and day out in the toughest commercial applications.

- Cleans effectively indoors and out for increased versatility
- Self-propelled, 30 inch cleaning path for increased productivity
- Easy to understand controls increase operator effectiveness
- Over throw sweeping system with an easily removed hopper make emptying quick and efficient
- Active dust control system provides better air quality
- Air is vacuumed through a high-efficiency automotive style filter
- Manual filter shaker for easy cleaning and consistent results
- Wet-sweep bypass for cleaning wet surfaces



**KM 75/40 W BP**

TECHNICAL SPECIFICATIONS		
Cleaning path / width - main broom	in	22
Cleaning path / width with 1 sb	in	30
Side broom diameter	in	16.5
Debris container capacity	gal	10.5
Practical productivity	sq ft/hr	36,328
Operating noise level	dBA	64
Sweeping method	direct / overthrow	overthrow
Weight	lbs	172
Dimensions (LxWxH)	in	56 x 30 x 46.5

PART NO.	DESCRIPTION
9.840-739.0	KM 75/40 W Bp, thirty inch walk-behind sweeper

ACCESSORIES	
PART NO.	DESCRIPTION
■ 8.631-173.0	Battery, 12V AGM 70 Ah
■ 8.629-377.0	Automatic shelf charger, 24V, 24A, 115V, standard on AGM models
■ 6.905-626.0	Side Broom, Soft Bristle (standard)
■ 6.906-884.0	Main Broom, water-resistant bristles, extremely durable, suitable for all surfaces
■ 5.731-635.0	Flat pleated filter—plastic filter, water resistant, washable, reduces maintenance costs
□ 6.905-625.0	Side broom, hard for heavy-duty cleaning
□ 6.906-885.0	Main broom, Hard Bristle
□ 6.906-950.0	Anti-Static Rolling Brush
□ 2.641-571.0	Carpet Sweeping Kit (includes fluff filter, anti-static cylindrical brush and triple caster)
□ 6.906-886.0	Main cylindrical broom, soft/natural - specifically designed with natural bristles for sweeping fine dust on smooth indoor floors

■ Included   □ Optional

# KM 85/50 R BP



The KM 85/50 R Bp is a battery-powered ride-on sweeper perfect for confined and congested areas. Its compact design and high maneuverability make cleaning faster than ever in narrow corridors and around sharp corners. It is extremely easy to operate and maintain, and boasts impressive area performance outdoors.

**Efficient filter system**

- Polyester flat pleated filter
- Effective cleaning with dual scraper

**Ergonomic design for enhanced performance and comfort**

- Clear and simple operation for all components
- Easy, tool-free seat adjustment for operator comfort
- Adjustable rotation speed depending on type of dirt
- Drives through door openings as narrow as 36"



**KM 85/50 R BP**

**TECHNICAL SPECIFICATIONS**

<b>Cleaning path/width- main broom</b>	<b>in</b>	24.2
<b>Cleaning path/width with 1 sb</b>	<b>in</b>	33.5
<b>Cleaning path/width with 2 sb</b>	<b>in</b>	41.3
<b>Side broom diameter</b>	<b>in</b>	16.5
<b>Debris container capacity</b>	<b>gal</b>	13.2
<b>Practical productivity - 1 / 2 sb</b>	<b>sq. ft/hr</b>	32,940 / 40,685
<b>Operating noise level</b>	<b>dBA</b>	69
<b>Sweeping method</b>	<b>direct/overthrow</b>	direct
<b>Weight</b>	<b>lbs</b>	555
<b>Dimensions (LxWxH)</b>	<b>in</b>	50 x 35 x 46

**EQUIPMENT**

ORDER NO.	ITEM DESCRIPTION
9.841-453.0	KM 85/50 R Bp Wet, 1 side broom, shelf charger
9.841-454.0	KM 85/50 R Bp AGM, 1 side broom, shelf charger

**ACCESSORIES**

ORDER NO.	ITEM DESCRIPTION
■ 4.762-430.0	Main brush, standard
■ 6.906-132.0	1-side brush, standard
■ 6.435-773.0	Pneumatic tire (1 each)
■ 5.731-585.0	Flat Filter complete
□ 6.435-431.0	Solid rubber non-marking wheel
□ 4.762-442.0	Main brush, soft
□ 4.762-443.0	Main brush, hard
□ 4.762-441.0	Main brush, antistatic
□ 6.905-626.0	Side brush, soft
□ 6.905-625.0	Side brush, hard
□ 2.852-499.0	Carpet cleaning kit
□ 2.852-321.0	Additional left side brush kit
□ 2.852-500.0	Warning beacon
□ 5.035-488.0	Home Base kit (adapter and cable hook)
□ 6.980-077.0	Double Hook (requires 5.035-488.0)
■ Included □ Optional	

# KM 90/60 RBP

Sweep large areas quickly with this highly maneuverable, ride-on sweeper that increase productivity and safety. This machine cleans multiple surfaces, from tough industrial flooring to soft carpet. Its innovative Tact filter cleaning system extends the filter life, saving you money.

## Highly productive sweeping

- Automatic, continuous sweeping
- Overthrow sweeping



### KM 90/60 R BP ADV

TECHNICAL SPECIFICATIONS		
Cleaning path/width- main broom	in	24.2
Cleaning path/width with 1 sb	in	35.4
Cleaning path/width with 2 sb	in	45.3
Side broom diameter	in	16.5
Debris container capacity	gal	16
Practical productivity - 2 sb	sq. ft/hr	47,520
Operating noise level	dBA	69
Sweeping method	direct/overthrow	direct
Weight	lbs	782
Dimensions (LxWxH)	in	64 x 38.5 x 49.5

### EQUIPMENT

ORDER NO.	DESCRIPTION
9.841-246.0	KM 90/60 R Bp Adv, 1SB, 2 x 12V/225 Ah wet batteries, shelf charger
9.841-247.0	KM 90/60 R Bp Adv, 1SB, 2 x 12V/234 Ah AGM batteries, shelf charger
9.841-248.0	KM 90/60 R Bp Adv, 2SB, 2 x 12V/225 Ah wet batteries, shelf charger
9.841-249.0	KM 90/60 R Bp Adv, 2SB, 2 x 12V/234 Ah AGM batteries, shelf charger

### ACCESSORIES

ORDER NO.	DESCRIPTION
■ 4.762-430.0	Main broom
■ 6.906-132.0	Side broom
■ 6.907-519.0	TACT Filter (2 required)
□ 5.035-488.0	Home Base kit (adapter and cable hook)
□ 6.980-078.0	Mop clip (requires 5.035-488.0)
□ 6.980-080.0	Bottle Hook (requires 5.035-488.0)
□ 6.907-023.0	Anti-static rolling brush
□ 4.762-443.0	Main cylindrical brush, hard
□ 4.762-442.0	Main cylindrical brush, soft/natural
□ 6.905-625.0	Side broom, hard for heavy-duty cleaning
□ 2.642-693.0	Side brush kit, left
□ 2.851-334.0	Carpet sweeping kit (includes anti-static rolling brush)
□ 2.642-989.0	Warning beacon revolving signal light
□ 6.414-532.0	Round filter - plastic filter, water-resistant, washable, saves maintenance costs. (Fits previous KM 90/60 R Bp without Tact)
□ 4.762-442.0	Main cylindrical brush, soft/natural—with natural bristles, ideal for sweeping fine dust on smooth surfaces both indoors and outdoors.
□ 8.622-843.0	Battery pack 234 Ah AGM, 3 required

■ Included □ Optional

# PUZZI™ 8/1 C

The handy, compact and powerful Puzzi™ 8/1 C spray extraction cleaner is ideal for small areas and interim cleaning with excellent cleaning results.

- Foot switch makes it easy to turn on and off – no bending required
- Transparent dome lid for easy-to verify operation
- Swivel casters for easy maneuvering
- Lightweight - it can be easily transported
- 8' high-pressure solution and vacuum hose
- Removable dirty water tank



## PUZZI™ 8/1 C

### TECHNICAL SPECIFICATIONS

<b>Solution / recovery capacity</b>	<b>gal</b>	2 / 1.8
<b>Operating noise level</b>	<b>dB</b>	71
<b>Power cord length</b>	<b>ft</b>	33
<b>Vacuum</b>	<b>hp, stage</b>	1.5 hp
<b>Waterlift</b>	<b>in</b>	88
<b>Pump pressure</b>	<b>psi</b>	14.5 - 43.5
<b>Flow rate</b>	<b>gpm</b>	0.26
<b>Weight</b>	<b>lbs</b>	22
<b>Dimensions (LxWxH)</b>	<b>in</b>	22.5 x 13 x 17.3

PART NO.	DESCRIPTION
1.100-228.0	Puzzi™ 8/1 C , 98 inch spray hose with integrated water feed and hand tool

### ACCESSORIES

PART NO.	DESCRIPTION
<input checked="" type="checkbox"/> 6.391-410.0	8-foot hose, complete with couplings
<input checked="" type="checkbox"/> 4.130-116.0	4-inch upholstery hand tool
<input type="checkbox"/> 4.130-127.0	Floor wand, 2-part with aluminum tube
<input type="checkbox"/> 4.130-394.0	Floor wand, quick-action coupling, aluminum tube and metal nozzle
<input type="checkbox"/> 4.762-220.0	Hard surface kit (attaches to 4.130-127.0 & 4.130-394.0 wands)
<input type="checkbox"/> 2.638-778.0	Window cleaning kit with 6.5Ft hose, (requires 2.389-293.0 coupler)
<input type="checkbox"/> 4.130-083.0	Venetian blind kit (requires 6.389-293.0 coupler)
<input type="checkbox"/> 4.130-444.0	Stair cleaning tool, 9-inch
<input type="checkbox"/> 6.391-411.0	13-foot high pressure solution & vacuum hose
<input type="checkbox"/> 4.130-117.0	Stone & hard surface nozzle
<input type="checkbox"/> 4.762-219.0	Hard surface adapter for standard hand tool
<input type="checkbox"/> 4.130-010.0	Crevice nozzle
<input type="checkbox"/> 4.130-007.0	Carpet nozzle set 240 mm

Included    Optional



# CADET™ 7

It is easy to see why the Cadet™ 7 is such a popular extractor. It has proven itself as a reliable, robust machine that deep cleans carpets to like-new. Operator controls are intuitive and ergonomic for hours of pain-free operation.

**Brilliant deep clean**

- Efficiently deep cleans carpet
- Floating vacuum shoe for superior recovery

**Unmatched value**

- The deep cleaning value choice
- Robust design built for reliability

**Easy-to-use**

- No-hose design makes it simple to fill and empty
- Ergonomic design reduces operator fatigue



**CADET 7**

TECHNICAL SPECIFICATIONS			
Cleaning path/width	in		15
Solution/recovery capacity	gal		7/7
Practical productivity	sq. ft/hr		2,100
Operating noise level	dBa		69
Power cord length	ft		50
Vacuum	hp, stage		1.5, 3
Water lift	in		120
Pump pressure	psi		90
Flow rate	gpm		0.57
Weight	lbs		87
Dimensions (L x W x H)	in		41 x 17.5 x 34

**EQUIPMENT**

PART NO.	DESCRIPTION
1.008-022.0	Cadet™ 7, seven gallon carpet extractor

**ACCESSORIES**

PART NO.	DESCRIPTION
<input type="checkbox"/> 9.840-551.0	Air quality MicroFilter™ kit for Clipper™ 12/Admiral™ 8/Cadet™ 7, includes 2 filters and stainless steel bracket
<input type="checkbox"/> 8.623-611.0	One air quality MicroFilter™ refill
<input type="checkbox"/> 8.623-411.0	Power cord

■ Included  Optional

# BRC 30/15

Get acquainted with the faster, simpler solution for small area extraction. The BRC 30/15 C is designed to productively clean carpet with less effort, resulting in time-saving productivity gains. In interest of simplicity this machine requires minimal service. It is lightweight and compact for ease of use and transportability.

Compact deep cleaning solution

- High performance vacuum motor for faster drying time

Extraction is no sweat

- Quiet, lightweight, easy to use
- Designed for minimal service

Portable and mobile

- Large 10 inch non-marking wheels for easy transport and maneuverability
- Fold-down handle for easy transportation in any vehicle



## BRC 30/15 C

### TECHNICAL SPECIFICATIONS

Cleaning path/width	in	10.5
Solution/recovery capacity	gal	4.5/4
Operating noise level	dBA	77
Power cord length	ft	25
Vacuum	hp, stage	1.5, 3
Water lift	in	120
Pump pressure	psi	26
Flow rate	gpm	0.38
Weight	lbs	79
Dimensions (L x W x H)	in	23 x 14 x 28

### EQUIPMENT

PART NO.	DESCRIPTION
1.008-058.0	BRC 30/15 C, 4 gallon carpet extractor

### ACCESSORIES

PART NO.	DESCRIPTION
■ 8.621-604.0	Brush, chevron, 10-inch
■ 8.629-552.0	Brush, extractor, natural bristles
■ 8.631-030.0	Assembly, adapter (1/8"m x 1/4" fpt nipple)
□ 8.629-036.0	Hose and hand tool kit, bag Included
□ 8.600-075.0	Adapter 1/8 to 1/4 quick-disconnect for accessory solution hose

■ Included □ Optional

# CV 300

Kärcher's CV 300 dual-motor upright vacuum is designed to be simultaneously powerful, lightweight and easy to maneuver. Our 1,000 watt vacuum motors pick up more dirt in a single pass than their comparable single-motor counterparts while our patented filtration system filters out particulates and allergens down to 0.3 microns.

- CRI approved for cleaner, healthier carpets
- Indicator lights alert operator to shut down or blockage
- Innovative, articulating head for superior maneuverability
- Ergonomic carrying handle for easy transport
- Powerful dual motor upright vacuum
- High quality three step filtration for optimum air quality



CV 300

## TECHNICAL SPECIFICATIONS

Cleaning path	in	12
Productivity (practical)	ft <sup>2</sup> / hr	3,104
Power cord length	ft	40
Operating noise level	dB(A)	69.5
Air flow rate	cfm	102
Voltage	110V / 220V	110V
Motor	hp	0.24
Debris bag size	qt	3.7
Weight	lbs	17
Dimensions (LxWxH)	in	11 x 12 x 48

PART NO.	DESCRIPTION
1.012-059.0	CV 300, 120V/60 Hz

## ACCESSORIES

PART NO.	DESCRIPTION
■ 8.632-214.0	Filter, exhaust
■ 8.628-477.0	Filter, motor protection
■ 8.630-933.0	Vacuum fan exhaust filter
□ 8.600-495.0	12-Inch replacement double row brush
□ 8.628-479.0	3-Ply filter dust bags, 10-pack
□ 8.633-398.0	Filter bag, package of 10
□ 8.634-975.0	Tool, 20" extension tool
□ 8.632-244.0	Tool, clips for tools, dark gray
□ 8.632-245.0	Tool, crevice tool, dark gray
□ 8.614-100.0	Dusting brush, dark gray
□ 8.614-629.0	Upholstery nozzle, dark gray
□ 8.604-147.0	Vacuum tools kit (crevice nozzle, upholstery nozzle, and mounting clip)

■ Included    □ Optional

# BV VAC PAC™ HEPA SERIES

The BV/VAC PAC™ HEPA series are portable back mounted vacuums great for increasing productivity, efficiency, while saving you money. Breathe easier with HEPA-level filtration standard on these vacuums. They also have an ergonomic harness system, allowing the operator to move around quickly and easily for maximum productivity.



- HEPA filtration is now standard, providing optimum air quality by filtering with 99.9% effectiveness to 0.3 microns
- Vacuum hose is a top-mounted swivel design for left-hand and right-hand operation

		BV 7/1 VAC PAC 6 HEPA	BV 11/1 VAC PAC 10 HEPA
<b>TECHNICAL SPECIFICATIONS</b>			
Vacuum width, floor tool	in	13	13
Vacuum hose length	in	60	60
Power cord length	ft	50	50
Waste container capacity	qt	6	10
Operating noise level	dBA	67	67
Air flow rate	cfm	112	112
Waterlift	in of	104	104
Motor	watts	1,200	1,200
Weight	lbs	10	11
Dimensions (LxWxH)	in	8.5 x 8.8 x 19.8	8.5 x 8.8 x 23.7

PART NO.	DESCRIPTION
1.014-013.0	BV 7/1 VAC PAC 6 HEPA backpack vacuum, 6 qt. (includes hose and tool kit)
1.014-014.0	BV 11/1 VAC PAC 10 HEPA backpack vacuum, 10 qt. (includes hose and tool kit)

ACCESSORIES	
PART NO.	DESCRIPTION
■ 8.628-666.0	Wand, 2 PC Aluminum Double Curve
■ 8.619-894.0	Hose Assembly
■ 8.639-285.0	HEPA pleated filter
■ 8.619-884.0	Cloth bag for VAC PAC™ HEPA 10 / BV 11/1
■ 8.619-885.0	10-quart paper bags, 10-pack for BV 11/1
■ 8.619-891.0	Paper bags for VAC PAC™ HEPA 6 / BV 7/1
■ 8.619-890.0	Cloth bags for VAC PAC™ HEPA 6 / BV 7/1
■ 8.619-887.0	Filter Dome
■ 8.604-141.0	VAC PAC™ tool kit (#02293 crevice tool, #02083 dusting brush, #02084 upholstery tool, #02085 upholstery tool brush, #02086 extension tube)
<input type="checkbox"/> 8.628-451.0	Crevice Tool
<input type="checkbox"/> 8.600-008.0	5' Upholstery Tool
<input type="checkbox"/> 8.628-360.0	Upholstery Brush
<input type="checkbox"/> 8.600-007.0	3-inch dusting tool with adapter
<input type="checkbox"/> 8.628-445.0	Tool, Carpet
<input type="checkbox"/> 8.628-444.0	Tool, bristle shod dry pick-up
<input type="checkbox"/> 8.619-876.0	VAC PAC™ Crevice Tool
<input type="checkbox"/> 8.631-254.0	Harness assembly for VAC PAC™ HEPA 6 & 10 and BV 11/1
<input type="checkbox"/> 8.642-914.0	15" sidewinder carpet tool with 1.5" neck
<input type="checkbox"/> 8.642-915.0	15" sidewinder hard floor brush with 1.5" neck
<input type="checkbox"/> 8.642-916.0	18" sidewinder carpet tool with 1.5" neck
<input type="checkbox"/> 8.642-917.0	18" sidewinder hard floor brush with 1.5" neck

■ Included     Optional

# NT 25/1 AP

The NT 25/1 AP delivers powerful wet/dry cleaning in one compact package. This mobile all-purpose vacuum is easy and comfortable to transport to any job site. Designed for function, our vacuum features a light weight construction. Enjoy knowing that you can pick up anything wet or dry with this handy, practical machine.

- Comfortable and easy to handle and includes on-board accessory storage
- Five caster wheel design provides superior movement and stability
- Complete accessory holder and cord hook
- Convenient additional storage area on the turbine head
- Mobile and lightweight, perfect for transport to multiple locations
- Easy, safe and quickly exchangeable clip hose connections
- Ergonomically designed hose for operator comfort



## NT 25/1 AP

### TECHNICAL SPECIFICATIONS

Vacuum width, floor tool	in	11
Vacuum hose length	ft	8
Power cord length	ft	25
Waste container capacity	gal	6.6
Operating noise level	dB(A)	70
Air flow rate	cfm	123
Waterlift	in of water	88
Motor	watts	1,170
Weight	lbs	24
Dimensions (LxWxH)	in	20 x 14.5 x 19

PART NO.	DESCRIPTION
1.184-868.0	NT 25/1 AP, 6.6 gallon wet / dry vacuum

### ACCESSORIES

PART NO.	DESCRIPTION
■ 4.440-626.0	Suction hose C DN35
■ 6.906-240.0	Crevice nozzle DN35
■ 6.903-284.0	Floor tool DN35
■ 6.900-514.0	Suction tube DN35
■ 6.907-478.0	Set of filter bags - fleece 25L

- Included     Optional



# NT 22/1 AP

The NT 22/1 Ap Bp is the first wet/dry vac in the market that offers professional suction performance in a battery machine. It has the same air flow as the equivalent corded machine – unprecedented for the cleaning and power tool industry. Its compact design and low weight make it the ideal wet and dry vac for all mobile applications. Whether for BSC customers, in hotels, retail outlets, in the commercial cleaning business or for craftsmen: this machine offers unlimited mobility since users can now do their work independent of power socket availability.

- Equipped with powerful 36V, 7.5 Ah Battery Power+ battery and fast charger - only 50-80 minutes to a full charge
- Low weight and compact dimensions for outstanding mobility
- Semi-automatic filter cleaning system for uninterrupted working
- Flat pleated filter guarantees high usable container volume
- Dust class L certification (99.0% efficiency)



## NT 22/1

### TECHNICAL SPECIFICATIONS

Vacuum width, floor tool	in	12
Vacuum hose length	ft	6.2
Power cord length	ft	31
Waste container capacity	gal	5.8
Operating noise level	dB(A)	71
Air flow rate	cfm	121
Waterlift	in of water	61
Motor	watts	19.4
Weight	lbs	16 x 15 x 20
Dimensions (LxWxH)	in	22 x 14.5 x 22.2

PART NO.	DESCRIPTION
1.528-128.0	NT 22/1 Ap Bp

ACCESSORIES	
PART NO.	DESCRIPTION
■ 2.445-053.0	Battery+ 36/75
■ 2.445-075.0	Fast battery charger
■ 6.904-156.0	Flat pleated filter
■ 6.907-469.0	Fleece filter bag - pack of 5 (1 included with machine)
■ 2.889-263.0	Floor tool
■ 2.889-218.0	Suction tube set
■ 2.889-159.0	Crevice nozzle
■ 2.889-199.0	Elbow
□ 2.889-134.0	Vacuum hose, 8.2 feet (6.2 ft hose not sold separately)

■ Included    □ Optional

# NT 30/1 TACT TE

This powerful vacuum cleaner picks up coarse dirt and liquids as well as large quantities of fine dust. Tact, the fully automatic cleaning system, cleans the filter with strong air blasts. It is ideal for long periods of uninterrupted use and constant high suction power.

- Blasts of air clean the filter resulting in lower maintenance costs and a longer filter life ultimately saving you money
- On-board storage for all accessories, includes two hooks for the suction hose and power cord
- Bayonet and clip connections guarantee easy and secure connection of all accessory parts onto machine
- HEPA filter is standard



## NT 30/1 TACT TE

### TECHNICAL SPECIFICATIONS

Vacuum width, floor tool	in	14
Vacuum hose length	ft	13
Power cord length	ft	25
Waste container capacity	gal	8.2
Operating noise level	dBA	68
Air flow rate	cfm	150
Waterlift	in of water	102
Motor	watts	1,380
Weight	lbs	30
Dimensions (LxWxH)	in	22 x 14.5 x 22.2

PART NO.	DESCRIPTION
1.148-216.0	NT 30/1 Tact TE , 8-gallon wet/dry vacuum with Tact

### ACCESSORIES

PART NO.	DESCRIPTION
■ 2.889-192.0	Stainless steel vacuum tube set
■ 2.889-135.0	Vacuum hose 13 ft
■ 2.889-134.0	Vacuum hose 8 ft
■ 2.889-170.0	Ergonomic bend
■ 2.889-152.0	Wet and dry floor nozzle
■ 2.889-159.0	Crevice nozzle
■ 2.889-151.0	Power tool adaptor
■ 2.889-154.0	Fleece filter bags - 30 liter
■ 6.907-629.0	HEPA filter

■ Included    □ Optional

# NT 30/1 ACCESSORIES



PART NO.	DESCRIPTION
<input type="checkbox"/> 2.889-137.0	Vacuum hose 1-3/8 inch diameter (DN 35) 13 ft electrically conductive
<input type="checkbox"/> 2.889-136.0	Vacuum hose 1-3/8 inch diameter (DN 35) 8 ft electrically conductive
<input type="checkbox"/> 2.889-164.0	Vacuum hose 1-3/8 inch diameter (DN 35) 8 ft heat-resistant
<input type="checkbox"/> 2.889-172.0	Ergonomic bend 1-3/8 inch diameter (Dn 35) with soft grip electrically conductive
<input type="checkbox"/> 2.889-148.0	Ergonomic bend 1-3/8 inch diameter (DN 35) with soft grip and vacuum power regulation
<input type="checkbox"/> 6.907-455.0	Flat pleated filter PTFE
<input type="checkbox"/> 2.679-000.0	Drilling dust nozzle 1-3/8 inch diameter (DN 35)
<input type="checkbox"/> 2.889-138.0	Vacuum hose 1-5/8 inch diameter (DN 40), 13 ft
<input type="checkbox"/> 2.889-139.0	Vacuum hose 1-5/8 inch diameter (DN 40), 8 ft
<input type="checkbox"/> 2.889-141.0	Vacuum hose 1-5/8 inch diameter (DN 40), 13 ft electrically conductive
<input type="checkbox"/> 2.889-140.0	Vacuum hose 1-5/8 inch diameter (DN 40), 13 ft oil-resistant
<input type="checkbox"/> 2.889-171.0	Ergonomic bend 1-5/8 inch diameter (DN 40), with soft grip
<input type="checkbox"/> 2.889-172.0	Ergonomic bend 1-5/8 inch diameter (DN 40), with soft grip electrically conductive
<input type="checkbox"/> 2.889-194.0	Set of vacuum tubes 1-5/8 inch diameter (DN 40), 2 x 1.8 ft, stainless steel
<input type="checkbox"/> 6.907-629.0	HEPA filter for NT 30/1, NT 40/1 and NT 50/1
<input type="checkbox"/> 5.453-042.0	<b>(Photo 1 above)</b> Power tool adapter, fits these size shrouds: 1.06" – 1.10" OD, 1.25" – 1.32" OD, 1.37" – 1.44" OD, 1.47" – 1.50" OD
<input type="checkbox"/> 5.453-016.0	<b>(Photo 2 above)</b> Power tool adapter, fits these size shrouds: 1.06" – 1.07" OD, 1.27" – 1.30" OD, 1.40" – 1.41" OD
<input type="checkbox"/> 5.407-108.0	<b>(Photo 3 above)</b> Power tool adapter: connects to 40mm hose connection, screws into 35mm hose or 5.453-016.0 tool adapter
<input type="checkbox"/> 2.637-217.0	<b>(Photo 4 above)</b> Power tool "Y" adapter
<input type="checkbox"/> 5.453-085.0	<b>(Photo 5 above)</b> Power tool adapter sleeve 40 x 50 mm
<input type="checkbox"/> 5.407-113.0	<b>(Photo 6 above)</b> Reducer, DN 40 to DN 35 hose connection
<input type="checkbox"/> 5.031-703.0	Tension ring (order with 5.407-113.0)

■ Included    □ Optional

# NT 48/1

Built to handle difficult wet or dry dirt, this vac is the machine that will stand up to tough everyday use. The optional front mounted squeegee provides even more productive water pickup. It is easy to transport from site to site with its large rear wheels and front casters as well as an easy to grip handle. The large filter provides impressive suction power and long work intervals improving your productivity.



- Mobile, all-purpose wet / dry vacuum for small to medium jobs and multiple locations
- Integrated handle ensures easy and comfortable transport
- Optional front mounted squeegee for more productive pickup

**NT 48/1**

**TECHNICAL SPECIFICATIONS**

<b>Vacuum width, floor tool</b>	<b>in</b> 12	<b>Air flow rate</b>	<b>cfm</b> 142
<b>Vacuum hose length</b>	<b>ft</b> 8	<b>Waterlift</b>	<b>in of water</b> 80
<b>Power cord length</b>	<b>ft</b> 25	<b>Motor</b>	<b>watts</b> 1,380
<b>Waste container capacity</b>	<b>gal</b> 12	<b>Weight</b>	<b>lbs</b> 22
<b>Operating noise level</b>	<b>dBA</b> 72	<b>Dimensions (LxWxH)</b>	<b>in</b> 19 x 15.3 x 30.3

PART NO.	DESCRIPTION
1.428-623.0	NT 48/1, 13-gallon wet/dry vacuum
9.840-844.0	NT 48/1, 13-gallon wet/dry vacuum with front mounted squeegee

**ACCESSORIES**

PART NO.	DESCRIPTION
■ 6.414-789.0	Cylindrical Dust Filter
■ 6.904-285.0	Paper filter bag (5-pack, 1 bag Included with machine)
■ 6.906-512.0	All-Purpose Nozzle
■ 6.900-385.0	8.3-inch all purpose crevice nozzle
■ 4.440-626.0	8 feet x 1.375 inch hose with comfortable hand grip
■ 6.900-514.0	Metal suction tube, 1.4 inch X 1.6 feet
■ 6.906-240.0	Crevice nozzle, 1.4-inch
□ 6.904-211.0	Wet Filter Bag
□ 6.906-384.0	14.6" Aluminum All-Purpose Nozzle with Height-Adjustable Cylindricals, Brush Strips and Oil Resistant Squeegees
□ 6.907-409.0	Floor tool packaged basalt grey DN35
□ 6.907-408.0	Floor tool packaged basalt grey DN40
□ 6.906-383.0	17.7" Aluminum All-Purpose Head with Height-Adjustable cylindricals, Brush Stripes and oil-resistant Squeegees
□ 2.860-113.0	Upholstery hand tool
□ 2.860-114.0	10-inch turbo nozzle with reducer 35/32
□ 6.903-033.0	11.4" Crevice Tool
□ 6.905-998.0	Upholstery nozzle complete NW35
□ 6.903-034.0	Radiator Brush for use with 6.900-385.0
□ 6.903-035.0	Plastic, Pipe Diameter 3.9"
□ 6.903-862.0	Suction Brush, Natural Hair, Pivotable, 35 mm ID
□ 2.860-116.0	Nozzle Set, Crevice Tool, Upholstery Tool, Round Brush, 35 mm ID
□ 2.863-147.0	All-Purpose Brush, Soft Bristles 35 mm ID
□ 8.622-960.0	Replacement 15-inch squeegee blade

- Included    □ Optional

# NT 68/1

Easily tackle medium to large jobs with this wet/dry vac. Designed with a robust 1.8 hp vac motor to handle any task you throw at it. If even more productivity is desired, the optional front mounted squeegee makes quick work of water recovery. Thoughtful features such as no-tipping dumping and on-board storage make this the operator's choice for wet/dry vacs.

- Optional front-mounted squeegee offers more productive water pick-up
- 18 gallon capacity offers easy mobility for medium to large jobs
- Easy to use, train and operate
- Complete with on-board tool storage compartment with safety sign storage bracket
- Self-adjusting squeegee assembly



NT 68/1

## TECHNICAL SPECIFICATIONS

Vacuum width, floor tool	in	24.5
Power cord length	ft	50
Waste container capacity	gal	18
Operating noise level	dB(A)	71
Air flow rate	cfm	142
Waterlift	in of	80
Motor	watts	1,200
Weight	lbs	64
Dimensions (LxWxH)	in	35.5 x 24.5 x 37.5

PART NO.	DESCRIPTION
1.103-494.0	NT 68/1, eighteen gallon wet/dry vacuum with 24" front squeegee, with tools
1.103-495.0	NT 68/1, eighteen gallon wet/dry vacuum with 24" front squeegee
1.013-021.0	NT 68/1, eighteen gallon wet/dry vacuum with hose and wand only

## ACCESSORIES

PART NO.	DESCRIPTION
<input type="checkbox"/> 5.731-595.0	Wet Filter for Recover™ 18
<input type="checkbox"/> 6.414-552.0	Cartridge Filter (Dry)
<input type="checkbox"/> 5.731-595.0	Cartridge Filter (Wet)
<input type="checkbox"/> 6.900-385.0	8.3-inch all purpose crevice nozzle
<input type="checkbox"/> 6.906-240.0	Crevice nozzle, 1.4-inch
<input type="checkbox"/> 6.906-384.0	14.6" Aluminum All-Purpose Nozzle with Height-Adjustable Cylindricals, Brush Strips and Oil Resistant Squeegees
<input type="checkbox"/> 6.907-409.0	Floor tool packaged basalt grey DN35
<input type="checkbox"/> 6.903-018.0	14.6" Aluminum All-Purpose Head with Height-Adjustable Cylindricals, Brush Stripes and squeegee blades
<input type="checkbox"/> 6.907-408.0	Floor tool packaged basalt grey DN40
<input type="checkbox"/> 6.906-383.0	17.7" Aluminum all-purpose head with height-adjustable cylindricals, brush stripes and oil-resistant Squeegees
<input type="checkbox"/> 2.860-113.0	Upholstery hand tool
<input type="checkbox"/> 2.860-114.0	10-inch turbo nozzle with reducer 35/32
<input type="checkbox"/> 6.903-033.0	11.4" Crevice Tool
<input type="checkbox"/> 6.900-922.0	14.6" Crevice Nozzle, Metal
<input type="checkbox"/> 6.902-154.0	Wand
<input type="checkbox"/> 8.635-292.0	Front mount squeegee assembly
<input type="checkbox"/> 6.906-512.0	Squeegee head

■ Included     Optional



# BR 35/12 C BP

Thanks to our innovative steerable scrub deck, the BR 35/12 C Bp can clean up to the wall at a 90° angle. It can also clean in reverse, or in any direction. The height-adjustable, telescoping steering column allows optimal ergonomics for any operator. The folding steering column also makes it easy to secure for transport.

- *Steerable scrub deck allows for scrubbing in any direction and provides perfect scrubbing right up to the edge*
- *The telescoping handle adjusts to any operator's height*
- *Brush height is adjustable for multiple floor types*
- *Eco!efficiency mode increases operating time by 50%, and reduces noise by 40%*



BR 35/12 C BP

**TECHNICAL SPECIFICATIONS**

Cleaning path / width	in	14	Battery runtime	min	66-90
Brush type	cylindrical / disc / pad	Cylindrical	Battery charging time	hrs	1-3
Brush quantity	units	1	Battery lifetime - est charging cycle	x thousands	3
Brush diameter	in	3.8	Brush contact pressure	lbs	29
Suction bar (squeegee) width	in	18	Brush speed	rpm	700-1,050
Drive	pad-assist / traction	Brush-assist	Vac motor rating	watts	280
Solution / recovery capacity	gal	3 / 3	Vac motor suction	cfm	42
Theoretical / practical productivity	sq. ft / hr	11,000 / 6,600	Waterlift	in of water	32
Operating noise leve - std Eco! mode	dBA	66 / 62	Weight with batteries	lbs	77
Battery charger	shelf / on-board	On-board	Dimensions (LxWxH)	in	39 x 18 x 51

PART NO.	DESCRIPTION
1.783-470.0	BR 35/12 C BP, fourteen inch scrubber with cylindrical brushes

**ACCESSORIES**

PART NO.	DESCRIPTION
■ 4.037-031.0	Cylindrical Brush, red, medium
■ 4.037-035.0	Squeegee blade set, standard, oil-resistant, polyurethane
■ 6.654-294.0	Lithium-ion battery, 21 Ah
□ 4.037-036.0	Cylindrical Brush, white, soft
□ 4.037-037.0	Cylindrical Brush, orange, high/low
□ 4.037-038.0	Cylindrical Brush, green, hard
□ 4.037-039.0	Cylindrical Brush, black, very hard
□ 4.762-009.0	Cylindrical Pad cylindrical shaft
□ 6.369-053.0	Cylindrical Pads on sleeve, yellow, soft
□ 6.369-047.0	Cylindrical Pads on sleeve, red, medium
□ 6.369-052.0	Cylindrical Pads on sleeve, green, hard
□ 4.037-040.0	Cylindrical microfiber pad, for daily cleaning of delicate surfaces including LVT and stone tile

■ Included □ Optional

# BD 38/12 C BP

Think of the BD 38/12 as a 15 inch disc version of the popular BR 35/12. The design allows for the easiest driving of a walk-behind disk scrubber on the market. The squeegee follows behind the disc to ensure 100% solution pickup even through the corners.

- Agile for efficient cleaning of small and furnished areas
- Easy to use — scrub right up to the wall
- Quick charging lithium-ion battery
- Very compact, light and easy to transport and roll over steps.
- Reduced operating noise level for noise sensitive areas



BD 38/12 C BP

## TECHNICAL SPECIFICATIONS

Cleaning path / width	in	15	Battery runtime	min	60-120
Brush type	cylindrical / disc / pad	Disc	Battery charging time	hrs	2-3
Brush quantity	units	1	Battery lifetime - est charging cycles	x thousands	3
Brush diameter	in	15	Brush contact pressure	lbs	35-46
Suction bar (squeegee) width	in	16	Brush speed	rpm	180 / 150
Drive	pad-assist / traction	Brush-assist	Vac motor rating	watts	280
Solution / recovery capacity	gal	3.2 / 3.2	Vac motor suction	cfm	42
Theoretical / practical productivity	sq. ft / hr	11,210 / 6,725	Waterlift	in of water	32
Operating noise leve - std / Eco! mode	dBa	65 / 62	Weight with batteries	lbs	79
Battery charger	shelf / on-board	On-board	Dimensions (LxWxH)	in	37 x 30 x 51

PART NO.	DESCRIPTION
1.783-431.0	BD 38/12 C, compact scrubber with fifteen inch disc brush

## ACCESSORIES

PART NO.	DESCRIPTION
■ 6.907-151.0	Disc brush, red
■ 6.654-294.0	Lithium-ion battery, 21 Ah
■ 4.037-059.0	Squeegee blades, made from transparent and oil-resistant polyurethane, includes front and rear blade
□ 6.907-150.0	Pad driver plate
□ 6.369-003.0	Red disc pads, set of 5
□ 6.369-002.0	Green disc pads, medium soft, green, set of 5
□ 6.369-001.0	Black disc pads, hard, set of 5
□ 6.905-060.0	Disc microfiber pad, for daily cleaning of delicate surfaces including LVT and stone tile, set of 5

■ Included □ Optional

# BD 50/50 C CLASSIC BP

This economically-designed scrubber provides you all the cleaning power to take on large jobs—perfect for retail environments, schools and health care facilities.

- Three cleaning modes for any operator to get the job done right
- The slim design allows you to see in front of the scrubber easier
- Home Base kit allows for carrying essentials on the machines



BD 50/50 C CLASSIC BP

## TECHNICAL SPECIFICATIONS

Cleaning path / width	in	20	Battery charger	shelf / on-board	Shelf
Brush type	cylindrical / disc / pad	Pad	Brush contact pressure	lbs	59-62
Brush quantity	units	1	Brush speed	rpm	180
Brush diameter	in	20	Vac motor rating	watts	500
Suction bar (squeegee) width	in	33	Vac motor suction	cfm	51
Drive	pad-assist / traction	Pad-assist	Waterlift	in of water	48
Solution / recovery capacity	gal	13.2 / 13.2	Weight with batteries	lbs	306
Theoretical / practical productivity	sq. ft / hr	21,530/13,995	Dimensions (LxWxH)	in	47 x 21 x 39
Operating noise leve - std / Eco! mode	dBA	66			

PART NO.	DESCRIPTION
1.127-029.0	BD 50/50 C Classic Bp, pad driver, 24V/105 Ah wet batteries
1.127-030.0	BD 50/50 C Classic Bp, pad driver, 24V/100 Ah AGM batteries

## ACCESSORIES

PART NO.	DESCRIPTION
■ 4.762-534.0	Pad driver, 20 inch, features a quick-change coupling and centerlock
■ 4.777-179.0	V-Shaped squeegee, 900 mm, with caster, polyurethane
<input type="checkbox"/> 6.273-023.0	Replacement Blades V-Shaped Squeegee 1010mm
<input type="checkbox"/> 4.905-029.0	Brush, hard black - For stubborn dirt and basic cleaning. For hard wearing surfaces.
<input type="checkbox"/> 4.905-026.0	Disc brush, medium grit, red, for general cleaning (standard on brush machines)
<input type="checkbox"/> 6.369-079.0	Red disc pad, 20-inch, medium soft red for cleaning all types of floors, 5-pack
<input type="checkbox"/> 6.369-078.0	Green disc pad, 20-inch, aggressive for cleaning heavily soiled floors and for deep cleaning, 5-pack
<input type="checkbox"/> 6.369-077.0	Black pad, 20-inch, hard, for cleaning heavily soiled floors and for deep cleaning, 5 pack
<input type="checkbox"/> 6.369-468.0	Beige disc pad, 20-inch, light grit, for polishing and refreshing of hard and elastic smooth floor coverings, 5 pack
<input type="checkbox"/> 4.777-179.0	Suction bar v-shaped 900mm CN
<input type="checkbox"/> 6.273-023.0	Rubber lip set corrugated oil resistant
<input type="checkbox"/> 6.371-146.0	Beige disc pad, 20 inch, soft, natural hair, for polishing
<input type="checkbox"/> 4.777-401.0	Squeegee, 33.5 inch, straight, made of oil-resistant transparent polyurethane, for smooth floors
<input type="checkbox"/> 5.035-488.0	Home Base kit (adapter and cable hook)
<input type="checkbox"/> 6.980-077.0	Double Hook (requires 5.035-488.0)
<input type="checkbox"/> 4.035-406.0	Home Base kit carrying case
<input type="checkbox"/> 6.980-078.0	Mop clip (requires 5.035-488.0)
<input type="checkbox"/> 6.980-080.0	Bottle Hook (requires 5.035-488.0)
<input type="checkbox"/> 4.070-075.0	Universal hook
<input type="checkbox"/> 8.641-483.0	Charger for wet batteries
<input type="checkbox"/> 8.629-377.0	Charger for AGM batteries

■ Included     Optional

# B 40 W BP

We built this machine to be easy to operate, safe and easy to maintain. Our Kärcher Intelligent Key (KiK) and our advanced EASY operation are some of the many reasons why the B 40 C/W family offers a full spectrum of safety and protection for operators, machines and your floors.

- 100% control of the speed of your scrub brushes allows you to balance scrubbing power, noise levels and power consumption
- Choose disc and cylindrical decks from 17 to 22 inches
- Decks can be changed quickly and without tools
- The B 40 has six different cleaning modes so you can easily adjust the machine to fit your needs



		B 40 W DISC	B 40 W CYLINDRICAL
<b>TECHNICAL SPECIFICATIONS</b>			
Cleaning path / width	in	17-20	18-22
Brush type	cylindrical / disc / pad	disc	cylindrical
Brush quantity	units	1	2
Brush diameter	in	17-20	3.75
Suction bar (squeegee) width	in	33.5	33.5
Drive	pad-assist / traction	traction	traction
Solution / recovery capacity	gal	10.6 / 10.6	10.6 / 10.6
Theoretical productivity	sq. ft / hr	17,200-21,530	18,210-23,680
Operating noise level - std / Eco! mode	dB(A)	69-60	69-60
Battery charger	shelf / on-board	on-board	on-board
Brush contact pressure	lbs	135-160	80-86
Brush speed	rpm	180	1,200
Drive / vac motor rating	watts	130 / 500	130 / 500
Vac motor suction	cfm	47	47
Waterlift	in of water	48	48
Weight with batteries	lbs	307-384	307-384

PART NO.	DESCRIPTION
9.841-122.0	B 40 W BP, traction drive, scrub deck sold separately, 24V/105 Ah batteries
9.841-123.0	B 40 W BP, traction drive, scrub deck sold separately, 24V/138 Ah AGM batteries
9.841-372.0	B 40 W BP, traction drive, R 55 cylindrical scrub deck, 24V/105 Ah wet batteries
9.841-373.0	B 40 W BP, traction drive, D 51 disc scrub deck, 24V/105 Ah batteries
9.841-374.0	B 40 W BP, traction drive, R 55 cylindrical scrub deck, 24V/138 Ah AGM batteries
9.841-375.0	B 40 W BP, traction drive, D 51 disc scrub deck, 24V/138 Ah AGM batteries

# B 40 C/W BP ACCESSORIES

## ACCESSORIES

PART NO.	DESCRIPTION
■ 4.777-411.0	Curved squeegee assembly, 33.5 inches, with caster, polyurethane
■ 5.035-488.0	Home Base kit (adapter and cable hook)
■ 6.980-077.0	Double hook (requires 5.035-488.0)
■ 5.035-344.0	Operator key, yellow
■ 5.035-348.0	Foreman key, gray
□ 4.035-369.0	Lid with tank rinsing system
□ 4.035-345.0	Quick fill tank system (requires 9.083-003.0)
□ 9.083-003.0	Hose coupling
□ 6.273-207.0	Squeegee blade set, oil resistant (standard w/ 4.777-411.0)
□ 6.273-229.0	Squeegee blade set, anti stripe oil resistant
□ 6.273-290.0	Squeegee blade set, for textured floors
□ 6.273-213.0	Squeegee blade set, EPDM
□ 4.777-401.0	Squeegee assembly with straight polyurethane reversible blades
□ 4.777-406.0	Squeegee assembly with straight EPDM blades
□ 4.777-416.0	Squeegee assembly with curved EPDM blades
□ 4.035-374.0	Home Base kit (includes mop support, mop clip and bottlehook)
□ 4.035-406.0	Home Base kit carrying case
□ 5.035-655.0	Plate mop bracket
□ 6.980-078.0	Mopclip (requires 5.035-488.0)
□ 5.035-488.0	Mop support
□ 5.035-656.0	Mop bracket (for mop support 5.035-655.0)
□ 6.980-080.0	Bottle hook (requires 5.035-488.0)
□ 4.035-408.0	Operator key, yellow, set of 5

■ Included □ Optional

## SERVICES

PART NO.	DESCRIPTION
□ 7.000-270.0	Fleet one year premium subscription



# B 60 W BP

The B 60 W Bp is the walk-behind scrubber built for efficiency from the ground up. Accomplish more with the same size staff with the impressive productivity of this machine. Choose between cylindrical, disc or oscillating mechanics and various widths to suit your needs with our interchangeable scrub decks. Tailor your operation settings with our innovative KiK key system.



- 100% control of the speed of your scrub brushes allows you to balance scrubbing power, noise levels and power consumption
- Choose disc, cylindrical, or oscillating decks from 22-26 inches
- Each can be changed quickly and without tools



		B 60 W + R 55	B 60 W + D 55	B 60 W + R 65	B 60 W + D 65	B 60 W + S 65
<b>TECHNICAL SPECIFICATIONS</b>						
Cleaning path / width	in	22	22	26	26	26
Brush type	cylindrical / disc / pad	cylindrical	disc	cylindrical	disc	oscillating
Brush quantity	units	2	1	2	2	1
Suction bar (squeegee) width	in	33.5	33.5	39	39	33.5
Drive	pad-assist / traction	traction	traction	traction	traction	traction
Solution / recovery capacity	gal	16 / 16	16 / 16	16 / 16	16 / 16	16 / 16
Theoretical / practical productivity	sq. ft / hr	23,680 / 15,390	23,680 / 15,390	27,980 / 18,180	27,980 / 18,180	23,680 / 15,390
Operating noise level	dBA	66-61	66-61	66-61	66-61	66-61
Battery charger	shelf / on-board	on-board	on-board	on-board	on-board	on-board
Brush contact pressure	lbs	193	92	193	95	78
Brush speed	rpm	600-1300	180	600-1300	180	2000
Drive / vac motor rating	watts	300 / 580	300 / 580	300 / 580	300 / 580	300 / 580
Vac motor suction	cfm	47	47	47	47	47
Waterlift	in of water	67	67	67	67	67
Weight with batteries	lbs	400	360	425	400	430

PART NO.	DESCRIPTION
9.841-387.0	B 60 W BP, D 65 disc scrub deck, 24V/230 Ah AGM batteries
9.841-173.0	B 60 W BP, R 65 cylindrical scrub deck, 24V/230 Ah AGM batteries, on-board charger
9.841-175.0	B 60 W BP, S 65 oscillating scrub deck, 24V/230 Ah AGM batteries, on-board charger

# B 60 W BP ACCESSORIES

## ACCESSORIES

PART NO.	DESCRIPTION
■ 4.777-080.0	Squeegee assembly, 37-inch, V-shaped polyurethane oil-resistant blades, standard on machines with R 65 & D 65 scrub decks
■ 5.035-488.0	Home Base kit (adapter and cable hook)
■ 6.980-077.0	Double hook (requires 5.035-488.0)
□ 4.035-386.0	Lid with tank rinsing system
□ 4.035-345.0	Quick fill tank system (requires 9.083-003.0)
□ 9.083-003.0	Hose coupling
□ 6.273-214.0	Squeegee blade set, blue EPDM
□ 6.273-208.0	Squeegee blade set, oil resistant (standard w/ 4.777-412.0)
□ 6.273-205.0	Squeegee blade set, anti stripe oil resistant
□ 6.273-291.0	Squeegee blade set, for textured floors
□ 4.035-472.0	New connection element for cylindrical brush heads, B 60 W
□ 4.035-473.0	Accessory kit to use on B 60 head
□ 4.035-408.0	KIK Key

■ Included □ Optional

## SERVICES

PART NO.	DESCRIPTION
□ 7.000-270.0	Fleet one year premium subscription

# B 80 W BP

The B 80 W BP scrubbers cover a lot of area quickly, but are still easily maneuverable. They feature a robust, interchangeable, maintenance-friendly scrub deck. Choose from cylindrical or disc in 22", 26", or 30" widths. Kärcher Fleet comes pre-installed on this machine to provide you with complete visibility of your machine.

- Decks automatically raise and lower as necessary
- Interchangeable decks can be changed quickly and without tools
- Easily select your cleaning mode with the easy-to-read symbols on the large 4-color display



		B 80 W + R 65	B 80 W + R 75	B 80 W + D 65	B 80 W + D 75
<b>TECHNICAL SPECIFICATIONS</b>					
Cleaning path / width	in	26	30	26	30
Brush type	<b>cylindrical / disc / pad</b>	cylindrical	cylindrical	disc	disc
Brush quantity	<b>units</b>	2	2	2	2
Suction bar (squeegee) width	in	39	39	39	39
Drive	<b>pad-assist / traction</b>	traction	traction	traction	traction
Solution / recovery capacity	gal	21 / 21	21 / 21	21 / 21	21 / 21
Theoretical / practical productivity	sq. ft / hr	27,980 / 18,180	32,290 / 21,000	27,980 / 18,180	32,290 / 21,000
Operating noise level	dBA	69 - 66	69 - 66	69 - 66	69 - 66
Battery charger	<b>shelf / on-board</b>	on-board	on-board	on-board	on-board
Brush contact pressure	lbs	213	213	117	136
Brush speed	rpm	400-1,550	400-1,550	180	180
Drive / vac motor rating	watts	350 / 580	350 / 580	350 / 580	350 / 580
Vac motor suction	cfm	53	53	53	53
Waterlift	<b>in of water</b>	67	67	67	67
Weight with batteries	lbs	282 / 617	284 / 617	289 / 617	293 / 617
Dimensions (LxWxH)	in	61 x 29 x 45	61 x 32 x 45	62 x 29 x 45	64 x 32 x 45

PART NO.	DESCRIPTION
9.841-197.0	B 80 W Bp, scrub deck sold separately, 24V/225 Ah wet batteries, on-board charger, with curved squeegee
9.841-202.0	B 80 W Bp, scrub deck sold separately, 24V/260 Ah wet batteries, on-board charger, with curved squeegee
9.841-196.0	B 80 W Bp, D 65 disc scrub deck, batteries and charger sold separately, with curved squeegee
9.841-195.0	B 80 W Bp, R 65 cylindrical scrub deck, batteries and charger sold separately, with curved squeegee
9.841-199.0	B 80 W Bp, Scrub deck sold separately, 24V/255 Ah AGM batteries, on-board charger, with curved squeegee
9.841-388.0	B 80 W Bp, D 65 disc scrub deck, 24V/225 Ah wet batteries
9.841-204.0	B 80 W Bp, D 65 disc scrub deck, 24V/260 Ah wet batteries, with curved squeegee
9.841-198.0	B 80 W Bp, R 65 cylindrical scrub deck, 24V/225 Ah wet batteries, on-board charger, with curved squeegee
9.841-200.0	B 80 W Bp, R 65 cylindrical scrub deck, 24V/255 Ah AGM batteries, on-board charger, with curved squeegee
9.841-201.0	B 80 W Bp, D 65 disc scrub deck, 24V/255 Ah AGM batteries, on-board charger, with curved squeegee
9.841-203.0	B 80 W Bp, R 65 cylindrical scrub deck, 24V/260 Ah wet batteries, on-board charger, with curved squeegee

# B 80 W BP ACCESSORIES

## ACCESSORIES

PART NO.	DESCRIPTION
■ 4.777-412.0	Squeegee assembly, 37-inch, v-shaped polyurethane oil-resistant blades, standard on machines with R 75 & D 75 scrub decks
■ 5.035-488.0	Home Base kit (adapter and cable hook)
■ 6.980-077.0	Double hook (requires 5.035-488.0)
□ 8.600-251.0	Cable asm, bat. Jumper x 15' (required w/ no battery units)
□ 4.035-345.0	Quick fill tank system (requires 9.083-003.0)
□ 9.083-003.0	Hose coupling
□ 6.273-205.0	Squeegee blade set, anti stripe oil resistant
□ 6.273-291.0	Squeegee blade set, for textured floors
□ 4.035-408.0	KIK Key

■ Included   □ Optional

## SERVICES

PART NO.	DESCRIPTION
□ 7.000-270.0	Fleet one year premium subscription

# BD 70/75 W BP CLASSIC

This economically-designed scrubber provides you all the cleaning power to take on large jobs—perfect for retail environments, grocery stores, municipalities, and BSC's.

- Adaptable to specific floor type cleaning needs
- Large aluminum brush deck is tough and durable
- Wet and AGM battery options are available



BD 70/75 W BP CLASSIC

TECHNICAL SPECIFICATIONS			
Cleaning path/width		in	28
Brush type	cylindrical/disc/pad		pad
Brush quantity		units	2
Brush diameter		in	14
Suction bar (squeegee) width		in	41
Drive	pad-assist/traction		traction
Solution/recovery capacity		gal	19.8 / 19.8
Theoretical/practical productivity		sq. ft/hr	30,645 / 19,920
Operating noise level		dBA	63
Battery charger	shelf/on board		shelf
Brush contact pressure		lbs	66 - 150
Brush speed		rpm	180
Vac motor rating		watts	500
Vac motor suction		cfm	51
Waterlift		in of water	64
Weight with batteries		lbs	512 wet / 556 AGM
Dimensions (LxWxH)		in	57 x 30 x 42

PART NO.	DESCRIPTION
9.841-466.0	BD 70/75 W Bp Classic, 185 Ah wet batteries, shelf charger
9.841-467.0	BD 70/75 W Bp Classic, 190 Ah AGM batteries, shelf charger

ACCESSORIES	
PART NO.	DESCRIPTION
■ 4.762-590.0	Pad drive board STRONG (standard)
■ 6.369-003.0	Pad red, medium-soft (standard), set of 5
■ 8.663-291.0	Battery 6V/190 Ah AGM (standard with 9.841-467.0) (4 REQUIRED)
■ 8.622-835.0	Battery 6V/185 Ah wet (standard with 9.841-466.0) (4 REQUIRED)
■ 8.643-374.0	Shelf charger for 190Ah AGM batteries
■ 8.644-222.0	Shelf charger for 185Ah Wet batteries
■ 4.777-108.0	Squeegee, 1030mm (standard w/suction blades)
■ 4.037-144.0	Suction blades, 1030mm, blue (standard)
□ 4.905-010.0	Disc brush, red, medium
□ 4.905-013.0	Disc brush, black, hard
□ 4.905-012.0	Disc brush, natural, soft
□ 4.905-011.0	Disc brush, white, very soft
□ 4.037-145.0	Suction blades, 1030 mm (polyurethane)
□ 4.444-015.0	Suction hose accessory
□ 9.753-088.0	Squeegee transport plate
□ 2.644-140.0	Warning beacon add-on kit

■ Included □ Optional

# BD 80/100 W BP CLASSIC

This economically-designed scrubber provides you all the cleaning power to take on large jobs—perfect for retail environments, grocery stores, and BSCs.



- Storage compartment in the back for shelf charger and other accessories
- Perfect recovery in 180 degree turns.
- An automatic brake is integrated into the transaxle and a cost effective, large aluminum brush deck is included.

## BD 80/100 W BP CLASSIC

TECHNICAL SPECIFICATIONS			
Cleaning path/width	in		32
Brush type	cylindrical/disc/pad	pad	
Brush quantity	units		2
Brush diameter	in		16
Suction bar (squeegee) width	in		46
Drive	pad-assist/traction	traction	
Solution/recovery capacity	gal		26.4 / 26.4
Theoretical/practical productivity	sq. ft/hr		35,025 / 22,770
Operating noise level	dBA		63
Battery charger	shelf/on board	shelf	
Brush contact pressure	lbs		88 - 200
Brush speed	rpm		180
Vac motor rating	watts		600
Vac motor suction	cfm		53
Waterlift	in of water		67
Weight with batteries	lbs		705
Dimensions (LxWxH)	in		59 x 33 x 42

PART NO.	DESCRIPTION
9.841-456.0	BD 80/100 W Bp Classic, 295 Ah wet batteries, shelf charger
9.841-457.0	BD 80/100 W Bp Classic, 285 Ah AGM batteries, shelf charger

ACCESSORIES	
PART NO.	DESCRIPTION
■ 4.762-591.0	Pad drive board
■ 6.371-332.0	Pad, red, medium-soft
■ 8.629-184.0	Battery, Discover 6V/285 Ah AGM
■ 8.622-837.0	Battery, Trojan 6V/271 Ah wet
■ 8.643-373.0	Shelf charger for wet batteries
■ 8.643-374.0	Shelf charger for AGM batteries
■ 4.777-102.0	Squeegee, 1100 mm
■ 4.037-138.0	Suction blades, 1230 mm, blue

ACCESSORIES	
PART NO.	DESCRIPTION
<input type="checkbox"/> 4.905-000.0	Disc brush, red, medium
<input type="checkbox"/> 4.905-032.0	Disc brush, black, hard
<input type="checkbox"/> 4.905-031.0	Disc brush, natural, soft
<input type="checkbox"/> 4.905-030.0	Disc brush, white, very soft
<input type="checkbox"/> 4.037-140.0	Suction blades 1230 mm, transparent
<input type="checkbox"/> 9.753-088.0	Squeegee transport plate
<input type="checkbox"/> 2.644-140.0	Warning beacon add-on kit

■ Included  Optional



# B 110 R

The brand-new B 110 R is perfect for all floors. The robust front bumper prevents damage to the machine and other objects, while speed dependent water supply saves on water and detergents. The newly designed squeegee picks up more water and requires less attention and the adjustable seat allows workers to feel more comfortable during long shifts.

### Advanced updates for a top-of-the-line machine

- Front bumper and driving lights
- Side scrub deck for close to the edge cleaning
- Adjustable comfort seat
- Hill driving assistant and automatic electronic brake



### B 110 R

#### TECHNICAL SPECIFICATIONS

Cleaning path/width	in	30
Brush type	cylindrical/disc/pad	Cylindrical and disc
Brush quantity	units	2
Brush diameter	in	4" cylindrical, 15" disc
Suction bar (squeegee) width	in	37
Drive	pad-assist/traction	Traction
Solution/recovery capacity	gal	29/29
Theoretical/practical productivity - 30" deck	sq. ft/hr	48,440/31,485
Operating noise level	dBA	59-74
Battery charger	shelf/on board	Shelf
Brush contact pressure	lbs	165
Brush speed	rpm	180/1200
Drive /vac motor rating	watts	600
Vac motor suction	cfm	53
Waterlift	in of water	68
Weight with batteries	lbs	1190
Dimensions (LxWxH)	in	65 x 30 x 52
Minimum turning radius	ft	2.87
Climbing ability - maximum slope	% grade	10
Max. working speed	mph	3.8

#### EQUIPMENT

Order No.	Description
9.841-441.0	BD 75/110 R Bp Wet, 30" disc scrub deck
9.841-444.0	BD 75/110 R Bp AGM, 30" disc scrub deck
9.841-445.0	BR 75/110 R Bp Wet, 30" cylindrical scrub deck
9.841-449.0	BR 75/110 R Bp AGM, 30" cylindrical scrub deck

See Cleaning Heads & Brushes section for available scrub decks.

# B 110 R ACCESSORIES

## ACCESSORIES

Order No.	Description
■ 4.778-007.0	950 mm parabolic squeegee
■ 2.763-005.0	D 75 scrub deck (depending on model selected)
■ 2.763-047.0	R 75 scrub deck (depending on model selected)
■ 4.039-366.0	Linatex squeegee blade set
■ 4.035-605.0	Red brush for R 75 scrub deck
■ 6.907-731.0	Green brush for R 75 scrub deck
□ 6.907-732.0	Black brush for R 75 scrub deck
□ 6.907-730.0	Orange brush for R 75 scrub deck
□ 6.907-729.0	White brush for R 75 scrub deck
□ 4.039-357.0	Polyurethane replacement squeegee blade
□ 8.644-917.0	Right side scrub deck (factory install only)
□ 2.644-231.0	Spray suction kit
□ 4.039-350.0	Warning beacon kit
□ 4.039-327.0	Lid with tank rinsing
□ 2.644-245.0	Dose system
□ 4.035-406.0	Home base box
□ 4.039-349.0	Mop Home Base Attachment Kit
□ 8.622-835.0	Trojan T105 225 Ah battery
□ 8.632-254.0	Discover EVGT6A-A 255 Ah battery
□ 8.644-222.0	Shelf charger for wet batteries
□ 8.643-374.0	Shelf charger for AGM batteries

■ Included □ Optional

# B 150 R BP

The B 150 R can cover up to 58,125 ft<sup>2</sup>/hr making this one impressively productive scrubber. Although it can cover large areas quickly, we made sure that it has great visibility for safety. Our KIK operating system and the color coded controls make operation simple and intuitive. KIK allows managers to control what functions and settings their employees can use and adjust.

- Clean ramps with grades up to 18%
- Features a unique all-wheel brake system for safety
- Utilize the large color LCD screen to adjust everything to your needs including contact pressure, water volume, brush speed, etc.
- Auto tank-rinsing and auto-fill come standard to allow the operator to do other tasks while rinse and fill are taking place



		B 150 R + R 75	B 150 R + D 75	B 150 R + R 90	B 150 R + D 90
<b>TECHNICAL SPECIFICATIONS</b>					
Cleaning path / width	in	30	30	35	35
Brush type	<b>cylindrical / disc / pad</b>	cylindrical	disc	cylindrical	disc
Brush quantity	<b>units</b>	2	2	2	2
Brush diameter	in	3.5	7.5	3.5	17.7
Suction bar (squeegee) width	in	37	37	42	42
Drive	<b>pad-assist / traction</b>	traction	traction	traction	traction
Solution / recovery capacity	gal	40 / 40	40 / 40	40 / 40	40 / 40
Theoretical / practical productivity	<b>sq. ft / hr</b>	48,438 / 31,485	48,438 / 31,485	58,125 / 37,780	58,125 / 37,780
Operating noise level - std / Eco! mode	<b>dBA</b>	67 / 64	67 / 64	67 / 64	67 / 64
Battery charger	<b>shelf / on-board</b>	shelf	shelf	shelf	shelf
Brush contact pressure	<b>lbs</b>	245	224	275	238
Brush speed	<b>rpm</b>	1,200	140	1,200	140
Drive / vac motor rating	<b>watts</b>	600 / 750	600 / 750	600 / 750	600 / 750
Vac motor suction	<b>cfm</b>	55	55	55	55
Waterlift	<b>in of water</b>	72	72	72	72
Weight without batteries	<b>lbs</b>	959-1,146	959-1,146	959-1,146	959-1,146
Dimensions (LxWxH)	in	65 x 31 x 56	65 x 31 x 56	65 x 31 x 56	65 x 31 x 56
Minimum turning radius	ft	2.9	2.9	2.9	2.9
Climbing ability - maximum slope	<b>% grade</b>	10	10	10	10

# B 150 R BP EQUIPMENT & ACCESSORIES

PART NO.	DESCRIPTION
9.841-286.0	B 150 R Bp, scrub deck sold separately, 36V/360 Ah batteries
9.841-287.0	B 150 R Bp 2SB, scrub deck sold separately, 36V/360 Ah batteries, dual side brushes
9.841-288.0	B 150 R Bp ADV, scrub deck sold separately, 36V/360 Ah batteries
9.841-289.0	B 150 R Bp 2SB ADV, scrub deck sold separately, 36V/360 Ah batteries, dual side brushes
9.841-290.0	B 150 R Bp, R 75 cylindrical scrub deck, 36V/360 Ah batteries
9.841-291.0	B 150 R Bp, R 75 cylindrical scrub deck, 36V/312 Ah AGM batteries
9.841-294.0	B 150 R Bp 2SB, R 75 cylindrical scrub deck, 36V/360 Ah batteries, dual side brushes.
9.841-295.0	B 150 R Bp 2SB, R 75 cylindrical scrub deck, 36V/312 Ah AGM batteries, dual side brushes.
9.841-292.0	B 150 R Bp, R 90 cylindrical scrub deck, 36V/360 Ah batteries.
9.841-293.0	B 150 R Bp, R 90 cylindrical scrub deck, 36V/312 Ah AGM batteries.
9.841-296.0	B 150 R Bp 2SB, R 90 cylindrical scrub deck, 36V/360 Ah batteries, dual side brushes.
9.841-297.0	B 150 R Bp 2SB, R 90 cylindrical scrub deck, 36V/312 Ah AGM batteries, dual side brushes.
9.841-367.0	B 150 R Bp, Scrub deck sold separately, 36V/312 Ah AGM batteries
9.841-368.0	B 150 R Bp 2SB, scrub deck sold separately, 36V/312 Ah AGM batteries, dual side brushes
9.841-365.0	B 150 R Bp ADV, scrub deck sold separately, 36V/312 Ah AGM batteries
9.841-366.0	B 150 R Bp 2SB ADV, scrub deck sold separately, 36V/312 Ah AGM batteries, dual side brushes

## ACCESSORIES

PART NO.	DESCRIPTION
■ 4.777-4120	Squeegee assembly, 37-inch, v-shaped polyurethane oil-resistant blades, standard on machines with R 75 & D 75 scrub decks
■ 4.777-413.0	Squeegee assembly, 42-inch, curved polyurethane oil-resistant blades, standard on machines with R 90 & D 90 scrub decks
■ 8.622-842.0	6V/360 Ah wet batteries
■ 8.629-184.0	Battery, 6V/312 Ah AGM battery
■ 8.628-408.0	Battery charger, 36V, 36A, 115V. For use with 8.622-842.0
■ 8.600-015.0	AGM battery charger, 36V, 21A, 115V
□ 2.642-058.0	Spray Suction Kit - for Cleaning Areas Not Easily Accessed by Machine (field installation required)
□ 6.435-733.0	Non-marking rear wheel, for use on sensitive floors that mark easily (field installation required)
□ 4.444-015.0	Suction hose accessories, for taking in water from corners (e.g. deep freezers)
□ 4.035-516.0	360° Warning Beacon (field installation required)
□ 4.777-402.0	37-inch straight squeegee assembly, for machines with R 75 scrub deck
□ 4.777-403.0	42-inch straight squeegee assembly, for machines with R 90 scrub deck
□ 6.273-215.0	Blue squeegee blade (2 required)
□ 6.273-209.0	Brown, oil-resistant squeegee blade
□ 6.273-206.0	Brown, streak-free, oil-resistant squeegee blade
□ 2.641-811.0	Cleaning agent dosing system DS 3 - Can be directly connected to the main water supply; the fresh water tank is filled with the mixture of water and cleaning agent. Also in connection with the ABS filling system.
□ 6.435-810.0	Front tires, traction - with V profile and tire compound with especially good traction properties. Oil-proof.
□ 6.951-073.0	Replacement side broom, for use with R-type scrub decks (1-pack)

■ Included □ Optional

## SERVICES

PART NO.	DESCRIPTION
□ 7.000-270.0	Fleet one year premium subscription

# CLEANING HEADS FOR B SERIES SCRUBBERS

We offer three different scrub decks to suit your unique needs. The three types R (cylindrical), D (disc) or S (vibration) each have their specific advantages. Disc decks are ideal for everyday scrubbing. Cylindrical heads are ideal for stubborn dirt or uneven surfaces. The S heads are very efficient at stripping of floors. No matter your need, Kärcher has you covered.

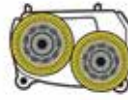

D-Series  
Disc Heads

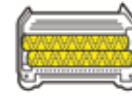

R-Series  
Cylindrical Heads

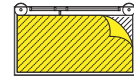

S-Series  
Vibration Heads

## D 43 | 17-INCH DISC SCRUB DECK

PART NO.	DESCRIPTION	
2.763-023.0	D 43 head, 17-inch scrub deck for all battery-powered B 40 units	■
4.762-533.0	Pad driver	■
6.905-526.0	Disc microfiber pad, for daily cleaning of delicate surfaces including LVT and stone tile	■
4.905-023.0	Disc brush, natural fibers	■
6.369-470.0	Disc pad, red (general purpose/standard)	■
4.905-022.0	Red disc brush, 17-inch	■
4.905-024.0	Disc brush, white 17-inch	■
4.905-025.0	Disc brush, black 17-inch	■
6.369-472.0	Disc pad green (aggressive)	■
6.369-473.0	Disc pad black (very aggressive)	■
6.369-469.0	Disc pad white (soft)	■
6.371-081.0	Disc pad beige (light aggregate)	■
6.371-149.0	Disc pad, natural	■

## D 51 | 20-INCH DISC SCRUB DECK

PART NO.	DESCRIPTION	
2.763-026.0	D 51 head, 20" / 510mm Scrub Deck for all Battery-Powered B 40 units	■
8.642-710.0	One time conversion kit, D 51 orbital head (for serial # 10358 and higher) *	■
8.638-801.0	Assembly, Deck, D 51 orbital (replacement deck assembly)	■
4.905-026.0	Disc brush, medium grit, red, for general cleaning (standard on brush machines)	■
4.905-028.0	Disc brush, very soft, for cleaning sensitive floors and polishing, white	■
4.905-029.0	Disc brush, hard, for stubborn dirt and deep cleaning. Only for hard-wearing surfaces, black	■
4.905-027.0	Disc brush, soft, made of natural fibers, for cleaning and polishing	■
4.762-534.0	Pad driver, 19 inch, features a quick-change coupling and centerlock (standard on pad driver machines)	■
6.371-271.0	Disc microfiber pad, for daily cleaning of delicate surfaces including LVT and stone tile	■
6.369-079.0	Red disc pad, 20-inch, medium soft red for cleaning all types of floors, 5-pack	■
6.369-078.0	Green disc pad, 20-inch, aggressive for cleaning heavily soiled floors and for deep cleaning, 5-pack	■
6.369-077.0	Black pad, 20-inch, hard, for cleaning heavily soiled floors and for deep cleaning, 5 pack	■
6.369-468.0	Beige disc pad, 20-inch, light grit, for polishing and refreshing of hard and elastic smooth floor coverings, 5 pack	■
6.371-146.0	Beige disc pad, 20 inch, soft, natural hair, for polishing	■

## D 55 | 22-INCH DISC SCRUB DECK

PART NO.	DESCRIPTION	
2.763-001.0	D 55 brush head, disc head, 22-inch	■
4.905-015.0	Disc brush, white - soft	■
4.905-016.0	Disc brush, natural bristles	■
4.905-014.0	Disc brush, red, standard with D 55 head	■
4.905-017.0	Disc brush, black - very aggressive	■
4.762-445.0	Pad driver	■
6.371-153.0	Disc pad, red (soft)	■
6.371-154.0	Disc pad, green (medium)	■
6.371-155.0	Disc pad, black (hard)	■

# CLEANING HEADS FOR B SERIES SCRUBBERS

D 65   26-INCH DISC SCRUB DECK		
PART NO.	DESCRIPTION	
2.763-003.0	D 65 brush head, disc head, 26-inch	■ ■
4.905-011.0	Disc brush, white - soft	■ ■
4.905-012.0	Disc brush, natural bristles	■ ■
4.905-010.0	Disc brush, red, standard with D 65 head	■ ■
4.905-013.0	Disc brush, black - very aggressive	■ ■
4.762-446.0	Pad driver	■ ■
6.369-003.0	Red disc pads, set of 5	■ ■
6.369-002.0	Green disc pads, medium soft, green, set of 5	■ ■
6.369-001.0	Black disc pads, hard, set of 5	■ ■
6.369-959.0	Disc microfiber pad, for daily cleaning of delicate surfaces including LVT and stone tile	■ ■
D 75   30-INCH DISC SCRUB DECK		
PART NO.	DESCRIPTION	
2.763-005.0	D 75 brush head, disc head, 30-inch	■ ■
4.905-019.0	Disc brush, white - soft	■ ■
4.905-020.0	Disc brush, natural bristles	■ ■
4.905-018.0	Disc brush, red, standard with D 75 head	■ ■
4.905-021.0	Disc brush, black - very aggressive	■ ■
4.762-447.0	Pad driver	■ ■
6.369-791.0	Disc pad, red (soft)	■ ■
6.369-790.0	Disc pad, green (medium)	■ ■
6.369-789.0	Disc pad, black (hard)	■ ■
6.371-078.0	Disc microfiber pad, for daily cleaning of delicate surfaces including LVT and stone tile	■ ■
D 90   36-INCH DISC SCRUB DECK		
PART NO.	DESCRIPTION	
2.763-008.0	D 90 brush head, disc, 36-inch	■
4.905-003.0	Disc brush, red, standard with D 90 head	■
4.905-004.0	Disc brush, natural bristles	■
4.905-005.0	Disc brush, white - soft	■
4.905-006.0	Disc brush, black - very aggressive	■
4.762-493.0	Pad driver	■
6.369-022.0	Disc pad, black - hard	■
6.369-023.0	Disc pad, green - medium	■
6.369-024.0	Disc pad, red - soft	■
R 45   18-INCH CYLINDRICAL SCRUB DECK		
PART NO.	DESCRIPTION	
2.763-020.0	R 45 head, 18-inch scrub deck for non-traction drive machines (for C Units)	■
2.763-019.0	R 45 head, 18-inch scrub deck for traction drive machines (for W Units)	■
4.762-392.0	Cylindrical red brush, medium stiff bristles for all-around cleaning on smooth and textured floors	■
4.762-405.0	Cylindrical white brush, soft bristles for gentle cleaning on all-surface floors	■
4.762-406.0	Cylindrical orange brush, high-low bristles for cleaning all grouted surface floors	■
4.762-407.0	Cylindrical green brush, stiff bristles for aggressive cleaning on irregular surface floors	■
4.762-408.0	Cylindrical black brush, extremely stiff bristles for stubborn dirt on rugged floors	■
4.762-413.0	Cylindrical pad shaft (required for all brushes below)	■
4.114-009.0	Cylindrical microfiber pad, for daily cleaning of delicate surfaces including LVT and stone tile	■
6.367-105.0	Cylindrical pad, yellow (soft)	■
6.367-107.0	Cylindrical pads, red, general purpose	■
6.367-108.0	Cylindrical pad, white, (very soft) for high-gloss floors	■
6.367-106.0	Cylindrical pad, green (hard & aggressive)	■



# CLEANING HEADS & BRUSHES

## R 55 | 22-INCH CYLINDRICAL SCRUB DECK

PART NO.	DESCRIPTION		
2.763-013.0	R 55 head, 22-inch scrub deck for non-traction drive machines (for B 40 C units)	■	
2.763-011.0	R 55 head, 22-inch scrub deck for traction drive machines (for B 40 W, B 60 & B 90 units)	■	■
4.035-184.0	Roller brush complete for replacement BR	■	
4.762-409.0	Cylindrical white brush, 22-inch, soft	■	
4.762-410.0	Cylindrical orange brush, 22-inch, high/low bristles for uneven floors	■	
4.762-411.0	Cylindrical green brush, 22-inch, hard bristles	■	
4.762-412.0	Cylindrical brush black 22-inch	■	
4.762-415.0	Cylindrical pad shaft, 22-inch, 2 required	■	
8.635-692.0	Cylindrical, stripping 22-inch	■	
4.114-010.0	Cylindrical microfiber pad, 22-inch, for daily cleaning of delicate surfaces including LVT and stone tile	■	
6.369-732.0	Yellow pad, 22-inch	■	
6.369-734.0	Red pad, 22-inch, medium grit for all-around cleaning on smooth and textured floors	■	
6.369-735.0	White pad, includes sleeve, 22-inch	■	
6.369-733.0	Green pad, 22-inch	■	
2.763-002.0	R 55 head, cylindrical, 22-inch		■
6.906-977.0	Cylindrical brush, white, soft		■
4.035-193.0	Roller brush red for replacement BR 55		■
6.906-978.0	Cylindrical brush, orange, hi-lo grout brush		■
6.906-979.0	Cylindrical brush, green, hard		■
6.906-980.0	Cylindrical brush, black, very aggressive		■
8.635-692.0	Cylindrical, stripping 22-inch		■
4.762-432.0	Cylindrical brush, red (2 required)		■
6.369-389.0	White cylindrical pad, extra soft, set of 20		■
6.369-454.0	Yellow cylindrical pad, soft, set of 20		■
6.369-455.0	Green cylindrical pad, hard, set of 20		■
6.369-456.0	Red cylindrical pad, medium, set of 20		■

## R 65 | 26-INCH CYLINDRICAL SCRUB DECK

PART NO.	DESCRIPTION		
2.763-004.0	R 65 brush head, cylindrical, 26-inch	■	■
6.906-981.0	Cylindrical white brush, soft	■	■
4.035-187.0	Roller brush red for replacement BR65	■	■
6.906-982.0	Cylindrical orange brush, high-low for grout	■	■
6.906-983.0	Cylindrical green brush, hard	■	■
6.906-984.0	Cylindrical black brush, very aggressive	■	■
4.762-433.0	Cylindrical Pad Shaft	■	■
6.369-389.0	White cylindrical pad, extra soft, set of 20	■	■
6.369-454.0	Yellow cylindrical pad, soft, set of 20	■	■
6.369-455.0	Green cylindrical pad, hard, set of 20	■	■
6.369-456.0	Red cylindrical pad, medium, set of 20	■	■

## R 75 | 30-INCH CYLINDRICAL SCRUB DECK

PART NO.	DESCRIPTION		
2.763-006.0	R 75 brush head, cylindrical, 30-inch	■	■
6.906-985.0	Cylindrical brush, white, soft	■	■
4.035-190.0	Roller brush red for replacement BR 75	■	■
6.906-986.0	Cylindrical brush, orange, hi-lo grout brush	■	■
6.906-987.0	Cylindrical brush, green, hard	■	■
6.906-988.0	Cylindrical brush, black, very aggressive	■	■
4.762-434.0	Cylindrical pad shaft	■	■
6.369-389.0	White cylindrical pad, extra soft, set of 20	■	■
6.369-454.0	Yellow cylindrical pad, soft, set of 20	■	■
6.369-455.0	Green cylindrical pad, hard, set of 20	■	■

# CLEANING HEADS & BRUSHES

## R 90 | 36-INCH CYLINDRICAL SCRUB DECK

PART NO.	DESCRIPTION	
2.763-007.0	R 90 brush head, cylindrical, 36-inch	■
6.906-989.0	Cylindrical white brush, soft, 36-inch	■
6.907-377.0	Cylindrical red brush, 36-inch	■
6.906-990.0	Cylindrical orange brush, high-low for grout, 36-inch	■
6.906-991.0	Cylindrical green brush, hard, 36-inch	■
6.906-992.0	Cylindrical black brush, very aggressive, 36-inch	■
4.762-189.0	Cylindrical pad shaft	■
6.369-389.0	White cylindrical pad, extra soft, set of 20	■
6.369-454.0	Yellow cylindrical pad, soft, set of 20	■
6.369-455.0	Green cylindrical pad, hard, set of 20	■

## S 65 | 26-INCH VIBRATION SCRUB DECK

PART NO.	DESCRIPTION		
2.763-030.0	S 65 brush head, oscillating scrub deck, 26-inch	■	■
4.036-063.0	S 65 orbital head connection kit, required for connecting S 65 orbital, B 60 and B 80 units (required)	■	■
4.036-061.0	S 65 orbital head connection kit, required for connecting S 65 orbital, B 90 units (required)	■	■
8.635-789.0	Pad, S 65 surface prep, package of 5	■	■
8.635-788.0	Pad, S 65, red, package of 5	■	■
8.635-836.0	Pad, S 65, white, package of 5	■	■

# BDS 51/175 C

The BDS 51/175 C floor machine is a high quality, durable unit that offers power and versatility for scrubbing and stripping. It features an adjustable handle to accommodate various user heights and five inch non-marking wheels to allow easy transportation. This machine is available in single-speed or dual-speed.

- Robust motor for everyday reliability
- Separate start and run capacitors for durability
- Cord strain relief to keep cord from breaking or tearing
- Strong and solid handle housing for trouble free operation



BDS 51/175 C

## TECHNICAL SPECIFICATIONS

Pad size	in	20
Pad speed	rpm	175
Theoretical / practical productivity	sq. ft / hr	2,222
Operating noise level	dba	63
Voltage	V	115
Motor	hp	1.5
Wheel diameter	in	5 x 1.25
Power cord length	ft	50
Weight	lbs	118
Dimensions (LxWxH)	in	24.5 x 21 x 47

PART NO.	DESCRIPTION
1.009-095.0	BDS 51/175 C, twenty-inch

## ACCESSORIES

PART NO.	DESCRIPTION
■ 8.628-430.0	Pad driver, 20-inch with clutch plate
<input type="checkbox"/> 8.600-062.0	Solution tank 4 gallon
<input type="checkbox"/> 8.600-507.0	Center lock
<input type="checkbox"/> 8.628-369.0	20-inch aggressive grit brush with clutch plate
<input type="checkbox"/> 8.628-378.0	20-inch mild grit brush with clutch plate
<input type="checkbox"/> 8.628-379.0	20-inch nylon polish brush with clutch plate
<input type="checkbox"/> 8.628-377.0	20-inch nylon scrub brush with clutch plate
<input type="checkbox"/> 8.628-370.0	20-inch polypropylene brush with clutch plate
<input type="checkbox"/> 8.625-259.0	20-inch sanding disc

■ Included     Optional

# SGV 6/5

The easy-to-use SGV 6/5 steam vacuum cleaner offers hygienic cleanliness. A single machine that is a steam cleaner and wet vacuum cleaner in one. With EASY Operation switch, secure accessory integration and hand tool for controlling the steam/vacuum function.

- One easy-to-use switch controls all operation
- Self-explanatory symbols means less training required
- Our unique design allows you to refill the water while in use
- The included hand tool features an adjustment knob that allows you to adjust the water/steam regulation and turn the vacuum on and off



## SGV 6/5

### TECHNICAL SPECIFICATIONS

<b>Voltage</b>	<b>V</b>	110-120
<b>Steam temp / pressure</b>	<b>oF / psi</b>	327 / 87
<b>Tank capacity</b>	<b>gal</b>	1.3
<b>Cable length</b>	<b>in</b>	24.5
<b>Weight without accessories</b>	<b>lbs</b>	86
<b>Dimensions (LxWxH)</b>	<b>in</b>	25 x 19 x 38

PART NO.	DESCRIPTION
1.092-003.0	SGV 6/5, commercial steam cleaner and wet vacuum

### ACCESSORIES

PART NO.	DESCRIPTION
■ 2.863-011.0	Round brush set, 3 Brushes
■ 2.889-005.0	Floor Nozzle, 12 inches
■ 2.889-006.0	Brush strips for floor nozzle 2.889-005.0
■ 2.889-007.0	Rubber Strip, 12 inches for floor nozzle 2.889-005.0
■ 2.889-008.0	Hand Nozzle
■ 2.889-009.0	Brush Strip, 6 inches for hand nozzle 2.889-008.0
■ 2.889-010.0	Rubber Strip, 6 inches for hand nozzle 2.889-008.0
■ 2.889-011.0	Adapter
■ 2.889-028.0	Crevice Nozzle
■ 2.889-052.0	Adapter for attaching round brushes
■ 4.440-009.0	Steam suction hose
■ 2.889-004.0	Extension tube set (2 pcs)
□ 2.889-058.0	Extension tube set (1 pc)
□ 2.889-053.0	Triangular floor nozzle
□ 2.863-007.0	Round brush stainless steel (very hard bristles) set, 3 Nozzles
□ 2.863-008.0	Round Brass Brush (hard bristles) Set, 3 Nozzles
□ 2.863-009.0	Pekalon round brush (medium-hard bristles) set

- Included   □ Optional

# SG 4/4

Time is money—particularly in commercial cleaning. The SG 4/4 steamer has an ingenious two-tank filling system allowing for continuous use. Steam cleaning can impressively remove up to 99.999% of bacteria without chemical. It is also ideal for cleaning kitchens and grout.

- Our unique two-tank system allows for continuous use
- Very little time is needed to heat up the unit
- Control the level of steam
- Switch to pressurized hot water to remove stubborn dirt
- Only water is used by the SG 4/4 to save you money and to improve the health of users and guests



## SG 4/4

### TECHNICAL SPECIFICATIONS

<b>Voltage</b>	<b>V</b>	110
<b>Steam temp / pressure</b>	<b>oF / psi</b>	248 / 58
<b>Tank capacity</b>	<b>gal</b>	1.06
<b>Cable length</b>	<b>in</b>	24.5
<b>Weight without accessories</b>	<b>lbs</b>	17.6
<b>Dimensions (LxWxH)</b>	<b>in</b>	19 x 12.6 x 10.8

PART NO.	DESCRIPTION
1.092-805.0	SG 4/4, commercial steam cleaner
9.841-414.0	SG 4/4, commercial steam cleaner with transport cart

### ACCESSORIES

PART NO.	DESCRIPTION
■ 4.322-046.0	Steam Hose
■ 4.127-024.0	Extension Tube
■ 2.884-280.0	Hand Tool
■ 6.906-185.0	Floor Nozzle
■ 2.863-263.0	Power Nozzle Set
■ 2.884-281.0	Point Jet Nozzle
■ 4.013-030.0	Funnel
■ 2.863-264.0	Round Brush Set
□ 2.863-025.0	Window Nozzle Special Accessories
□ 6.273-140.0	Wiper Blade (window)
□ 2.863-062.0	Wallpaper Stripper
□ 2.863-171.0	Steam+Clean Microfiber Cloth Set for Bathrooms (Includes 4 different clothes)
□ 2.863-172.0	Steam+Clean Microfiber Cloth Set for Kitchens (Includes 4 different clothes)
□ 2.863-173.0	Steam+Clean Microfiber Velour Floor Cloth Set (Includes 2 cloths)
□ 2.863-174.0	Steam+Clean Microfiber Velour Cloth Covers for the Hand Tool (Includes 2 cloths)
□ 6.962-097.0	Filling Funnel
□ 2.885-465.0	Floor Tool Replacement
□ 6.962-239.0	Two Wheel Transport Cart

■ Included    □ Optional

# HD 2.0/1000 DUAL MISTER & DUAL MISTER CART

## AN ALL-IN-ONE MISTER AND PRESSURE WASHER

### HD 2.0/1000 Dual Mister and Dual Mister Cart

Kärcher's cold water, corrosion-resistant aluminum Dual Mister easily converts from a pressure washer to a mister for dispensing sanitizer or disinfectants, such as Vital Oxide®.<sup>1</sup> This reliable electric powered pressure washer comes standard with a humidifying nozzle and an Easy!Valve that allows the operator to easily switch from pressure washing to misting mode. The Dual Mister Cart is easy-to-manuever with flat-free tires, two mounted hose reels, and provides a bypass loop for additional pump protection. In short, this unit is designed to combat viruses and bacteria in directional sprayer mode, or it can be used as a high pressure washer to clean surfaces. Your choice.



TECHNICAL SPECIFICATIONS		HIGH PRESSURE MODE	SPRAYER MODE
Pressure	psi	1000	107-480
Solution spray rate	gpm	2.0	0.023-0.06
Drive		Direct	Direct
Voltage	V	120 / 1ph	120 / 1ph
Pump	RPM	1725	1725
Amps		13.6	6.5 - 8.0
HP		1.5	1.5
Shipping Weight	lbs	161 / Cart - 285	161 / Cart - 285
Dimensions (L x W x H)	in	41 x 22 x 25 / Cart - 41 x 36 x 50	41 x 22 x 25 / Cart - 41 x 36 x 50

### EQUIPMENT

PART NO.	DESCRIPTION
1.106-160.0	HD 2.0/1000 Dual Mister
1.106-161.0	HD 2.0/1000 Dual Mister Cart

### ACCESSORIES

PART NO.	DESCRIPTION
■ 8.750-247.0*	Gun, M407 (2 for dual gun system)
■ 8.925-393.0*	Hose, 1/4" X 75', R1, 4000 PSI, SW X SW
■ 8.783-040.0	Lance, 44", zinc-plated, handle and coupler
■ 8.712-338.0	Nozzle, yellow, 035
■ 8.712-339.0	Nozzle, green, 035
■ 8.712-340.0	Nozzle, white, 035
■ 8.929-512.0*	Misting Nozzle Assembly with 1/4" Quick Connect
■ 8.709-175.0	Filter High Pressure 1/4"
□ 8.902-421.0*	Two-Gun Tee Coupler

■ Included □ Optional

<sup>1</sup> Corrosive sanitizers or disinfectants will void the warranty.

\*Must order for dual gun misting system / two gun coupler for 1.106-160.0.

### ACCESSORIES

PART NO.	DESCRIPTION
□ 8.710-620.0	Legacy Superlite stainless steel wand, 72"
□ 9.807-750.0	37.5" long handle
□ 9.807-753.0	Lance holder
□ 9.807-752.0	Hose storage hook
□ 9.807-751.0	Handle with hose reel (mild steel anthracite handle)
□ 9.802-166.0*	3/8" Socket, Female, Brass
□ 9.802-169.0*	3/8" Socket, Male, Brass
□ 8.707-140.0*	1/4" Nipple, Male, Stainless Steel
□ 8.707-144.0*	3/8" Nipple, Female, Stainless Steel



# PS 4/7 BP MISTER

## VITAL OXIDE® HOSPITAL DISINFECTANT

### PS 4/7 Bp Mister

Achieve a higher level of efficacy with the Kärcher PS 4/7 Bp Mister. This hospital-grade misting system is specifically designed for use with Vital Oxide® disinfectant. Reduce the risks of Health Care Acquired Infections by killing virus, bacteria and mold faster, safer and quieter.

### PS 4/7 Electrostatic Sprayer

NEW – our Electrostatic PS 4/7 sprayer adds the static charge to the particles to allow them to “wrap around” objects and provide even better coverage.

### Vital Oxide

- No rinse sanitizer for food contact surfaces (D2).
- Kills harmful bacteria, mold and mildew, deodorizes and eliminates allergens.
- Registered as a carpet disinfectant and recognized by CRI to be safe on carpets. EPA Reg. No. 82972-1 EPA Est. No. 85804-NC-1 EPA Est. No. 29909-CA-1 (See batch code for actual (establishment number)
- Represented in Canada by Halifax International Trading Inc. S1394 Pineway Court, Oakville Ontario L6M 2H3 (DIN 24422654)



	PS 4/7 BP OBC MISTER		PS 4/7 ELECTROSTATIC SPRAYER
<b>TECHNICAL SPECIFICATIONS</b>			
Pressure	psi	100	100
Solution spray rate	gpm	0.05	0.05
Chemical Tank	gal	1	1
Continuous spray on one battery charge	hrs	8	8
Voltage	v	12	12
Wheels	in	3	3
Compact height for storage/transport	in	20	20
Sound level	dBA	45	45
Continuous spray time (electrostatic)	hrs	N/A	40
Lithium battery	v	N/A	3.6, AA size
Weight (including battery)	lbs	40	40
Dimensions (L x W x H)	in	20 x 15 x 38	20 x 15 x 38

### EQUIPMENT

PART NO.	DESCRIPTION
1.007-084.0	PS 4/7 Bp OBC, mister
1.007-090.0	PS 4/7 Electrostatic sprayer with lithium battery

### ACCESSORIES

PART NO.	DESCRIPTION
8.639-048.0	Charger
8.637-980.0	12V AGM battery
8.704-694.0	Chemical pail pump
8.644-738.0	Electrostatic sprayer kit (to be retrofitted on previously purchased PS 4/7 machines)

### DETERGENTS

PART NO.	DESCRIPTION
<input type="checkbox"/> 8.698-112.0	Vitaloxide® 55 Gal (US Only)
<input type="checkbox"/> 8.756-449.0	Vitaloxide® 55 Gal (Can Only)
<input type="checkbox"/> 8.642-823.0	Vitaloxide® 15 Gal (US Only)
<input type="checkbox"/> 8.644-292.0	Vitaloxide® 5 Gal (US Only)
<input type="checkbox"/> 8.758-937.0	Vitaloxide® 5 Gal (Can Only)
<input type="checkbox"/> 8.639-558.0	Vitaloxide® Qty 4, 1 Gal (US Only)
<input type="checkbox"/> 8.639-560.0	Vitaloxide® Qty 6, 1 Qt (US Only)
<input type="checkbox"/> 8.639-559.0	Vitaloxide® Qty 4, 1 Gal (Can Only)

■ Included  Optional

# AB 84

Enjoy the convenience that the AB 84 CUL offers in this easily transportable three speed air blower. Time is king in the cleaning industry. If you have wet hard floors or carpet, rely on the AB 84 CUL to dry your facility faster so you can resume to business-as-usual sooner. This unit features transport wheels and an upright handle for easy transport from job to job. The powerful 3,000 cfm air movement promotes rapid drying in no time.

- Upright handle and transport wheels for safety and convenience
- Three speeds of air movement for every type of job
- Maximum air movement of 3,000 cfm for rapid drying of carpeted and hard floors
- Sturdy four point motor mount to withstand heavy use and rough handling
- Built-in carpet clip for flood restoration jobs



## AB 84

### TECHNICAL SPECIFICATIONS

<b>Air flow rate - level 1, 2, 3</b>	<b>cfm</b>	3000 / 2500 / 2000
<b>Fan speed - level 1, 2, 3</b>	<b>rpm</b>	1600 / 1350 / 1050
<b>Power cord length</b>	<b>ft</b>	20
<b>Motor rating</b>	<b>hp</b>	0.5
<b>Voltage</b>	<b>V</b>	115
<b>Weight</b>	<b>lbs</b>	33
<b>Dimensions (LxWxH)</b>	<b>in</b>	15.9 x 18.7 x 18.7

PART NO.	DESCRIPTION
1.004-039.0	AB 84, three-speed commercial air blower with upright handle

# SG BP GUM REMOVER

The Kärcher SG1 C Bp is a portable gum remover. Powered by a single lithium ion battery, this gum remover is quiet and offers up to 4 hours of uninterrupted operation. It removes gum in 4-6 seconds and is safe to use on stone, concrete and even carpet. Great for maintaining shopping malls, schools, train stations, airports, hotels, hospitals, restaurants and supermarkets.

- Low pressure fuel canisters are designed to ensure delivery of proper fuel volume and safe operation*
- No cords ensures safety and convenience*
- No harsh residue—safe on all surfaces*



**SG1 C BP**

**TECHNICAL SPECIFICATIONS**

<b>Run time</b>	<b>hrs</b>	4
<b>Weight</b>	<b>lbs</b>	11
<b>Dimensions (LxWxH)</b>	<b>in</b>	4.5 x 13 x 20.5

<b>PART NO.</b>	<b>DESCRIPTION</b>
1.013-104.0	SG1 C Bp, backpack gum remover

**ACCESSORIES**

<b>PART NO.</b>	<b>DESCRIPTION</b>
<input type="checkbox"/> 8.639-871.0	Service pack: 2 LPG cartridges, 4 bottles of solution and 2 black stainless steel brushes, 1 green brush. Expect 8-9 hours run time.
<input type="checkbox"/> 8.642-880.0	Brush hard black 2 pack replacement stainless steel brushes
<input type="checkbox"/> 8.640-136.0	Polypropylene brushes: 2 pack polypropylene brushes (green), for carpet and material
<input type="checkbox"/> 8.638-579.0	12-Pack of gas bottles
<input type="checkbox"/> 8.638-580.0	24 liters of gum remover solution
<input type="checkbox"/> 8.639-828.0	Charger
<input type="checkbox"/> 8.638-521.0	Battery
<input type="checkbox"/> 8.639-846.0	Lance & hose

■ Included    □ Optional

## HOTSY GUNS

Designed exclusively for Hotsy to meet the demands of the high pressure cleaning professional.



- PSI: 5000
- GPM: 10.5
- Temperature: 320°F
- 3/8" FPT inlet x 1/4" FPT outlet
- Weight: 20 oz.

PART NO.	DESCRIPTION
8.751-235.0 	Hotsy Gun
8.751-119.0	Hotsy Gun Repair Kit



- PSI: 3750
- GPM: 12
- Temperature: 300°F
- 3/8" FPT inlet x 1/4" FPT outlet
- Weight: 24 oz.

PART NO.	DESCRIPTION
8.711-345.0 	Hotsy Gun
8.717-658.0	Hotsy Gun Repair Kit

## HOTSY LANCE GRIP



- Easily fastened to any 1/4" wand
- Zytel material for long life
- 12" in length

PART NO.	DESCRIPTION
8.717-661.0	12" Insulated Grip

## HOTSY SIDE HANDLE

Side handle easily adjusts to provide a safe, ergonomic addition to any straight lance.



- Easily attaches to metal lances
- Fits 1/4" lances

PART NO.	DESCRIPTION
8.706-670.0	Wand Side Handle

## HOTSY DUAL LANCE

The Hotsy dual lance simply out classes the competition. 35" and 48" length to meet UL Standards. Designed specifically for Hotsy to our specifications.



8.711-313.0

- PSI: 3000
- Temperature: 220°F
- Use with downstream injection
- Detergent control side handle

PART NO.	DESCRIPTION
8.711-314.0	35" Cold Water
8.711-315.0	35" Hot Water with Grip
8.711-313.0	48" Hot Water with Grip
8.717-662.0	Repair Kit
8.711-316.0	Brass Body
8.717-268.0	Handle, Valve

## HOTSY HOT WATER LANCE

Hotsy quality through and through. Superior heat protection with zytel insulated grips.



- PSI: 4000
- Temperature: 220°F
- 1/4" plated steel pipe
- 1/4" threads
- Zytel insulated grips

PART NO.	DESCRIPTION
8.711-274.0	15" Lance with Grip
8.752-893.0	28" Lance with Grip
8.904-324.0	36" Lance with Nozzle Protector
8.725-389.0	36" Lance with Grip & Side Handle
8.725-388.0	48" Lance with Grip & Side Handle
8.752-896.0	60" Lance with Grip
8.752-897.0	79" Lance with Grip

## HOTSY COLD WATER LANCE



- 1/4" plated steel pipe
- 1/4" threads

PART NO.	DESCRIPTION	PSI
9.802-214.0	36" Lance with Side	3000
8.711-272.0	48" No Side Handle	4000

# HOTSY HIGH-PRESSURE HOSES

For use with hot or cold-water pressure washers

The Hotsy R1 and R2 high-pressure hoses are built to exceed the EN1829-2 Standard and will provide superior abrasion resistance that will increase the life of the hose. The R1 and R2 hose is rated up to 250°F and is available in 4000, 5000 and 6000 PSI.

Both single- and double-wire braid hoses come with durable bend restrictors on both ends, with a 24-inch bend restrictor on the gun end for added operator protection against high-pressure bursts.

The R1 and R2 hose has a “bite-the-wire” coupling that grips the hose better than any other design.



- *Temperature Rating: R1 and R2 hoses are rated for continuous temperatures up to 250°F.*
- *Easily Identified: Permanently embossed identification makes for easy tracing and owner protection.*
- *Certified Burst Protection: R1 and R2 hose meets the stringent UL-1776 safety standards with two hose guards—including a 24-inch sleeve on the gun end—for added operator protection against bursts.*
- *Unique Coupling: A “bite-the-wire” coupling actually reaches the wire braid for never-slip retention, far superior to the “compression” fittings used on conventional hoses.*

## HOTSY R1 1-WIRE 4000 PSI HOSE



- *PSI: 4000*
- *Hotsy branded black bend restrictor*
- *Smooth impression oil resistant tube and cover with black hose guard, both ends*
- *Rated to 250°F*

PART NO.	SIZE	ID	TEMP	FITTINGS	PSI
<b>3/8" MPT Swivel x 3/8 MPT Swivel</b>					
8.925-151.0	25'	3/8	250°F	SWxSW	4000
8.925-157.0	50'	3/8	250°F	SWxSW	4000
8.925-162.0	75'	3/8	250°F	SWxSW	4000
8.925-166.0	100'	3/8	250°F	SWxSW	4000
8.925-171.0	150'	3/8	250°F	SWxSW	4000
8.925-353.0	200'	3/8	250°F	SWxSW	4000
8.925-379.0	(75) 50'	3/8	250°F	SWxSW	4000
8.925-443.0	(40) 100'	3/8	250°F	SWxSW	4000
<b>3/8" MPT Swivel x 3/8 MPT Swivel x Solid</b>					
8.925-174.0	50'	3/8	250°F	SWxSO	4000
8.925-373.0	100'	3/8	250°F	SWxSO	4000
8.925-352.0	200'	3/8	250°F	SWxSO	4000

## HOTSY R2 2-WIRE 5000 PSI HOSE

PART NO.	SIZE	ID	TEMP	FITTINGS	PSI
<b>1/2" MPT Swivel x 3/8" MPT Solid</b>					
8.925-242.0	50'	1/2	250°F	SWxSO	5000
8.925-248.0	75'	1/2	250°F	SWxSO	5000
8.925-250.0	100'	1/2	250°F	SWxSO	5000

## HOTSY R2 2-WIRE 6000 PSI HOSE



- *PSI: 6000*
- *Hotsy branded red bend restrictor*
- *Smooth impression oil resistant tube and cover with black hose guard, both ends*
- *Rated to 250°F*

PART NO.	SIZE	ID	TEMP	FITTINGS	PSI
<b>3/8" MPT Swivel x 3/8 MPT Swivel</b>					
8.925-181.0	25'	3/8	250°F	SWxSW	6000
8.925-185.0	50'	3/8	250°F	SWxSW	6000
8.925-226.0	75'	3/8	250°F	SWxSW	6000
8.925-230.0	100'	3/8	250°F	SWxSW	6000
8.925-233.0	150'	3/8	250°F	SWxSW	6000
8.925-372.0	200'	3/8	250°F	SWxSW	6000
8.925-444.0	(40)	3/8	250°F	SWxSW	6000
<b>3/8" MPT Swivel x 3/8 MPT Solid</b>					
8.925-374.0	50'	3/8	250°F	SWxSO	6000
8.925-375.0	100'	3/8	250°F	SWxSO	6000
8.925-371.0	200'	3/8	250°F	SWxSO	6000



## HOTSY TUFF-FLEX 1-WIRE 3000 PSI BLUE NON-MAR HOSE



- Hotsy branded black bend restrictor
- Smooth, maximum oil resistant tube blue non-marking cover.
- 20% greater flexibility
- 7 times greater abrasion resistance
- 3/8" MPT Swivel x 3/8" MPT Swivel

PART NO.	SIZE	ID	TEMP	PSI	COLOR
8.739-121.0	<b>S</b> 50'	3/8	250°F	3000	Blue
8.739-123.0	<b>S</b> 100'	3/8	250°F	3000	Blue

## HOTSY TUFF-FLEX 2-WIRE 4500 PSI BLUE NON-MAR HOSE



- Hotsy branded red bend restrictor
- Smooth, maximum oil resistant tube blue non-marking cover
- 20% greater flexibility
- 7 times greater abrasion resistance
- Built to SAE 100R1AT OD dimensions
- 3/8" MPT Swivel x 3/8" MPT Swivel

PART NO.	SIZE	ID	TEMP	PSI	COLOR
8.739-198.0	<b>S</b> 50'	3/8	250°F	4500	Blue
8.739-200.0	<b>S</b> 100'	3/8	250°F	4500	Blue

## HOTSY FUEL FILTER/WATER SEPARATOR



- Extends life of fuel system
- Clear sediment bowl and washable screen
- Drain valve
- Filters gasoline and diesel fuel

PART NO.	DESCRIPTION
8.717-710.0	Filter, Fuel/ Oil Water Separator
8.717-711.0	Replacement Screen

## HOTSY FUEL FILTER/WATER SEPARATOR



- 10 micron filtration
- Spin-on convenience
- Water separation chamber
- 1/4" FPT inlet/outlet
- Easy drain water/sediment bowl

PART NO.	DESCRIPTION
8.749-771.0	Complete Unit

## HOTSY TOUCH-UP PAINT



- Matches the color on your Hotsy
- Comes in aerosol or dab/brush

PART NO.	DESCRIPTION
8.720-519.0	12 oz. Aerosol - Red
8.723-214.0	12 oz. Aerosol - APW Gray



# HOTSY HOSE REELS

**Fully assembled and ready to use!**

Hotsy hose reels were designed for ease of use and durability in commercial pressure washer applications.

Offering 100' and 200' reels in both a fixed base and 360 degree rotating base. The oversized reel holds the advertised length plus leaves additional space reducing the difficulty of reeling hose. The unique extended swivel improves the hose connection and reduces hose wear and stress.



**FEATURES**

- *Rugged heavy-duty construction for commercial applications.*
  - Heavy gauge steel fabrication with durable handle
  - Gloss black powder coating
  - Easy to use brake mechanism reduces unwinding backlash
  - Oversized heavy-duty locking mechanism prevents slippage during reel operation
- *"Flip-Over" hose guide: Allows ease of use from either side of the reel*
- *Oversized: Oversized to easily fit the advertised length of hose. When we say 100' we mean 100+ feet will easily fit.*
- *Swivel design: The reels come with an extended swivel which prevents bends and stress on the hose where it attaches to the reel.*
- *Rotary mount: 360 degree rotation with an oversized heavy-duty locking mechanism. Allows for continual alignment with the hose.*
  - Mount to round or square tubing
- *Fully assembled: Ready to use out of the box. Saves time and money.*
- *2-year warranty on the swivel.*

## HOTSY HOSE REELS

- 5000 PSI
- 325°F
- 100' and 200' fixed base
- 100' and 200' 360 degree rotating base
- High pressure double seal swivels.

PART NO.	DESCRIPTION	LENGTH
8.750-486.0	Pivot Reel	100' x 3/8"
8.750-483.0	Pivot Reel	200' x 3/8"
8.750-478.0	Fixed Based	100' x 3/8"
8.750-481.0	Fixed Based	200' x 3/8"

## HOTSY BRACKET SOCKETS



Universal Mount    Skid Mount    Wall Mount    Base Mount

PART NO.	DESCRIPTION
8.919-430.0	Universal Mount*
8.919-794.0	Skid Mount*
8.919-437.0	Wall Mount*

## HOTSY NON-PIVOT REEL BRACKETS



Universal Bracket    90° Bracket    45° Bracket    Vertical Bracket

PART NO.	DESCRIPTION
8.919-072.0	Bracket, Universal*
8.919-445.0	Bracket, 90°*
8.919-441.0	Bracket, 45°*
8.919-448.0	Bracket, Vertical*



## HOTSY FIXED BASE HOSE REELS & MOUNTING BRACKET OPTIONS



HOT WATER ELECTRIC MODEL	CONNECTOR HOSE*	BRACKET #1 45° ARM	BRACKET #2 90° ARM	BRACKET #3 VERTICAL ARM
555SS	8.918-257.0 (4 ft)	8.919-441.0	8.919-445.0	8.919-448.0
560SS	8.918-261.0 (6 ft)	8.919-441.0	8.919-445.0	8.919-448.0
680SS	8.918-257.0 (4 ft)	8.919-441.0	8.919-445.0	8.919-448.0
790SS	8.918-257.0 (4 ft)	8.919-441.0	8.919-445.0	8.919-448.0
795SS	8.918-257.0 (4 ft)	8.919-441.0	8.919-445.0	8.919-448.0
795SS-208	8.918-257.0 (4 ft)	8.919-441.0	8.919-445.0	8.919-448.0
895SS	8.918-257.0 (4 ft)	8.919-441.0	8.919-445.0	8.919-448.0
800 Series	8.918-261.0 (6 ft)	8.919-441.0	8.919-441.0	8.919-448.0

\* Required to connect hose reel to pressure washer.

## HOTSY 360° PIVOT HOSE REELS & CONNECTOR HOSE OPTIONS



HOT WATER ELECTRIC MODEL	CONNECTOR HOSE*
555SS	8.918-255.0 (3 ft)
560SS	8.918-257.0 (4 ft)
680SS	8.918-257.0 (4 ft)
790SS	8.918-257.0 (4 ft)
795SS	8.918-257.0 (4 ft)
795SS-208	8.918-257.0 (4 ft)
895SS	8.918-257.0 (4 ft)
800 Series	8.918-261.0 (6 ft)

# HOTSY STACKABLE HOSE REELS & ACCESSORIES

Hose reels built specifically for contractors who require flexibility on a job site. Stackable reels are supported on both sides of the central hub to accommodate more aggressive applications, such as trailer-mounted.

\*Patent D739,715S

- Reel and swivel rated up to 6000 PSI and 350°F
- Integrated frame adds protection and stacking ability
- Accommodates hose lengths of up to 100' or 200'
- Ideal for stacking on a trailer
- Heavy-duty powder-coated steel or stainless steel
- Modular design allows user to configure to meet various needs
- Reversible hand-crank and swivel (2-year swivel warranty)



200' Mild Steel Ready-Stack Hose Reel    100' Mild Steel Ready-Stack Hose Reel



Stainless Steel Ready-Stack Hose Reel    See diagram below



**Hose Reel Riser**  
Feeds hose over and around obstacles

**Hose Guide**  
Directs hose back onto reel for a more uniform fit

**Reel Cart System**  
Easily move multiple hoses & reels where needed



**Configured 200' Mild Steel Stackable Hose Reel with Optional Hose Guide and Hose Reel Riser**

**Configured 200' Mild Steel Stackable Hose Reels with Optional Reel Cart System and Hose Guide**

PART NO.	DESCRIPTION
9.801-775.0	100' Mild Steel Hose Reel
9.801-776.0	200' Mild Steel Hose Reel
9.801-777.0	100' Stainless Steel Hose Reel
9.801-778.0	200' Stainless Steel Hose Reel
8.923-415.0	100' Hose Guide
8.923-427.0	200' Hose Guide
8.923-918.0	Wheel Cart
8.923-416.0	Riser

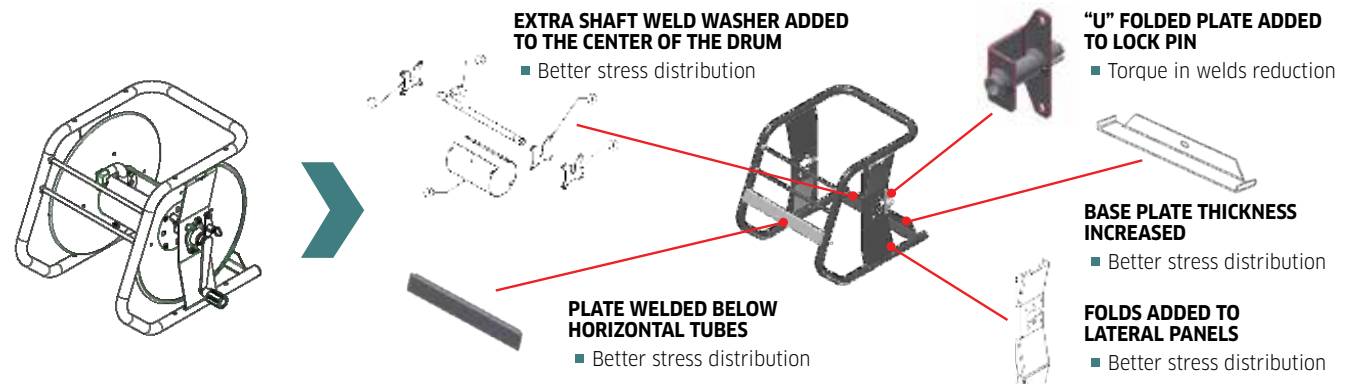



## HOTSY NOZZLES

1/4" male pipe thread nozzles, rated up to 5100 PSI. Hardened stainless steel nozzle insures consistent, accurate orifice size.



NOZZLE SIZE	0° PART NO.	15° PART NO.	40° PART NO.
4.0	8.711-375.0	8.711-377.0	8.711-380.0
4.5	8.711-383.0	8.711-385.0	8.711-388.0
5.0	8.711-389.0	8.711-392.0	8.711-395.0
5.5	8.711-396.0	8.711-398.0	8.711-402.0
6.0	8.711-404.0	8.711-406.0	8.711-411.0
6.5	-	8.711-412.0	8.711-414.0
7.0	8.711-416.0	8.711-417.0	8.711-419.0
7.5	8.711-422.0	8.711-423.0	-
8.0	8.707-723.0	8.711-424.0	8.711-426.0
8.5	8.711-427.0	8.711-429.0	-
9.0	8.711-434.0	8.711-435.0	8.711-438.0
12	-	8.707-766.0	8.707-768.0
15	8.711-447.0	8.711-448.0	8.707-790.0
20	8.707-795.0	8.711-452.0	8.707-804.0
40	-	8.707-824.0	-

## HOTSY ADJUSTABLE FAN NOZZLE

3000 maximum PSI, Vari-fan nozzle easily adjusts from 0° to 80° fan size with a simple twist of the nozzle head.



- 3000 PSI
- 300°F
- 1/4" inlet

PART NO.	ORIFICE
8.712-400.0	3.5
8.712-401.0	4.0
8.712-407.0	4.5
8.712-402.0	5.0
8.712-408.0	5.5
8.712-406.0	6.0
8.717-569.0	6.5
8.712-410.0	7.5
8.717-690.0	Repair Kit

## HOTSY HIGH/LOW ADJUSTABLE FAN NOZZLE

All the features of the variable fan nozzle. Plus with a pull, nozzle lowers pressure for chemical application.



- 3000 PSI
- 200°F
- Low pressure soap injection
- 1/4" inlet

PART NO.	ORIFICE
8.717-576.0	3.0
8.717-570.0	3.5
8.717-571.0	4.0
8.712-404.0	4.5
8.717-572.0	5.0
8.712-403.0	5.5
8.717-575.0	6.0
8.717-573.0	6.5
8.717-574.0	7.5
8.717-691.0	Repair Kit

## HOTSY NOZZLE PROTECTOR



- Fits 1/4" lances
- Protects nozzles from damage

PART NO.	DESCRIPTION
8.717-320.0	1/4" Nozzle Protector

## HOTSY TWIST QUICK COUPLERS



- Precision brass design
- Unrestricted free flow
- 4000 PSI max

### SWIVELS

Designed for 4000 PSI and extended durability. Affordable and rugged all in one.

PART NO.	DESCRIPTION
8.717-562.0	1/4" FNPT
8.707-189.0	3/8" FNPT
8.717-568.0	1/2" FNPT
8.717-561.0	1/4" MNPT
8.717-560.0	3/8" MNPT
8.717-567.0	1/2" MNPT



- Zinc plated
- Hardened steel
- 4000 PSI max

### ZINC PLATED NIPPLES

Hardened steel combined with zinc yellow chromate plating holds up to the harshest environments.

PART NO.	DESCRIPTION
8.717-564.0	1/4" FNPT
8.707-187.0	3/8" FNPT
8.717-566.0	1/2" FNPT
8.717-563.0	1/4" MNPT
8.707-188.0	3/8" MNPT
8.717-565.0	1/2" MNPT

### REPLACEMENT O-RINGS

For Hotsy twist coupler, Buna.

PART NO.	DESCRIPTION
8.717-230.0	Replacement O-ring

## HOTSY ADJUSTABLE NOZZLE

Compact full feature unit weighs only 4.3 oz.



- 3600 PSI
- 10 GPM
- 300°F
- Machined brass body
- Nylon adjustment knob
- 1/4" FPT inlet / outlet

PART NO.	DESCRIPTION
9.802-950.0	Adjustable Nozzle

## HOTSY TWO-GUN TEE COUPLER

Two-Gun Tee Coupler makes switching from one gun to two a snap. 3/8" quick coupler fittings good up to 4000 PSI.



- For use with dual gun systems
- Couples onto outlet nipple
- 3/8" couplers

PART NO.	DESCRIPTION
8.902-421.0	Two Gun Splitter

## HOTSY ST-56 ROLLOVER NOZZLE HEAD



- Brass body
- 3600 PSI
- 8 GPM
- 300°F
- Glass-filled polyamide cover
- 1/4" FPT inlet / outlet

PART NO.	DESCRIPTION
8.712-411.0	Rollover Nozzle Head



# THE HOTSY PUMP

**Engineered for durability and performance.**

Hotsy Pumps featuring NESTechnology™

What is NESTechnology™? It stands for Nested Seal Technology, where the pump actually “nests” the seals of the pump’s high-pressure packing assembly in place, supporting the side walls, and resulting in greatly increased seal life.

The unique technology of the nesting assembly includes high and low-pressure U-shaped seals surrounded by thicker brass pressure rings. This provides better wall support while withstanding higher water temperatures. This results in Hotsy pumps having 3 times the seal life over similar pumps in the industry.

- Extended time between seal replacement, greatly reducing maintenance costs.
- Teflon bronze rings support the U-Seal to prevent premature wear and loss of pressure.
- The low-pressure U-Seal has a unique double lip to provide for greater suction and less chance of water leakage.
- Increased wall thickness of the brass pressure rings resist cracking and provide a solid foundation for the seals.
- The nesting assembly is stronger and holds up better to spikes in water pressure, which occur every time the gun is triggered.
- Existing Hotsy pumps can be upgraded to utilize NESTechnology’s unique nesting assembly. All parts are interchangeable, and fit within the brass manifold.
- Seals are rated for temperatures up to 185°F.

Seals are a wear item in a pump because of the intense pressure they are subjected to. Hotsy’s nested seal technology holds up better, and has improved the seal life by changing the geometry of the packing assembly and providing greater support to the seals. The end result is a high-performance pump with extended service life.

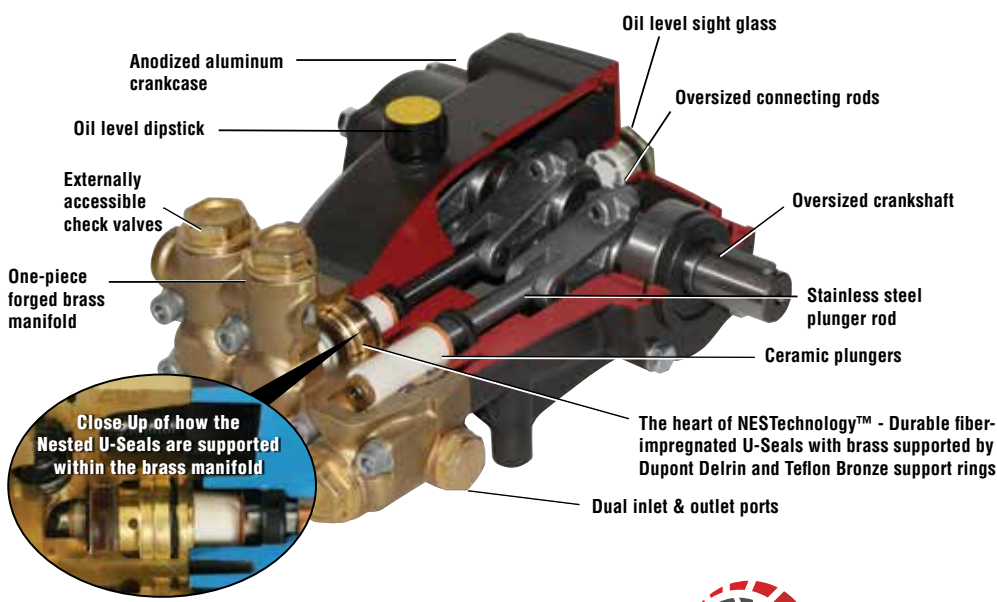
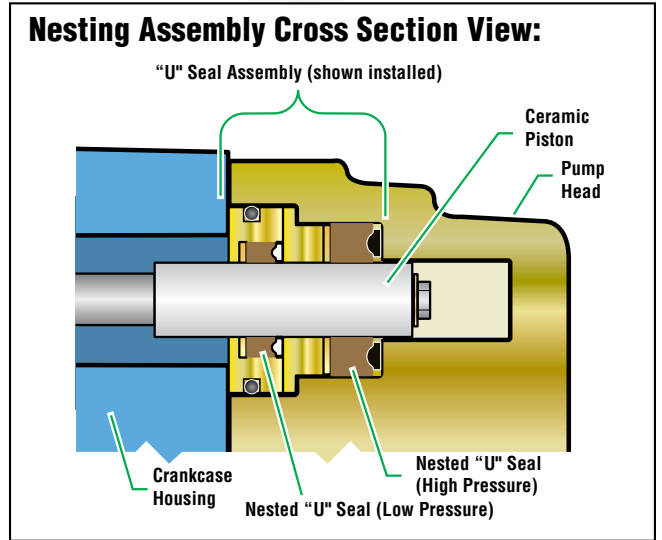

- Four frame sizes: one duplex, and three triplex sizes - small, medium, large
- Externally accessible check valves
- Two inlet and discharge ports facilitate system installation
- Anodized aluminum crankcase
- Polished ceramic plungers reduce seal wear
- Oversized crankshaft and connecting rods
- Heavy-duty roller bearings or heavy-duty tapered roller bearings
- Internally-ported, self-lubricating seals
- Pumps available for pulley, direct or gear-reducer drive
- 7-year warranty on the oil-end of the pump





# HOTSY PUMPS



## DUPLEX SERIES: DIRECT DRIVE



## HS.3 SERIES: DIRECT DRIVE

PART NO.	ORIG. NO.	GPM	PSI	HP	RPM	SHAFT	WEIGHT
8.751-182.0	HS3040G.3	3.0	4000	11.5	3400	1"	23 lbs
8.751-183.0	HS3540G.3	3.5	4000	13.5	3400	1"	23 lbs
8.751-184.0	HS4040G.3	4.0	4000	15.4	3400	1"	23 lbs



## HP SERIES: DIRECT DRIVE

PART NO.	ORIG. NO.	GPM	PSI	HP	RPM	SHAFT	WEIGHT
8.929-273.0	HPP2535G	2.5	3500	6.0	3400	3/4"	16.75 lbs
8.929-271.0	HPP3035G	3.0	3500	7.2	3400	3/4"	16.75 lbs
8.929-272.0		3.0	3500	7.2	3400	1"	18 lbs
8.923-774.0	HP3535G1	3.5	3500	8.4	3400	1"	18 lbs



## HF SERIES: DIRECT DRIVE

PART NO.	ORIG. NO.	GPM	PSI	HP	RPM	SHAFT	WEIGHT
8.923-776.0	HF2030F	2.1	3000	4.3	3450	5/8"	17 lbs
8.929-266.0	HFP2030S	2.1	3000	4.3	1725	5/8"	17 lbs
8.928-275.0	HF2030SL	2.1	3000	4.3	1725	5/8"	17 lbs
8.923-778.0	HF2830F	2.8	3000	5.8	3450	5/8"	17 lbs
8.929-274.0	HFP2830S	2.8	3000	5.8	1725	5/8"	17 lbs
8.923-780.0	HF3530F	3.5	3000	7.2	3450	5/8"	17 lbs



## HX SERIES: BELT DRIVE

PART NO.	ORIG. NO.	GPM	PSI	HP	RPM	SHAFT	WEIGHT
8.920-583.0		5.8	4350	17.3	1740	25mm R	38 lbs
8.920-584.0		8.0	4350	23.8	1740	25mm R	38 lbs
8.920-585.0		9.5	3625	16.4	1740	25mm R	38 lbs
8.920-586.0	HX9536L.2	9.5	3625	23.6	1740	25mm L	38 lbs
8.920-587.0		10.4	3625	23.6	1740	25mm R	38 lbs
8.920-588.0	HX1036L.2	10.4	3625	25.8	1740	25mm L	38 lbs



## HOTSY PUMPS (CONTINUED)



### HB SERIES: BELT DRIVE

PART NO.	ORIG. NO.	GPM	PSI	HP	RPM	SHAFT	WEIGHT
8.929-270.0	HBP3030R	3.0	3000	6.2	1650	24mm	14.5 lbs
8.929-644.0	HBP3030L	3.0	3000	6.2	1650	24mm	14.5 lbs
8.929-269.0	HBP4025R	4.0	2500	6.8	1550	24mm	14.5 lbs
8.923-770.0	HB4025L	4.0	2500	6.8	1550	24mm	14.5 lbs



### HX5450 SERIES: BELT DRIVE

PART NO.	ORIG. NO.	GPM	PSI	HP	RPM	SHAFT	WEIGHT
8.921.659.0	HX5450R	5.4	5000	18.3	1740	24mm R	43 lbs
8.921.660.0	HX5450L	5.4	5000	18.3	1740	24mm L	43 lbs



### HM.3 SERIES: BELT DRIVE

PART NO.	ORIG. NO.	GPM	PSI	HP	RPM	SHAFT	WEIGHT
8.751-179.0		3.5	4000	9.5	1850	24mm R	21 lbs
8.751-180.0		4.8	3500	11.5	1500	24mm R	21 lbs
8.751-181.0		4.8	3500	11.5	1500	24mm L	21 lbs
8.923-100.0		4.0	3000	8.2	1725	24mm R	21 lbs
8.923-101.0		4.0	3000	8.2	1725	24mm L	21 lbs
8.923-165.0		4.0	3000	8.2	1000	24mm R	21 lbs
8.923-166.0		4.0	3000	8.2	1000	24mm L	21 lbs



### HT SERIES: BELT DRIVE

PART NO.	ORIG. NO.	GPM	PSI	HP	RPM	SHAFT	WEIGHT
8.921-718.0		4.5	4000	12.3	1360	25mm R	33 lbs
8.921-719.0		4.5	4000	12.3	1360	25mm L	33 lbs
8.921-720.0		6.0	3600	14.7	1450	25mm R	33 lbs
8.921-721.0		6.0	3600	14.7	1450	25mm L	33 lbs

## FASPUMP QUICK CHANGE PUMP ASSEMBLIES

Includes a pump, unloader, thermal protector, by-pass loop hose, garden hose inlet with filter, and quick connect plug, making them easy to install.



PART NO.	DESCRIPTION	DRIVE	GPM	PSI	RPM	SHAFT
8.924-434.0	Pump Assy, LP3035G, VTR3	Direct	3.0	3500	3400	3.4" Hollow
8.924-435.0	Pump Assy, LP3535G1,	Direct	3.5	3500	3400	1" Hollow
8.924-436.0	Pump Assy, LS4040G.3,	Direct	4.0	4000	3400	1" Hollow
8.924-437.0	Pump Assy, LB3030R, VTR3	Belt	3.0	3000	1650	24mm Solid
8.924-438.0	Pump Assy, , LM3540R.3,	Belt	3.5	4000	1850	24mm Solid
8.924-439.0	Pump Assy, LM3840R.3,	Belt	3.8	4000	1740	24mm Solid

# HOTSY PUMP REPAIR KIT SELECTION CHART

Use the selection chart below to find the correct repair kits for the specific Hotsy Pump Model.

<b>PUMP MODEL</b>	<b>SEAL TYPE</b>	<b>SEAL KIT (QTY/PUMP)</b>	<b>COMPLETE SEAL KIT (QTY/PUMP)</b>	<b>VALVE KIT (QTY/PUMP)</b>	<b>PLUNGER OIL SEAL KIT (QTY/PUMP)</b>	<b>CERAMIC SLEEVE (QTY/PUMP)</b>
			8.725-407.0 (3)	8.717-584.0 (6)		
			8.725-407.0 (3)	8.717-584.0 (6)		
			8.725-407.0 (3)	8.717-584.0 (6)		
			8.725-407.0 (3)	8.717-584.0 (6)		
			8.725-407.0 (3)	8.717-584.0 (6)		
			8.725-407.0 (3)	8.717-584.0 (6)		
			8.725-404.0 (3)	8.717-584.0 (6)		
			8.725-405.0 (3)	8.717-584.0 (6)		
			8.725-401.0 (3)	8.717-584.0 (6)		
			8.725-401.0 (3)	8.717-584.0 (6)		
			8.725-408.0 (2)	8.717-584.0 (4)		
			8.725-408.0 (2)	8.717-584.0 (4)		
			8.717-671.0 (2)	8.717-584.0 (4)		
			8.725-415.0 (3)	8.717-584.0 (6)		
			8.725-407.0 (3)	8.717-584.0 (6)		
			8.725-407.0 (3)	8.717-584.0 (6)		
			8.725-407.0 (3)	8.717-584.0 (6)		
			8.725-415.0 (3)	8.717-584.0 (6)		
			8.725-407.0 (3)	8.717-584.0 (6)		
			8.725-418.0 (3)	8.717-590.0 (6)		
			8.725-407.0 (3)	8.717-584.0 (6)		
			8.725-407.0 (3)	8.717-584.0 (6)		
			8.725-407.0 (3)	8.717-584.0 (6)		
			8.725-407.0 (3)	8.717-584.0 (6)		
			8.725-407.0 (3)	8.717-584.0 (6)		
			8.725-407.0 (3)	8.717-584.0 (6)		
			8.725-407.0 (3)	8.717-584.0 (6)		
			8.725-407.0 (3)	8.717-584.0 (6)		
			8.725-407.0 (3)	8.717-584.0 (6)		
			8.725-407.0 (3)	8.717-584.0 (6)		
			8.725-404.0 (3)	8.717-584.0 (6)		
			8.725-401.0 (3)	8.717-584.0 (6)		
			8.725-404.0 (3)	8.717-591.0 (6)		
			8.725-405.0 (3)	8.717-589.0 (1)		
			8.725-401.0 (3)	8.717-589.0 (1)		
			8.725-357.0 (3)	9.803-936.0 (1)		
			9.804-077.0 (3)	9.803-936.0 (1)		
			8.725-357.0 (3)	9.803-936.0 (1)		
			8.725-355.0 (3)	9.803-936.0 (1)		
			8.725-357.0 (3)	9.803-936.0 (1)		
			8.725-355.0 (3)	9.803-936.0 (1)		
			8.725-357.0 (3)	9.803-936.0 (1)		
			8.725-355.0 (3)	9.803-936.0 (1)		
			8.725-357.0 (3)	9.803-936.0 (1)		
			8.725-355.0 (3)	9.803-936.0 (1)		
			8.725-355.0 (3)	9.803-936.0 (1)		
			8.725-355.0 (3)	9.803-936.0 (1)		
			8.725-355.0 (3)	9.803-936.0 (1)		
			8.725-355.0 (3)	9.803-936.0 (1)		
			8.725-355.0 (3)	9.803-936.0 (1)		
			8.725-355.0 (3)	9.803-936.0 (1)		
			8.725-355.0 (3)	9.803-936.0 (1)		
			9.804-493.0 (3)	9.802-604.0 (1)		
			8.725-407.0 (3)	8.717-584.0 (6)		
			8.725-407.0 (3)	8.717-584.0 (6)		
			8.725-401.0 (3)	8.717-589.0 (1)		

## HOTSY PUMP REPAIR KIT SELECTION CHART (CONTINUED)

Use the selection chart below to find the correct repair kits for the specific Hotsy Pump Model.

PUMP MODEL	SEAL TYPE	SEAL KIT (QTY/PUMP)	COMPLETE SEAL KIT (QTY/PUMP)	VALVE KIT (QTY/PUMP)	PLUNGER OIL SEAL KIT (QTY/PUMP)	CERAMIC SLEEVE (QTY/PUMP)
			8.725-417.0 (3)	8.717-590.0 (6)		
			8.758-087.0 (1)	9.802-603.0 (1)		
			8.758-085.0 (1)	9.802-603.0 (1)		
			8.758-087.0 (1)	9.802-603.0 (1)		
			8.725-417.0 (3)	8.717-590.0 (6)		
			8.758-087.0 (1)	9.802-603.0 (1)		
			8.717-647.0 (3)	8.717-590.0 (6)		
			8.758-087.0 (1)	9.802-603.0 (1)		
			8.758-087.0 (1)	9.802-603.0 (1)		
			8.758-087.0 (1)	9.802-603.0 (1)		
			8.725-365.0 (3)	9.802-608.0 (1)		
			8.725-365.0 (3)	9.802-608.0 (1)		
			9.804-493.0 (3)	9.802-604.0 (1)		
			9.804-493.0 (3)	9.802-604.0 (1)		
			8.725-365.0 (3)	9.802-608.0 (1)		
			8.725-365.0 (3)	9.802-608.0 (1)		
			8.758-085.0 (1)	9.802-603.0 (1)		
			8.758-087.0 (1)	9.802-603.0 (1)		
			8.725-407.0 (1)	8.717-584.0 (6)		
			8.725-407.0 (1)	8.717-584.0 (6)		
			8.725-407.0 (1)	8.717-584.0 (6)		
			8.725-407.0 (1)	8.717-584.0 (6)		
			8.725-407.0 (1)	8.717-584.0 (6)		
			8.758-087.0 (1)	9.802-603.0 (1)		
			8.758-087.0 (1)	9.802-603.0 (1)		
			8.758-087.0 (1)	9.802-603.0 (1)		
			8.758-087.0 (1)	9.802-603.0 (1)		
			8.757-936.0 (1)	8.753-349.0 (1)		
			8.757-936.0 (1)	8.753-349.0 (1)		
			8.757-937.0 (1)	8.753-349.0 (1)		
			8.757-937.0 (1)	8.753-349.0 (1)		
			8.758-061.0 (1)	8.753-824.0 (1)		
			8.758-061.0 (1)	8.753-824.0 (1)		
			8.758-081.0 (1)	8.754-859.0 (1)		
			8.758-081.0 (1)	8.754-859.0 (1)		
				8.754-859.0 (1)		
				8.754-859.0 (1)		
			8.758-081.0 (1)	8.754-859.0 (1)		
			8.758-083.0 (1)	8.754-859.0 (1)		
			8.758-081.0 (1)	8.754-859.0 (1)		
			8.758-083.0 (1)	8.754-859.0 (1)		
				8.754-859.0 (1)		
				8.754-859.0 (1)		
			8.758-083.0 (1)	8.754-859.0 (1)		
			8.758-083.0 (1)	8.754-859.0 (1)		
			8.758-083.0 (1)	8.754-859.0 (1)		
			8.758-083.0 (1)	8.754-859.0 (1)		
			8.758-083.0 (1)	8.754-859.0 (1)		
				8.754-859.0 (1)		
				8.754-859.0 (1)		

## HOTSY PUMP REPAIR KIT - SEAL KIT

PART NO.	QTY NEEDED PER PUMP
8.725-362.0	1
8.916-488.0	1
8.916-487.0	1
8.725-364.0	1
8.717-623.0	1
8.725-360.0	1
8.725-356.0	1
9.804-076.0	1
8.725-354.0	1
9.804-492.0	1

PART NO.	QTY NEEDED PER PUMP
8.725-358.0	1
8.717-646.0	1
8.752-844.0	1
8.753-821.0	1
8.754-856.0	1
8.759-015.0	1
8.754-860.0	1
8.759-031.0	1

## HOTSY PUMP REPAIR KIT - COMPLETE SEAL KIT

PART NO.	QTY NEEDED PER PUMP
8.725-407.0	3
8.725-404.0	3
8.725-405.0	3
8.725-401.0	3
8.725-408.0	2
8.717-671.0	2
8.725-415.0	3
8.725-418.0	3
8.725-357.0	3
9.804-077.0	3
8.725-355.0	3
9.804-493.0	3

PART NO.	QTY NEEDED PER PUMP
8.725-417.0	3
8.758-087.0	1
8.758-085.0	1
8.717-647.0	3
8.725-365.0	3
8.725-407.0	1
8.757-936.0	1
8.757-937.0	1
8.758-061.0	1
8.758-081.0	1
8.929-348.0	1
8.758-083.0	1
8.758-218.0	1

## HOTSY PUMP REPAIR KIT - VALVE KIT

PART NO.	QTY NEEDED PER PUMP
8.717-584.0	6
8.717-590.0	6
8.717-591.0	6
8.717-589.0	1
9.803-936.0	1
9.802-604.0	1

PART NO.	QTY NEEDED PER PUMP
9.802-603.0	1
9.802-608.0	1
8.753-349.0	1
8.753-824.0	1
8.754-859.0	1



## HOTSY PUMP REPAIR KIT - PLUNGER OIL SEAL KIT

PART NO.	QTY NEEDED PER PUMP
9.802-609.0	1
8.717-585.0	1
8.717-587.0	1
9.803-937.0	1

PART NO.	QTY NEEDED PER PUMP
9.802-606.0	1
9.803-937.0	1

## HOTSY PUMP REPAIR KIT - CERAMIC SLEEVE KIT

PART NO.	QTY NEEDED PER PUMP
8.717-617.0	3
8.717-586.0	3
8.717-601.0	3
9.802-614.0	3
8.717-670.0	2
8.717-632.0	3
9.803-935.0	3
9.803-934.0	3
9.802-629.0	3
8.933-023.0	3

PART NO.	QTY NEEDED PER PUMP
9.803-934.0	3
8.751-237.0	3
8.751-238.0	3
8.752-838.0	3
8.752-938.0	3
8.752-939.0	3
8.753-823.0	3
8.754-858.0	3
8.754-862.0	3



## HOTSY PUMP TOOL KITS

A must for every service department. Save time using the right tool for the job. The Hotsy Pump Tool Kit includes:

- Plastic Covered Thin Blade Screwdriver
- 6mm Allen Wrench
- 14mm Allen Wrench
- Plastic Hammer
- Seal Extractor
- Two Piece Insert for Sleeves
- Two Part Seal Insert for Plunger Rods
- Crankshaft Seal Insert
- Two Part Seal Insert for Plunger Rods
- Crankshaft Seal Insert
- Plastic Tool Box
- Pliers
- Seal Extractor



PART NO.	DESCRIPTION
9.802-953.0	13 Piece Hotsy Pump Tool Kit
9.802-568.0	Pliers, Seal Extractor

## HOTSY UNLOADERS



- Head mount or remote
- Lock device
- Hotsy proven performers

8.715-491.0

8.715-505.0

PART NO.	DESCRIPTION	GPM	PSI
8.715-498.0	XSM without Knob 1/4 Bypass	6.6	4500
8.707-351.0	XSM without Knob 3/8 Bypass	6.6	2500
8.715-502.0	H/M Duplex Pumps	6.6	1000
8.715-500.0	H/M High Temp O-rings	6.6	600
8.715-491.0	H/M Sml & Med Triplex Pumps	6.6	3000
8.715-494.0	H/M Sml & Med Triplex with Hi Flow Banjo	6.6	3000
8.715-493.0	H/M SST Pumps	6.6	3000
8.715-490.0	H/M SST with Hi Flow Banjo Bolts	6.6	3000
8.755-611.0	VBS 210 with Knob, 1/4" Bypass	6.6	3000
8.715-504.0	LG with Knob	6.6	2200
8.715-503.0	LG with Knob	6.6	3000
8.715-505.0	LG with Knob (without Spacer)	6.6	2900
8.715-508.0	XLG with Knob	13.2	3000
8.753-011.0	VB56 with Knob	8	3650
9.802-361.0	VB55 with 1/8" Bore for easy start	8	3200
9.803-899.0	VBA35 for Hotsy HG, HD, HE	6.6	3500
9.803-900.0	VBA35 for Hotsy HM,HS	6.6	3500

## HOTSY MAINTENANCE KIT

PART NO.	DESCRIPTION
8.756-590.0	NHD Pump Series Tool Kit for HB, HP & HP1

## HOTSY PUMP OIL



- Formulated to exceed the factory specifications for HOTSY and other high pressure pumps.
- Non-detergent, non-foaming

PART NO.	DESCRIPTION
8.923-422.0	 32 oz. Bottle

## HOTSY DOWNSTREAM CHEMICAL INJECTORS

Applies detergent while by-passing vital machine components.



Fixed Injector

Adjustable Injector

PART NO.	DESCRIPTION
<b>Adjustable</b>	
9.802-956.0	Hot Water 2.1mm 3/8" M x 3/8" M
8.709-428.0	Cold Water 2.1mm 3/8" M x 3/8" M
8.709-429.0	Cold Water 2.3mm 3/8" M x 3/8" M
<b>Fixed - Cold Water</b>	
8.709-419.0	1.8mm 3/8" F x 3/8" M
9.802-957.0	2.1mm 3/8" M x 3/8" M
8.709-421.0	2.1mm 3/8" F x 3/8" M
8.709-422.0	2.1mm 3/8" qc skt x 3/8" qc plug
8.709-420.0	2.3mm 3/8" F x 3/8" M
8.709-423.0	1.8mm 3/8" M x 3/8" M 2-3 GPM Ceramic Check
8.709-424.0	2.1mm 3/8" M x 3/8" M 3-5 GPM Ceramic Check
<b>Repair Kits</b>	
8.718-494.0	Repair Kit 722429, 722430
8.718-495.0	Repair Kit 873580,873582,873594, 22400,722436,875760

## HOTSY INLET CHEMICAL INJECTOR



- Two adjusting knobs for incoming water pressure and detergent metering

PART NO.	DESCRIPTION
9.803-275.0	HotSyt Dual-Adjusting Injector
8.700-290.0	Repair Kit

## HOTSY PRESSURE RELIEF VALVES



8.718-496.0



8.707-332.0

PART NO.	PSI
8.707-337.0	500
8.707-332.0	1000
8.707-336.0	1500
8.718-496.0	2000
8.707-274.0	2200
8.707-335.0	2500
8.711-231.0	3000
8.707-334.0	3500
8.707-258.0	150 PSI/ 210°F

## HOTSY FLOAT TANK



9.804-042.0

- Heavy 3/16" durable plastic

PART NO.	DESCRIPTION
9.804-042.0	2.5 gal without Adapter
8.706-642.0	4.0 gal with Cover

## HOTSY THERMOSTATS



8.712-191.0



8.716-102.0

PART NO.	DESCRIPTION
8.712-191.0	240°F 1M Probe
<b>For use with above:</b>	
8.712-190.0	Mounting Plate
8.718-779.0	Screws (2), Mounting Plate
8.712-189.0	Dial
8.707-286.0	Well
9.804-564.0	Screw, Well
8.716-102.0	Temp Control Bulb 200°F
8.712-199.0	Temp Control with Bulb
8.712-200.0	-100 + 400 Fenwall
8.712-206.0	Switch Therm NC 140°F

## HOTSY FLOW SWITCH



PART NO.	DESCRIPTION
8.716-139.0	FS 1 McDonnell - 1/2" FPT
8.716-138.0	FS 6 McDonnell - 1" FPT

## HOTSY PRESSURE SWITCH



8.716-129.0

- Activated pressure 375 PSI

PART NO.	DESCRIPTION	PSI	AMP	VOLTAGE
8.716-129.0	Pressure Switch, 3/8" NPT	4000	15	250
8.712-267.0	Pressure Switch, 1/4" MPT	5800	15	250
8.717-667.0*	Repair Kit-Seal			
8.717-668.0*	Repair Kit-Plunger			
8.717-256.0*	Micro Switch			

\* Repair parts only fit the 8.716-129.0.

## HOTSY COILS



- Heavy-duty schedule 80 carbon steel pipe
- Best warranty in the industry
- Sized to water flow for maximum heat rise
- Wound specifically for oil and gas fired applications

PART NO.	DESCRIPTION
<b>Oil Fired</b>	
8.925-219.0	16", fits 444/550/660, 555, 560, 781, 871, 921, 965 Series
8.911-493.0	fits 900/1000, 1400 Series
8.911-497.0	fits 3Z663/5Z021 Series
8.925-221.0	fits 800E/950/810, 1260, 70, 80, 90 Series
8.911-499.0	fits 530, Sheetmetal Frame
8.911-500.0	fits 520/540 Series
8.911-494.0	fits 5000/9450, 5645, 5700 Series
8.911-502.0	fits 800 30" HGT
8.911-505.0	fits 530/610 Series, Angle Frame
<b>Gas/Oil Fired</b>	
8.911-496.0	28" fits 9460 Series
<b>Gas Fired</b>	
8.925-215.0	fits 900/1000, 1400 Series
8.911-501.0	fits 611/530 Series
8.911-495.0	fits 5000 Series, 9452
8.911-503.0	fits 800 30" HGT
8.911-504.0	fits 800 27" HGT
8.911-976.0	16" fits 551, 558, 559 Series
8.911-996.0	fits 771, 772

## HOTSY COIL INSULATION



- Refractory Grade Ceramic
- Retains heat inside coil for better fuel efficiency and paint protection

**8.717-441.0**

PART NO.	DESCRIPTION
8.717-412.0	Cerafelt 24 x 56
8.717-413.0	Cerafelt 6 x 56
8.717-451.0	Cerafelt 1/2 x 24, Bulk/sqft
8.717-452.0	Cerafelt 1 x 24, Bulk/sqft
8.717-414.0	Fiberglass 18 OD x 10.3 ID
8.717-442.0	Fiberglass 18 OD x 8.0 ID
8.717-446.0	Fiberglass 29 x 58
9.802-908.0	Fiberglass 10 x 52
8.717-438.0	Fiberglass 22.5 x 52
9.802-903.0	Fiberglass 16 OD x 4.5
9.802-904.0	Fiberglass 16 OD x 8.3
8.717-445.0	Fiberglass 18 OD x 10
8.717-450.0	Fiberglass 8 x 17.5
9.802-587.0	Fiberglass TBG 50 ID
8.717-449.0	Fiberglass 16 OD x 10
8.717-441.0	Tophead 18 OD x 4.0 ID

## HOTSY DETERGENT FLOW METER



- 100 PSI working pressure
- 150°
- Measures detergent / water flow ratio

PART NO.	DESCRIPTION
8.712-139.0	Up to 100 PSI @ 150°F

## WAYNE BURNERS

Wayne Combustion has been building quality burners since 1928. They are known in the marketplace for superior reliability and ultra-high efficiency. The Wayne Burners have the following features:



- Lower Emissions
- Improved Efficiencies
- Positive flame retention
- Controlled Flame Pattern
- Low Nozzle Temperatures
- High static pressure overcomes adverse draft conditions for a better air/oil mixture

PART NO.	DESCRIPTION	OPERATING VOLTAGE	CONE	FUEL PUMP SOLENOID VOLTAGE
8.756-181.0	MSR 3.75 1T	120V	6A	120V
8.756-253.0	MSR 3.75 1T	120V	7A	120V
8.756-254.0	MSR 3.75 1T	230V	7A	230V
8.756-413.0	EHASR 2T	120V	4A	120V
8.756-456.0	EHASR 1T	230V	7A	24V
8.756-480.0	EHASR 2T	12VDC	4A	12VDC
8.756-655.0	MSR 1T	12V	3A	12VDC
8.756-681.0	EHASR 1T	12VDC	4A	12V
8.756-703.0	EHASR 1T	120V	7A	120V
8.756-736.0	EHASR 2T	12VDC	4A	12VDC
8.756-756.0	EHASR 1T	12VDC	3A	12VDC
8.756-890.0	EHASR 2T	12VDC	4A	12V
8.756-921.0	EH 1.75 1T	120V	3.56" ID Flamelock	120V
8.756-922.0	EH 1.75 1T	230V	3.56" ID Flamelock	120V
8.754-264.0	Vertical Burner M/L	12VDC	3.73" ID Flamelock	12V
8.754-265.0	Vertical Burner M/L	12VDC	3.73" ID Flamelock	12V
8.754-792.0	Vertical Burner M/L	12VDC	3.73" ID Flamelock	12V
8.754-793.0	Vertical Burner M/L	12VDC	3.73" ID Flamelock	12V

## WAYNE BURNER REPLACEMENT PART CROSS REFERENCE CHART

PART NO.	DESCRIPTION	FUEL PUMP	IGNITOR	BURNER MOTOR	BURNER FAN	COUPLING
8.756-181.0	BURNER, MSR 3.75 120V 1T 120V S	8.756-290.0	8.700-803.0	8.756-292.0	8.700-728.0	8.700-822.0
8.756-253.0	Burner MSR 3.75 120V 1T7A 120 V S	8.756-290.0	8.700-803.0	8.756-292.0	8.700-728.0	8.700-822.0
8.756-254.0	BURNER, MSR 3.75 230V 1T 230V S	8.700-760.0	8.756-324.0	8.717-830.0	8.700-728.0	8.700-822.0
8.756-413.0	BURNER, EHASR 120V 2T 120V S	8.700-760.0	8.700-802.0	8.756-436.0	8.756-438.0	8.700-776.0
8.756-456.0	BURNER, EHASR 230V 1T 24V S	8.756-437.0	8.756-291.0	8.756-294.0	8.756-677.0	8.700-776.0
8.756-480.0	BURNER, EHASR 12VDC DO 2T 12VDC S	8.756-437.0	9.107-507.0	8.756-716.0	8.756-726.0	8.756-715.0
8.756-655.0	BURNER, MSR 12V 1T 12V S DC	8.756-437.0	9.107-507.0	8.700-739.0	8.756-674.0	8.700-721.0
8.756-681.0	BURNER, EHASR 12VDCDO 1T 12V S	8.756-437.0	9.107-507.0	8.756-716.0	8.756-674.0	8.756-715.0
8.756-703.0	BURNER, EHASR 120V 1T 120V S	8.756-290.0	8.700-802.0	8.756-293.0	8.756-677.0	8.700-776.0
8.756-736.0	BURNER, EHASR 12VDC 1T 12VDC SOL	8.756-437.0	9.107-507.0	8.756-716.0	8.756-730.0	8.756-715.0
8.756-756.0	BURNER, EHASR 12VDCDO 1T 12VDC S	8.756-437.0	9.107-507.0	8.756-716.0	8.756-730.0	8.756-715.0
8.756-890.0	BURNER , EHASR 12VDC DO 2T 12V S	8.756-437.0	9.107-507.0	8.756-716.0	8.756-726.0	8.756-715.0
8.756-921.0	BURNER, EH 1.75 120V 1T 120V S	8.717-814.0	8.700-802.0	8.756-436.0	8.756-438.0	8.700-776.0
8.756-922.0	BURNER, EH 1.75 230V 1T 120V S	8.717-814.0	8.700-802.0	8.756-745.0	8.756-438.0	8.700-776.0
8.754-264.0	BURNER, WAYNE, EH, 12VDC, 10GPM	8.717-814.0	9.107-507.0	8.700-739.0	8.756-856.0	8.756-715.0
8.754-265.0	BURNER, WAYNE, EH, 12VDC 6-8 GPM	8.717-8.14.0	9.107-507.0	8.700-739.0	8.756-856.0	8.756-715.0
8.754-792.0	BURNER, WAYNE, EH, 12VDC, 6GPM	8.717-814.0	9.107-507.0	8.700-739.0	8.756-726.0	8.756-715.0
8.754-793.0	BURNER, WAYNE, EH, 12VDC, 5GPM	8.717-814.0	9.107-507.0	8.700-739.0	8.756-726.0	8.756-715.0

## BURNER REPLACEMENT PARTS

### Replacement Parts, Wayne

PART NO.	DESCRIPTION
8.700-822.0	FLEX COUPLING-F/307007 12V
8.700-776.0	COUPLING 5/16 x 1/2"FS
8.700-721.0	COUPLING FOR 079021X
8.756-715.0	COUPLING, "E" DC
8.756-438.0	FAN - 4.00"W X 6.25"D 1/2" BORE
8.756-674.0	FAN, 3.44"W X 4.25"D 5/16" BORE
8.756-730.0	FAN, 3.44"W X 4.75"D 5/16" BORE
8.756-726.0	FAN, 3.44"W X 5.25"D 5/16" BORE
8.756-677.0	FAN, 3.50"W X 5.75"D 1/2"BORE
8.700-728.0	BLOWERWHEEL EG1/MSR3.44x4.25STAR MET MTR
8.700-760.0	FUEL PUMP, SUNTEC A2VA-3106 230V SOL
8.756-290.0	FUEL PUMP, WCS - COMBO/W SOLENOID 120V
8.717-814.0	FUEL UNIT, SUNTEC A2VA-7916
8.756-437.0	PUMP - COMBO/W SOLENOID 12V/24V

PART NO.	DESCRIPTION
9.107-507.0	IGNITOR
8.700-803.0	IGNITOR, 120V, BACK/M-MSR MOUNT
8.700-802.0	IGNITOR, 120V, SIDE/EH-EHA MOUNT
8.756-291.0	IGNITOR, BURNER, "E" 240 50-60
8.756-324.0	IGNITOR, BURNER, "M" 240 50-60
8.756-436.0	MOTOR, 1/4 120V 50-60HZ
8.757-632.0	Kit, Motor, 12V
8.717-830.0	MOTOR, 1/8HP 1PH 230V 3450RPM
8.756-293.0	MOTOR, BURNER, 1/5 120V 50-60HZ
8.756-294.0	MOTOR, BURNER, 1/5 230V 50-60HZ
8.756-292.0	MOTOR, BURNER, 1/7 HP 120/60
8.700-739.0	BURNER MOT 12V-WH MSR DC FASCO

### Replacement Parts, Hotsy

PART NO.	DESCRIPTION
8.919-050.0	Burner Housing Assembly - S
8.752-865.0	Burner Housing Assembly - M/L
8.700-758.0	Suntec Fuel Pump, 12-24V Sol
8.754-706.0	Suntec Fuel Pump, OL35, 120V Sol
8.754-707.0	Suntec Fuel Pump, OL35, 230V Sol
8.750-517.0	Burner Motor, 1/6 HP, 115V - S
8.750-518.0	Burner Motor, 1/6 HP, 230V - M/L
8.751-074.0	Burner Motor, 1/7 HP, 12VDC, Ametek
8.752-930.0	Burner Motor, 1/4 HP, 115V with cap - M/L
8.752-931.0	Burner Motor, 1/4 HP, 230V with cap - M/L
8.752-933.0	Burner Motor, 1/5 HP, 13.5 VDC - M/L
8.752-932.0	Burner Motor, 1/7 HP, 115V - M/L
8.750-543.0	Flex Coupling, 1/2" x 5/16"
8.753-061.0	Flex Coupling, 1/2" x 5/16" x 3 7/8"L
8.753-062.0	Flex Coupling, 5/16" x 5/16" x 3 7/8"L
8.750-520.0	Fan, 1/2 Bore - S
8.751-072.0	Fan, 5/16" Bore - S
8.752-928.0	Fan, 6.25 x 4.25 x 1/2 Bore - M/L
8.752-929.0	Fan, 6.25 x 4.25 x .313 Bore - M/L
8.750-547.0	Connector, 37 Degree Flare, 1/8" NPT, Long
8.750-545.0	Connector, 37 Degree Flare, 1/8" NPT
8.749-000.0	Fuel Line Assembly - S

PART NO.	DESCRIPTION
8.752-934.0	Fuel Line Assembly - M
8.753-055.0	Fuel Line Assembly - L
8.750-539.0	Gasket, flange
8.750-526.0	Gun, Electrode / Nozzle, 3"
8.750-525.0	Gun, Electrode / Nozzle, 1"
8.750-778.0	Electrode Ignition
8.919-114.0	Burner Ignitor, 120V
8.919-115.0	Burner Ignitor, 230V
8.919-116.0	Burner Ignitor, 12VDC
8.918-454.0	Junction Box Gasket - S
8.752-922.0	Junction Box Gasket - M/L
8.920-654.0	Junction Box Cover - M/L
8.750-542.0	Junction Box Cover - S
8.751-342.0	Electrode, Ignition, DC
8.750-762.0	Coil, Solenoid, 230V - S
8.750-763.0	Coil, Solenoid, 115V - S
8.750-764.0	Coil, Solenoid, 12-24V - S
9.802-640.0	Coil, Solenoid, 120V - M/L
9.802-641.0	Coil, Solenoid, 230V - M/L
8.700-794.0	Coil, Solenoid, 12-24V - M/L

## HOTSY PRODUCT MIXING STATIONS



Ball valve chemical proportioner for accurately diluting a chemical concentrate to the required ratio and for filling any sized container with diluted, ready-to-use chemical solution. Venturi injection system uses city water pressure to draw and blend chemical concentrate into the water stream to create an accurately diluted solution. Ball valve activation allows for hands-free dispensing.

PART NO.	DESCRIPTION
8.755-141.0	Single Product Mix - Low Flow
8.755-142.0	Single Product Mix - High Flow
8.755-143.0	Dual Product Mix - Low Flow
8.755-144.0	Dual Product Mix - High Flow

## HOTSY ULTIMATE FOAMER WITH GAUGES



A medium volume foam applicator for projecting foaming chemicals on to any surface up close or at a distance. This venturi injection system uses city water pressure to draw and blend chemical concentrate into the water stream to create an accurately diluted solution.

PART NO.	DESCRIPTION
8.755-149.0	Ultimate Foamer

## HOTSY INTERNAL TANK FOAMERS



Tank Foamer is a low-volume foam applicator with an all stainless steel cart assembly for applying ready-to-use foaming chemicals. Connect compressed air to pressurize the 316L stainless steel tank and to inject air into the solution to greatly increase volume and coverage ability.

PART NO.	DESCRIPTION
8.755-145.0	5-Gallon Tank Foamer
8.755-146.0	16-Gallon Tank Foamer

## HOTSY HV FOAMER WITH GAUGES



The HV Foamer is a high volume foam applicator for projecting foaming chemicals on to any large surface. Foam is projected through a discharge hose and fan nozzle at distances up to 15 feet.

PART NO.	DESCRIPTION
8.755-150.0	HV Foamer

## HOTSY POLY TANK 2-WHEELED FOAMER



The Portable 2-Wheel 20 Gallon LF Foamer is a "low volume" foam applicator for projecting ready-to-use foaming chemicals on to any surface up close or at distances up to 9 feet. Features stainless steel cart.

PART NO.	DESCRIPTION
8.755-147.0	20-Gallon Poly Tank Foamer

## HOTSY 32 OZ. COMPACT AIRLESS FOAMER



Medium volume hose-end foam gun for diluting and applying foaming chemicals to any surface. Uses standard city water pressure to draw chemical concentrate from the attached bottle and blend it into the water stream. The accurately diluted solution creates a clinging, wet foam which is then projected on to any surface up close or at distances up to 12 ft.

PART NO.	DESCRIPTION
8.755-151.0	Compact Airless Foamer



## HOTSY DRUM STICKS AND TOTE STICKS

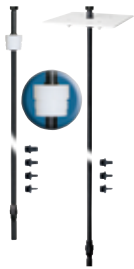

Chemical pick-up assembly to draw chemical solution directly from a drum or tote. Comes complete with a Hastelloy chemical strainer, polypropylene chemical check valve and a selection of polypropylene hose barbs to connect to the most common sizes of hose or tube.

PART NO.	DESCRIPTION
8.755-139.0	Drum Stick Pick Up Assy - 33"

## HOTSY UNI-BODY COMBO DEMO FOAMER



A combination foam / spray applicator for demonstrating foaming or non-foaming chemicals being applied to any surface. Use the foam wand and nozzle for rich, clinging foam, the airless foam wand to demonstrate without compressed air, or use the spray nozzle to apply chemicals as a fan pattern spray.

NOTE: Special order.

PART NO.	DESCRIPTION
8.755-152.0	Uni-Body Combo Foamer

## HOTSY HAND HYGIENE SPRAY DISPENSERS



Heavy-duty, stainless steel hand sanitizer or soap dispenser; when foot pedal is pressed, the system draws a set amount of ready-to-use chemical and dispenses it directly into the users hand. No electricity or batteries are required.

NOTE: Optional one gallon jug rack pictured.

PART NO.	DESCRIPTION
8.755-136.0	Spray Dispenser, Wall Mount
8.755-137.0	Spray Dispenser, Floor Mount

## HOTSY CITY WATER PRESSURE / FLOW TEST KIT



Connects to a standard male garden hose fitting. Provides quick confirmation of available water pressure and flow rate. Can also be mounted in-line with installed equipment to determine operational water pressure. \*Special order.

PART NO.	DESCRIPTION
8.755-148.0	Water Flow Test Kit

## HOTSY TIMED ENTRYWAY FOAM SANITIZER

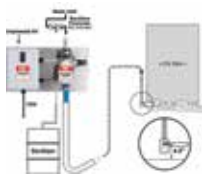

An automated foam applicator for projecting sanitizing chemicals on to floors of 3' wide walk doors to prevent cross contamination. When activated, this venturi injection system uses city water pressure to draw and blend chemical concentrate into the water stream to create an accurately diluted solution.

PART NO.	DESCRIPTION
8.755-140.0	Timed Entry Way - 3' door

## SURFACE CLEANERS



### SURFACE CLEANERS - A+ - 21" & 24"

Fast, even cleaning for large flat surfaces. Quickly cleans concrete, asphalt, and it removes grime and deposits from tennis courts, ramps and decks. Also great for factory and semi-trailer floors and drive-thrus. Cleans better and faster than a spray wand alone, with no striping. Use with hot or cold water and handles water up to 212°F to disinfect bathrooms and kitchens. Safety lock prevents accidental spraying.



- Two Spinning Nozzles 'Floats' Cleaner Above the Ground
- Circular Design for Zero Wall Clearance
- Stainless-steel Housing and Handle
- Universal Inlet Fitting Kit to Accommodate All Common Configurations
- Reduces Overspray on Walls, Landscaping and Operator
- Two #2.0, 1/8" Nozzles (for machines up to #4.0 nozzles), 25° Nozzles Rated up to 8.0 GPM and 4000 PSI
- Requires at Least 3.0 GPM, 2000 PSI



PART NO.	DESCRIPTION
8.753-572.0 	A+SC21 Rotary Surface Cleaner, 21"
8.753-573.0 	A+SC24 Rotary Surface Cleaner, 24"
8.753-597.0	Swivel for 21" and 24"
8.921-834.0	Spray Gun Kit for A+SC 21 & A+SC24 Includes: Screw M6X30, 1/4" Quick Connect, Sleeve, Trigger Gun
8.921-845.0 	Caster Kit for A+SC 21 & A+SC24 Includes: Nut M6, Caster Spacer, Caster Wheel

### SURFACE CLEANERS - ECONOMY - 8" & 15"

- PSI: 4000
- Min: 2 GPM
- Max: 10.5 GPM
- Temperature: 180°F
- Includes 2 1/4 Size 2.5 Nozzle
- 15" Surface Cleaner: 1/4 QC Male Plug Inlet
- 8" Surface Cleaner: 1/4 FPT



9.112-967.0



9.112-968.0

PART NO.	DESCRIPTION
9.112-967.0	15" Surface Cleaner with Wheels
9.112-968.0	8" Stainless-steel Surface Cleaner with Handle
<b>REPAIR KITS</b>	
9.113-078.0	Swivel (for 9.112-967.0)
9.113-080.0	Swivel (for 9.112-968.0)
9.113-079.0	Spraybar (for 9.112-967.0)
9.113-081.0	Spraybar (for 9.112-968.0)
9.113-097.0	Caster Wheel (for 9.112-967.0)
9.113-732.0	Brush, 8" ( for 9.112-968.0)



**SURFACE CLEANERS - GP - FLAT 12", 18" & 20"**



**DFSCP12  
HANDHELD SURFACE CLEANER**

- PSI: 3500
- GPM: 6.5
- Temperature: 180°F
- Inlet M22 Male



**DCFSCP  
SURFACE CLEANER, 18" AND 20"**

- PSI: 4000
- GPM: 8.0
- Temperature: 180°F
- Inlet 3/8" FPT
- Includes 1/4" 2.0 Nozzle



PART NO.	DESCRIPTION
9.112-957.0	DFSCP12 GP Surface Cleaner, 12" 3500 PSI Handheld Flat ABS, Complete Assembly
9.112-958.0	DCFSCP18GZ GP Surface Cleaner, 18" 4000 PSI Brush Skirt ABS, 2-Arm, Zerk Fitting, Compensating Gun
9.112-959.0	DCFSCP20GZ GP Surface Cleaner, 20" 4000 PSI Brush Skirt ABS, 2-Arm, Zerk Fitting, Compensating Gun
<b>REPAIR KITS FOR DCFSCP</b>	
9.112-960.0	Trigger Gun Replacement
9.112-961.0	Spraybar 20" with Nozzles (for DCFSCP20)
9.112-962.0	Spraybar 18" with Nozzles (for DCFSCP18)
9.112-963.0	Swivel, Greaseable (for DCFSCP)
9.112-964.0	Swivel Repair Kit, Greaseable (for DCFSCP)

**SURFACE CLEANERS - VAC RECOVERY**



- PSI: 4000 PSI
- GPM: 10.5
- Temperature: 210°F
- 1/4 " 2.5 Nozzle
- Universal Inlet Fitting Kit to Accommodate All Common Configurations
- Water Recovery with use of vacuum

PART NO.	DESCRIPTION
9.113-972.0	Vac Recovery Surface Cleaner

## SURFACE CLEANERS - WHISPER WASH FLAT

### THE "MAXIMA 36"

- PSI: 2000 - 4000
- GPM: 4-10
- Temperature: 212°F
- RPM: 2500
- Portable Breakaway Handle
- Uses 1/4" Nozzle
- Dimensions: 36" Cover, 77" Handle
- Weight: 37 lbs.



### THE "BIG GUY"

- PSI: 2000 - 4000
- GPM: 4.0 - 10.0
- Temperature: 212°F
- Powder-Coated Aluminum Housing
- Oversized, Self-lubricating Twin Thrust Bearings
- 10" Pneumatic Tires, 4" Caster
- Crafted with Durable Stainless-steel and Aircraft Aluminum
- Uses 1/4" Nozzle
- Choice of 2 or 4 Nozzles
- Dimensions: 28" x 44" x 12"
- Weight: 48 lbs.



PART NO.	DESCRIPTION
8.710-089.0	Maxima 36
8.710-074.0	Whisper Wash Big Guy 2 Nozzles
8.710-075.0	Whisper Wash Big Guy 4 Nozzles
9.109-608.0	Surface Cleaner In-Line Water Filter for Handle
<b>REPAIR KITS</b>	
8.750-604.0	Swivel, Complete Big Guy and Classic
8.701-879.0	Repair Kit, Seal, Big Guy and Classic
8.701-874.0	Spraybar, 4 Nozzle, Big Guy
8.701-876.0	Spraybar, 2 Nozzle, Big Guy
8.701-882.0	Seal Kit: Ultra Clean
8.701-883.0	Complete Swivel Kit: Ultra Clean
8.750-604.0	Complete Swivel Kit: New Style
8.707-653.0	2.5 x 25° 1/4" Nozzle Fits All

## SURFACE CLEANER NOZZLE RECOMMENDATION

Determine the correct nozzle size for the pressure washer being used with the surface cleaner. Never use a smaller size nozzle as this will prematurely wear out the unloader valve on the pressure washer. The Legacy Undercarriage Cleaner and A+ Surface Cleaners come supplied with nozzles; for other surface cleaners, nozzles must be purchased separately. Threaded nozzles are listed on pages page 167-171 of the catalog, to determine your pressure washer nozzle size refer to chart on page 164. Contact us for additional sizes for surface cleaner spray bars which use four nozzles.

PRESSURE WASHER NOZZLE SIZE	QUANTITY NEEDED	1/8" OR 1/4" MPT
#3.5 and #4.0	2 each	#2.0
#4.5 and #5.0	2 each	#2.5
#5.5 and #6.0	2 each	#3.0
#6.5 and #7.0	2 each	#3.5
#7.5 and #8.0	2 each	#4.0

**UNDERCARRIAGE CLEANER**

No more crawling under a vehicle. Effortlessly wash away damaging debris from the bottom of your vehicle with the easy to handle and maneuver Legacy Undercarriage Cleaner. Simply connect to your hot or cold water pressure washer to remove road grime, fuel and oil contaminants, snow sludge, and ice. The stainless-steel rotating nozzle assembly requires a 5.5" under vehicle clearance.

- PSI: 4000
- GPM: 10.5
- Temperature: 250°F
- Four Nozzles:
  - (2) 0° #2.0
  - (2) 25° #2.0



PART NO.	DESCRIPTION
8.749-303.0	 Undercarriage Cleaner

**UNDERCARRIAGE CLEANER & ROOF SURFACE CLEANER**

**UNDERCARRIAGE CLEANER**

- PSI: 4000 PSI
- GPM: 10.5
- Temperature: 210°F
- 1/4 " 2.5 Nozzle
- Universal Inlet Fitting Kit to Accommodate All Common Configurations
- 17cm Plate Height
- 26 lbs.



**ROOF SURFACE CLEANER**

- PSI: 4000 PSI
- GPM: 10.5
- Temperature: 210°F
- 1/4 " 2.5 Nozzle
- 3/8" QC Socket
- 22 lbs.



PART NO.	DESCRIPTION
9.112-965.0	Undercarriage Cleaner, 20" Stainless-steel
9.112-966.0	Roof Surface Cleaner, 20" ABS
<b>REPAIR KITS</b>	
9.113-083.0	Replacement Gun (for Undercarriage Cleaner)
9.113-074.0	Swivel (for Undercarriage Cleaner)
9.113-076.0	Swivel (for Roof Surface Cleaner)
9.113-075.0	Spraybar (for Undercarriage Cleaner)
9.113-077.0	Spraybar (for Roof Surface Cleaner)
9.113-096.0	Caster Wheels 1.5" (for Undercarriage Cleaner)
9.113-095.0	Caster Wheels 3" (for Undercarriage Cleaner)
9.113-094.0	Caster Wheels 5" (for Roof Surface Cleaner)

**LOWER PRICE WATER BROOM 16"**

- PSI: 4000
- GPM: 8.0
- Temperature: 250°F
- Includes 1/4" Plug and 4 Nozzles (pre-installed)- PN# 9.106-054.0
- Requires Wand (sold separately)



PART NO.	DESCRIPTION
8.710-082.0	Water Broom 16"



## UNDERBODY WAND ASSEMBLY - SELF SERVE



Ideal for rinsing the undercarriage of cars and trucks. Connect directly to a pressure washer. The lightweight underbody wand assembly rolls easily, giving the operator a longer reach.

- PSI: 3000
- Temperature: 300°F
- Inlet/Outlet: 1/4" M x F
- Non-weeping
- Stainless Steel
- ST-601 Inline Trigger Gun & Three 25°, #2, 1/8" MEG Nozzles (included)



PART NO.	DESCRIPTION
8.755-257.0	Self Serve Underbody Wand Assembly

## SURFACE CLEANERS / DUCT CLEANER - MOSMATIC



### DUCT CLEANER

Designed as an accessory for use with high-pressure pumps or pressure washers. Cleans ducts, chutes, vents, restaurant exhausts, tanks, etc.

Self-rotating and feeding stainless-steel triple bearing system for constant easy turning. Nozzle holders are 1/8" NPTF. Nozzles are sold separately.



- PSI: 4000
- Temperature: 250°F
- Inlet Ports 3/8" NPTF
- Weight: 2 lbs.

### 12" SURFACE CLEANER

Designed for effortless cleaning of small areas, including walls and angled surfaces. High RPM swivel with integrated toggle joint and adjustable tension system.

- PSI: 4000
- Temperature: 250°F
- Weight: 9 lbs.
- 12" Stainless-Steel
- Includes All Items Pictured



PART NO.	DESCRIPTION	PSI
8.712-280.0	Duct Cleaner TXR-2s, Adjustable	4000
8.712-279.0	Duct Cleaner TXR-2s, Fixed	4000
8.749-911.0	Surface Cleaner, 12"	4000
8.712-285.0	Toggle Joint KGK	4000

## LOWER PRICE SANDBLAST KIT - TUNGSTEN CARBIDE NOZZLE HEAD - INDUSTRIAL

A Venturi orifice creates a uniform blast pattern, doubles sand velocity and produces up to 45% more work with 20% less sand.



- PSI: 1500 - 5500
- GPM: 3.0 - 10.0
- Temperature: 200°F
- Weight: 10 lbs.
- Nozzle Tip (sold separately)

PART NO.	DESCRIPTION
8.701-485.0	Industrial Sand Blast Kit
8.725-620.0	Replacement Carbide Nozzle

## SANDBLAST HEAD - PROFESSIONAL



- PSI: 3500
- GPM: 10.0
- Temperature: 200°F
- Long-Wearing Carbide Sand Nozzle
- 1/4" FPT Water Inlet
- Sand Probe Weight: 6oz..
- Head Weight: 13oz..
- Length: 16"

PART NO.	DESCRIPTION	NOZZLE SIZE
8.711-242.0	Sandblast Head	3.5
8.711-243.0	Sandblast Head	4.0
8.711-244.0	Sandblast Head	4.5
8.904-403.0	Sandblast Head	5.0
8.711-245.0	Sandblast Head	5.5
8.904-404.0	Sandblast Head	6.0
8.711-247.0	Sand Probe	
8.901-264.0	1/2" ID Polybraided Tubing, 25'	

## SANDBLAST NOZZLE TIPS



- Replacement Tips for Sandblaster Kit
- Use 1/4" Meg 5" Spray Tip

PART NO.	DESCRIPTION
8.707-668.0	4.0 x 5° Tip
8.707-685.0	5.0 x 5° Tip
8.707-696.0	5.5 x 5° Tip
8.707-701.0	6.0 x 5° Tip
8.707-709.0	6.5 x 5° Tip



**SANDBLASTERS - INDUSTRIAL**

For the extra-tough cleaning jobs, wet-sandblasting is the dust-free solution. The sandblasters attach to a hot or cold water pressure washer and, using a venturi, mixes sand or other abrasive media with the high-pressure spray to create enough cleaning power to strip paint off concrete and barnacles from a ship's hull. The sandblasting nozzle is made of tungsten carbide for long life. There are two models—a top-of-the-line steel pot with tight-fitting lid or with a probe only.

- Quick-connect coupler for ease in attaching sand probe or pot
- Valve for metering the flow of the media
- Tubed, pneumatic tires for easy maneuvering
- Rating: Super-duty
- Recommended Usage: Heavy
- Attach to any hot or cold water pressure washer with minimum volume of 4 GPM



**8.904-472.0**



**8.904-470.0**

PART NO.	DESCRIPTION
8.904-470.0	Sandblaster with Pot (Carbide)
8.904-472.0	Sandblaster with Probe (Carbide)

NOTE: Excluded from any dealer freight programs

**SANDBLAST HOSE**

Heavy-duty spiralite hose available preassembled or by the foot.



- 3/4" spiralite sand hose with air hose locking couplers
- Temperature: -30°F to 130°F

PART NO.	DESCRIPTION	SIZE
8.711-809.0	Sand, Spiralite /ft	3/4"
8.711-839.0	Assy, Sand, Spiralite	3/4" x 25'
8.711-840.0	Assy, Sand, Spiralite	3/4" x 40'
8.711-811.0	Sand, Spiralite /ft	1"

**SAND NOZZLE**

Tungsten Carbide provides maximum durability for sandblasting application.



- Carbide insert
- Light weight
- Easily changed-30°F to 130°F

PART NO.	DESCRIPTION
8.712-416.0	Carbide Sand Nozzle

**STEAM LANCE**

Completely insulated for maximum protection.

- Lance with steam nozzle shown
- Vented grip full length of lance



PART NO.	DESCRIPTION
8.904-444.0	48" with Steam Nozzle
8.904-441.0	48" without Steam Nozzle



## FOOT-CONTROLLED PRESSURE VALVE



Operators of sewer and tube cleaning equipment need both hands free to feed or retract the hose in the sewer line. Foot-operated valve allows hands-free control.



8.710-134.0

- PSI: Up to 5000
- GPM: 12.0
- Inlet 3/8", Outlet 1/4"



8.709-972.0

- Brass Body
- Stainless-steel Valve

PART NO.	DESCRIPTION	PSI
8.710-134.0	Sewer Cleaner Foot Valve	3000
8.709-972.0	Foot Valve with ST-2305	5000
8.701-657.0	Repair Kit - Foot Valve	
8.701-673.0	Repair Kit ST-2305	
8.711-526.0	Kit, 25' Hose, #4.5 Nozzle, Foot Valve	

\*Heavy gauge steel construction for durability and stability

## SLUDGE SUCKER - ST-36 PIT BOSS



Sludge Sucker uses a high-pressure water stream from 1000-3000 PSI to suck the sludge off the bottom of pits or tanks and eject it through a 1-1/2" diameter 15' long hose to a disposal tank.

The base unit attaches to the end of a pressure washer lance with a quick coupler for extension to the bottom of the pit. Uses a 0° tip for suction / power ejection.



- Easy to change for different plumbing system flows and pressures



- Uses Standard 1/4" MPT Nozzle

PART NO.	DESCRIPTION
8.711-112.0	ST-35 Pit Boss, 5.5 Nozzle, 15' Hose
8.711-110.0	Base Unit Only

\*without Hose, Nozzle or Quick Coupler (3/8" Inlet Port)

## DRUM PUMPS - RED HEAD

Siphon liquids from higher to lower levels. Simply pump the bellows a few times to prime and start flow. Loosen air lock to stop.



- Drum Pump fits 15-, 30- and 55- Gallon Drums
- Fit 2" Bung Opening
- Excellent for Alkaline and Acidic Chemicals, Diesel Fuel and Oils
- Not for Use with Solvents

PART NO.	DESCRIPTION
8.704-698.0	Red Hex Head, Heavy-duty
8.704-696.0	Red Head, Standard-duty
8.704-694.0	Pail Pump, 5 Gallon

## DRUM / TANK PUMP - CRANK STYLE

Chemical-resistant, lightweight pump, ideal for dispensing chemicals, pesticides and oils. Polypropylene for most alkalis, dilute acids, pesticides and most oils and solvents. Ryton for extremely aggressive acids, aromatic and aliphatic hydrocarbons.



- 11 oz. Per Revolution
- 6.0 GPM at 70 RPM
- Viton Seals
- Polypropylene Gasket
- Outlet 3/4" Barb Two-piece
- 2" Bung Adapter
- 47" Suction Tube
- Weight: 2.6 lbs.

PART NO.	DESCRIPTION
8.704-700.0	Polypropylene Pump, Standard
8.704-701.0	Ryton Pump, Deluxe
8.700-526.0	Replacement Handles

## DRUM PUMPS - TOOLS / ACCESSORIES

The indispensable tools.



8.712-534.0



8.704-689.0



8.704-692.0



8.704-691.0

PART NO.	DESCRIPTION
8.712-534.0	Drum Plug Wrench
8.704-689.0	Lid-Off
8.704-691.0	Funnel, 7" x 10"
8.704-692.0	3/4" Faucet
8.704-693.0	2" Faucet

**BRUSHES**

Rotating brush, natural bristle (soft) used for painted surfaces. Nylon bristle (stiff) used for removing scum and grime on fiberglass boats, etc.



- Internal Nozzle: Size 20
- GPM: 8.0

PART NO.	DESCRIPTION
<b>BRUSH UNIT COMPLETE</b>	
8.709-312.0	Natural
8.709-314.0	Nylon
<b>REPLACEMENT BRUSHES</b>	
8.709-313.0	Natural
8.709-316.0	Nylon



**Truck/Tractor Wash Brush**

- Flag-Tipped
- Soft Bristle
- Acme Thread for Super Handles or Broom Handles

8.709-298.0

PART NO.	DESCRIPTION
8.709-298.0 <b>S</b>	2-1/2" Bristle with Bumper x 10"
8.709-303.0	2-1/2" Bristle x 18"
8.709-304.0	2-1/2" Bristle x 24"
8.709-305.0	60" Flow Thru Lance*

\*With Acme Thread and Garden Hose Attachment



**Deck Scrub Brush - Over / Under**

- Not a Flow Thru
- Excellent Chemical Resistance
- Use with Threaded Handle
- Trimmed for Cleaning Hard-to-reach Areas
- Stiff Polypropylene Bristle for Aggressive Cleaning
- Unique Heavy-duty Scrub Brush with Multi-level Angle
- 10" Molded Polypropylene Foam Block does not Warp or Absorb Water

PART NO.	DESCRIPTION
8.709-302.0	Deck Scrub Brush

**HANDLES - FIBERGLASS "SUPER HANDLES"**



- Tough, Durable, Lightweight
- No Cracking, Splintering
- No Kinks, Dents
- Safer Around Electrical Hazards
- Super Heavy-duty Aluminum Alloy Threads
- Easy-twist Cam Lock Extension
- Standard 3/4" Acme Thread Fits: Brooms, Brushes, Utility Tools
- Optional Reduction Adapter for 3/4" to Acme Standard

PART NO.	DESCRIPTION
<b>SUPER HANDLES</b>	
8.709-306.0	48" Length (4')
8.709-307.0	60" Length (5')
8.709-308.0 <b>S</b>	72" Length (6')
<b>SUPER-EXTENSION HANDLES</b>	
8.709-309.0	4' to 8' Extension
8.709-310.0	6' to 12' Extension
8.709-311.0	8' to 16' Extension
8.700-308.0	Threaded Adapter

**FOAMERS - FOAM CANNON**

The ideal Foam Generator Application Accessory meters the foaming chemical for customized foam type and applies the foam to match the application.



- PSI Max: 3000
- GPM Max: 4.8
- Temperature: 140°F
- Brass Meter Valve
- High-impact, Glass Filled Body
- Stainless-steel Foam Turbulator
- 1/4" FPT Lance Connect
- Stainless-steel 1.5mm Orifice (#5.5 nozzle equivalent)

PART NO.	DESCRIPTION
8.710-125.0 <b>S</b>	Foam Cannon / Injector
8.710-126.0 <b>S</b>	Foam Cannon / Injector / Bottle
8.704-222.0	Replacement Turbulator Screen
8.749-826.0	Replacement Bottle



## FOAMERS - PF22 MTM HYDRO FOAM CANNON



- PSI Max: 5000
- GPM Max: 5.3
- Temperature: 140°F
- Inlet: 1/4" Q.C. Plug
- 1/4" M22 Adapter (Included)
- 1/4" x 9" Tube for Drawing Chemical
- 3.5 Orifice (1.25 mm) (installed in the foamer body)
- 3.0 orifice (1.1 mm) (included)

PART NO.	DESCRIPTION
8.758-981.0	PF22.2 MTM Hydro Foam Cannon
9.112-494.0	PF22 3pk Replacement Bottle W/
9.112-945.0	PF22 5pk Replacement Bottle W/

## FOAMERS - SUTTNER ST-75/76 KITS



Clean with foam and save time as well as use half the chemical. Many sizes and variations available. Ask us for additional size options. Foam injector conveniently attaches after the pump and unloader on your pressure washer.



- ST-75 FOAM NOZZLE**
- PSI: 4000
  - Inlet 1/4"
  - Weight: .31 lbs.



- ST-76 FOAM NOZZLE**
- PSI: 3625
  - Inlet: 1/2"
  - Weight: 1.15 lbs.



- ST-160 INJECTOR**
- PSI: 5000
  - Stainless-steel Housing
  - Single Chemical
  - Inlet/Outlet: 3/8" F x M
  - Weight: .71 lbs.

PART NO.	DESCRIPTION	ORIFICE
9.113-063.0	Kit 1: ST-75 Nozzle & ST160 Injector	2.0-3.5
9.113-064.0	Kit 2: ST-75 Nozzle & ST160 Injector	4.0-5.5
9.113-065.0	Kit 3: ST-75 Nozzle & ST160 Injector	6.5-7.0
9.113-066.0	Kit 4: ST-76 Nozzle & ST160 Injector	7.5-8.5
9.113-067.0	Kit 5: ST-76 Nozzle & ST160 Injector	9.0-12.0

## FOAMERS - LEGACY COMPACT



Generates a high-density clinging foam for extended dwell-time to increase chemical action.



- PSI: 2500
- GPM: 1.0 to 5.0
- Temperature: 195°F
- Stainless-steel, Aluminum and Brass
- 5" Long, 1" Diameter
- 4 and 6.5 Nozzle Included

PART NO.	DESCRIPTION
8.903-998.0	1/8" F Inlet
8.903-999.0	1/4" F Inlet

Note: Most cleaning chemicals perform best when applied at 120° - 150°F and can be applied as a foam by adding a foaming agent. See your chemical supplier to obtain the correct product.

## FOAMERS - LAFFERTY AIRLESS 10/20 SS



- Machined Stainless-steel Construction
- Stainless-steel Chemical Check Valve & Quick Disconnects
- Temperature: 180°F Max
- Chemical Tube with Strainer: 10SS: 6" & 20SS - 10"
- Color-coded Metering Tips for up to 21 Dilution Ratios
- 0° nozzle for Increased Foam-throw Distance

PART NO.	DESCRIPTION	FLOW RATE @ 2000 PSI
8.749-908.0	10SS Combo	4.0 GPM
8.749-909.0	20SS Hose End	6.0 GPM

## FOAMERS - FOAM JET KIT



Long-distance foam applicator. Shoots over 20 feet of dense foam. Suction at 30 feet of height. Variable spray pattern.



- PSI: 5000
- GPM: 5.6
- Temperature: 140°F
- 1/4" Inlet
- 33' Tube

PART NO.	DESCRIPTION
8.750-296.0*	Foam Jet Kit, 5000 PSI, 5.6 GPM
8.750-429.0	Foam Repair Kit, O-Rings/ Stainless-Steel Filter
8.750-430.0	Foam Jet Repair Kit, Hose, Valve & Filter

\*Includes tubing and fittings as shown

**FOAMERS - ADJUSTABLE WITH TANK**

Control the foam spray angle with the variable fan nozzle.



- PSI: 2600
- GPM: 5.3
- Temperature: 140°F
- Horizontal Variable Fan Nozzle
- Foam Control Adjustment Knob

PART NO.	DESCRIPTION
8.710-124.0	 Adjustable Foamer with Tank

**TAPE - TEFLON® THREAD SEALING**



- Big 1/2" x 520" Roll
- Mil - Spec #T27730

PART NO.	DESCRIPTION
8.704-705.0	 Thread Sealing Tape

**SPRAYERS - B&G POLY-MOLDED**

3-gallon poly-molded sprayer with maximum chemical resistance.



- Heavy-Duty Design, Economical Price
- Blue Poly-Molded Tank
- Funnel Top Design for Ease-of-filling
- Braided, Reinforced Hose
- Durable Plastic Valve and Extension
- Pin-to-cone Spray Tip Fully Repairable
- Optional Flat-Fan Spray Tips
- Buna Gaskets and Seals

PART NO.	DESCRIPTION
8.697-172.0	Poly-molded Sprayer

**DISINFECTANT - VITAL OXIDE**

Vital Oxide is an EPA registered disinfectant and sanitizer with the following key attributes: Disinfection, Sanitizing, Odor Elimination, Eliminates SARS-CoV-2 (COVID-19), Carpet Sanitization, Allergen Removal, Kills Mold and Mildew, Parvo, Distemper, Tuberculous. Sanitizer dilution is NSF approved as a no rinse sanitizer for non-porous food contact surfaces. (US Only).



- pH: 8.0 - 9.0
- Color: Clear
- Scent: None
- Dilution: Disinfection: RTU  
Carpet Sanitizing: 1 : 5  
Sanitizing: 1 : 9
- Foam (1-5): 2
- Phosphate Free

PART NO.	DESCRIPTION
8.639-560.0	Vital Oxide, 6 x 32 oz
8.639-558.0	Vital Oxide, 4 x 1 gal
8.644-292.0	Vital Oxide, 5 gal
8.642-823.0	Vital Oxide, 15 gal
8.698-112.0	Vital Oxide, 55 gal

**SPRAYERS - CHAPIN AIR-POWERED**



- Pump-up Style
- Heavy-duty Plastic Sprayers for Chemical Applications
- Adjustable Nozzle - Mist to Solid Stream
- 2-Gallon Sprayer has 2' Hose and Hand Trigger
- Excellent Chemical Resistance
- Locking Hand Pump Handle Serves as Carrying Handle

PART NO.	DESCRIPTION
8.704-703.0	Thumb Button 3 Pint
8.704-702.0	2-Gallon Sprayer

**RAIN SUIT, 2 PIECE**



- Heavy-duty, 2-ply Laminated Vinyl (25 mil)
- Jacket and Pants
- Bright Safety Yellow
- Vented for Air Flow

PART NO.	DESCRIPTION
8.704-666.0	Large
8.704-667.0	Extra Large



## THREAD LOCK PRODUCTS



- Direct Replacement for Loctite® & Fel-Pro™ Products
- Excellent Lubricant
- Prevents Corrosion and Fretting
- NDTM Anaerobic Adhesives: Liquid Materials that Cure to a Solid, Chemical-resistant Plastic State when Air is Not Present

PART NO.	DESCRIPTION	LOCTITE® EQUIV	BOTTLE SIZE
8.704-644.0	Nut Grade™	242	10 ml
8.704-645.0	Nut Grade™	242	50 ml
8.704-646.0	Nut Grade™	242	250 ml
8.704-648.0	Stud Grade™	271	10 ml
8.704-649.0	Stud Grade™	271	50 ml
8.704-650.0	Penetrating Adhesive (Sealant)	290	10 ml

Nut Grade™ & Stud Grade™ are trademarks of the Oakland Corp. Loctite® is a registered trademark for the Loctite® Corp.

## GLOVES - INDUSTRIAL DUTY

Industrial-grade gloves for most industry-needs – chemical, heat, abrasion protection.



### BLACK PVC GLOVE

- 14" PVC Glove
- Lined with Cotton
- Good for Chemical Handling
- Resists alkalines, Acids
- Great as Sandblasting Gloves

PART NO.	DESCRIPTION
8.704-669.0	Black PVC Glove

## HAND CLEANER - VICTOR WATERLESS COMMAND-O WITH PUMICE

A unique blend of natural citrus extract (limonene), aloe vera, glycerine, and lanolin, plus medication creates Command-O. Command-O combats the toughest cleaning task including grease, ink, tar, paint, dirt and stains.



- Conditioning agents protect hands and prevent drying, chapping and cracking
- Perfect for those whose hands are exposed to harsh, dirty working conditions
- No petroleum-based solvents

PART NO.	DESCRIPTION
8.704-635.0	Command-O Hand Cleaner with Pumice, 1 gal



**HOSE REELS - LEGACY STACKABLE**



Hose reels built specifically for contractors who require flexibility on a job site. Stackable reels are supported on both sides of the central hub to accommodate more aggressive applications, such as trailer-mounted.



**200' Mild Steel Stackable Hose Reel**

**100' Mild Steel Stackable Hose Reel**

- Integrated frame adds protection and stacking ability
- Stack up to 3 high
- Heavy-duty powder-coated steel or stainless steel
- Reel and swivel rated up to 6000 PSI and 350°F
- Modular design is able to configure for various needs
- Reversible hand-crank and swivel

**Options**



**Reel Cart System**



**Hose Reel Riser**



**Hose Guide**

PART NO.	DESCRIPTION
9.801-767.0	Stackable Hose Reel, Mild Steel, 100'
9.801-768.0	Stackable Hose Reel, Mild Steel, 200'
9.801-770.0	Stackable Hose Reel, Stainless-steel, 200'

OPTIONS	
8.923-415.0	Hose Guide, 100' Reel
8.923-427.0	Hose Guide, 200' Reel
8.923-416.0	Hose Reel Riser
8.923-918.0	Reel Cart System

NOTE: Hose not included

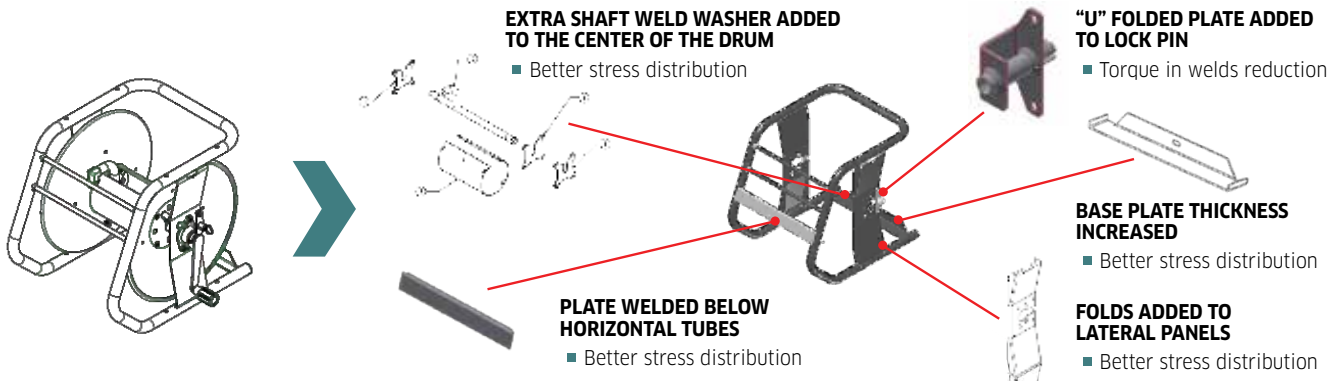



## HOSE REELS - LEGACY PIVOT & FIXED BASE



Legacy hose reels were designed for ease of use and durability in commercial pressure washer applications. Offering 100' and 200' reels in both a fixed base and 360 degree rotating base. The oversized reel holds the advertised length plus leaves additional space reducing the difficulty of reeling hose. The unique extended swivel improves the hose connection and reduces hose wear and stress.



Fixed Base Reel

Trailer Mount Reel

360° Pivot Reel

### Bracket Sockets



Universal Mount

Skid Mount

Wall Mount

Base Mount

### Non-Pivot Reel Brackets



Universal

90°

45°

Vertical

- PSI: 5000
- Temperature: 325°F
- 100' - 200' Fixed Base
- 100' - 200', 360° Rotating Base
- High-Pressure, Double-Seal Swivels
- Reels equipped for 3/8" hose. Easily convertible to 1/2" hose with the change to a 1/2" swivel
- 2-Year Warranty

PART NO.	DESCRIPTION
8.750-485.0	Pivot Reel, 100' x 3/8"
8.750-482.0	Pivot Reel, 200' x 3/8"
8.750-476.0	Fixed Based, 100' x 3/8"
8.750-479.0	Fixed Based, 200' x 3/8"
8.920-142.0	Hose Reel, Trailer Mount, 100'
8.920-143.0	Hose Reel, Trailer Mount, 200'
8.919-430.0	Universal Mount
8.919-794.0	Skid Mount
8.919-437.0	Wall Mount
8.919-434.0	Base Mount
8.919-072.0	Bracket, Universal
8.919-445.0	Bracket, 90°
8.919-441.0	Bracket, 45°
8.919-448.0	Bracket, Vertical
9.121-043.0	Handle, Replacement

NOTE: Hose not included

## HOSE REELS - LEGACY SWIVELS



- PSI: 5000
- Innovative Design
- Stainless-Steel Rotor
- Unique Dual Seal for Extra Long Life
- 2-Year Warranty
- O-Rings; BUNA-N



- PSI: 5000
- Limits Bend and Hose Stress
- Stainless-Steel Rotor
- Unique Dual Seal for Extra Long Life
- 2-Year Warranty
- O-Rings; BUNA-N

PART NO.	INLET X OUTLET
<b>SWIVEL</b>	
9.118-021.0	1/2" M x 3/8" F
8.776-003.0	3/8" F x 1/2" F
9.118-023.0	3/8" M x 3/8" F
9.118-024.0	3/8" F x 3/8" F
9.118-025.0	1/2" M x 1/2" F
9.118-026.0	1/2" F x 1/2" F
9.118-027.0	3/8" M x 1/2" F
9.118-028.0	1/2" F x 3/8" F
<b>UNIVERSAL REPAIR KIT</b>	
8.776-001.0	

PART NO.	INLET X OUTLET
<b>EXTENDED SWIVELS</b>	
9.118-020.0	1/2" M x 3/8" F
9.118-029.0	1/2" F x 3/8" F
9.118-030.0	3/8" M x 3/8" F
9.118-031.0	3/8" F x 3/8" F
9.118-034.0	1/2" F x 1/2" F
9.118-035.0	1/2" M x 1/2" F
9.118-032.0	3/8" F x 1/2" F
9.118-033.0	3/8" M x 1/2" F
<b>UNIVERSAL REPAIR KIT</b>	
8.776-001.0	

**HOSE REELS - AP**

AP hose reels have been designed to perfectly balance ruggedness and durability with affordability.



- Working PSI: 4000
- Rated Temperature: 225°F
- 3/8" or 1/2" Inlet / Outlet
- Flared Flanges for Maximum Capacity
- Solid Center Core for Maximum Strength
- Rolled, Beaded-Edge Flanges for Maximum Safety
- Easy Mounting Options for Maximum Versatility
- "Posi-Pin" Lock Prevents Unwanted Dereeling
- Heavy-Duty Powder-Coated Steel
- Easy Access External Swivel

PART NO.	HOSE DIAMETER	CAPACITY (FT)	CORE WIDTH	FLANGE WIDTH	FLANGE DIAMETER	OVERALL HEIGHT
8.711-192.0	3/8"	50	4.3	7.9	10.5	13"
9.804-067.0	<b>S</b> 3/8"	100	8.7	12.2	10.5	13"
8.711-199.0	3/8"	150	6.3	10.2	13.0	16.7"
8.711-201.0	1/2"	100	6.3	10.2	13.0	16.7"
8.712-460.0	Replacement Swivel for Part No. 8.711-192.0 and 9.804-067.0					
8.712-469.0	Replacement Swivel for Part No. 8.711-199.0					
8.754-280.0	Replacement Swivel for Part No. 8.711-201.0					
8.700-188.0	Replacement Handle					

**SWIVEL REPAIR KITS**

**8.900-855.0**

Note: Hose is not included. See page 143 for connector hose.



- Working PSI: 4000
- Rated Temperature: 225°F
- Super-Reinforced Core - Won't Collapse!
- Adjustable Brake for Controlled Reel Tension
- Convenient External Swivel
- Manual Rewind Handle Included
- Solid Core Bolts on to Flanges for Extra Strength
- Snap-Lock to Prevent Accidental Dereeling
- Bearings Have Oil Cap for Easy Field Maintenance

PART NO.	HOSE DIAMETER	CAPACITY (FT)	REEL SIZE WIDTH	REEL SIZE DIAMETER
8.711-179.0	3/8"	90	6"	14"
8.711-180.0	3/8"	140	10"	14"
8.711-181.0	3/8"	200	14"	14"
8.711-186.0	1/2"	115	10"	14"
8.711-187.0	1/2"	150	14"	14"
8.711-182.0	3/8"	150	6"	18"
8.711-183.0	3/8"	300	10"	18"
8.711-184.0	3/8"	350	14"	18"
8.711-189.0	1/2"	200	10"	18"
8.711-190.0	1/2"	270	14"	18"
8.715-921.0	Replacement Brake for Part No. 8.711-182.0 and 8.711-183.0			

NOTE: Hose is not included. Interchangeable parts available. Call for pricing. See page 143 for connector hose.

PART NO.	HOSE DIAMETER	DESCRIPTION
8.700-287.0	3/8"	Swivel Repair Kit
8.700-285.0	1/2"	Swivel Repair Kit
8.900-855.0*		Swivel Repair Kit

\*For Round Swivels. Replacement Swivels, See page 148-149.



## HOSE REELS - COXREELS

Coxreels offer high performance in a very compact and lightweight hand crank or spring-driven hose reel. Perfect for mobile application and permanent floor and wall mount.



**8.711-858.0**

- Rated Up to 4000 PSI
- Temperature: -20°F to 225°F
- Adjustable Drag Brake
- 90° Brass Swivel



**8.723-649.0**

- Spring Driven Hose Reel
- Lightweight, Compact Design
- Adjustable Drag Break
- Sturdy U-Shaped Frame
- PSI: Up To 4000
- Rolled edges and ribbed discs provide strength and safety
- Pro-Grade Heavy-Duty Steel
- 2-Year Mfg Limited Warranty



**8.711-858.0**  
(Hose and Ball Stop Not Included)

PART NO.	DESCRIPTION	PSI
8.711-858.0	200' x 1/2" (300' x 3/8" with Adapter)	3000
8.711-860.0	100' x 3/8" - Challenger - Hand Crank Reel	4000
9.802-265.0	150' x 3/8" - Challenger - Hand Crank Reel	4000
8.723-649.0	50' x 3/8" - HPL Series - Spring Driven Reel	4000
8.723-718.0	100' x 3/8" - HPL Series - Spring Driven Reel	3000
8.711-591.0	Handle Replacement	
8.711-588.0	Locking Pin Assembly	
8.705-132.0	1/2" to 3/8" Adapter for 8.711-858.0	
8.750-020.0	Ball Stop for 8.723-649.0	
8.711-585.0	Replacement Swivel, 3/8"	
8.711-584.0	Replacement Swivel, 1/2"	
8.711-587.0	Swivel Repair Kit, 3/8"	
8.711-590.0	Swivel Repair Kit, 1/2"	

**NEW OFFERING HOSE REELS - GENERAL PUMP A-FRAME HOSE REELS**



- Working PSI: 4000
- Rated Temperature: 225°F
- 3/8" NPT-F Inlet / Outlet
- Heavy Duty Powder Coated Steel
- Jumper/Pigtail Hose Not Included



9.112-948.0



9.112-952.0  
(reel not included)



9.112-955.0  
(reel not included)



9.112-951.0  
(reels not included)

PART NO.	DESCRIPTION	PSI
9.112-948.0	DHRA50150, 150' x 3/8" Charcoal Gray Steel <b>A-frame Hose Reel</b> with Stainless-steel Swivel	5000
9.112-949.0	DHRA50300, 300' x 3/8" Charcoal Gray Steel <b>A-frame Hose Reel</b> with Stainless-steel Swivel	5000
9.112-950.0	DHRA50450, 450' x 3/8" Charcoal Gray Steel <b>A-frame Hose Reel</b> with Stainless-steel Swivel	5000
ACCESSORIES		
9.112-951.0	Hose Reel Stacking Kit, DHRA50150 A-frame c/w 150'/300' Cross Bracket	
9.112-952.0	Hose Guide Kit, DHRA50150 A-frame Hose Reel (reel not included)	
9.112-953.0	Hose Guide Kit, DHRA50300 A-frame Hose Reel (reel not included)	
9.112-954.0	Hose Guide Kit, DHRA50450 A-frame Hose Reel (reel not included)	
9.112-955.0	Hose Reel Cart, A-frame (150', 300', 450') Complete with DP80052 10" Solid PU Wheels (cart only)	

**NEW OFFERING HOSE REELS - GENERAL PUMP SWIVELS**



9.112-946.0

PART NO.	DESCRIPTION	PSI	DESCRIPTION	MATERIAL
9.112-944.0	Swivel (D30001/02 / DHRWM50200)	4000	3/8"	Brass
9.112-945.0	Swivel, Hex Outlet with Arm (DHR50100, DHR50150, 2100357)	5000	3/8" NPT-F	Brass
9.112-946.0	Swivel, A-frame Hose Reels 440A, Bearing with Zerk Fitting, Electro-polished Surface, Viton Seals	5000	1/2" NPT	Stainless-steel
9.112-947.0	Swivel, A-frame Hose Reels 440A, Bearing with Zerk Fitting, Electro-polished Surface, Viton Seals	5000	3/8" NPT-F	Stainless-steel
9.114-676.0	Repair Kit for DHRA Hose Reel Swivel			

## LEGACY "BEST" SPRAY GUN

Ergonomically designed to be the most comfortable gun on the market.

Legacy



- PSI: 5000
- GPM: 12
- Temperature: 300°F
- 3/8" FPT Inlet x 1/4" FPT Outlet
- Weight: 21 oz.

PART NO.	DESCRIPTION
8.751-213.0	S "Best" Spray Gun
8.701-673.0	Unitized Valve Kit

## LEGACY "INDUSTRIAL" SPRAY GUN

Featuring a comfortable grip to reduce user fatigue.

Legacy



- PSI: 5000
- GPM: 10.4
- Temperature: 300°F
- 3/8" FPT Inlet x 1/4" FPT Outlet
- Weight: 19.84 oz.

PART NO.	DESCRIPTION
8.751-214.0	S "Industrial" Spray Gun
8.751-119.0	S Valve Kit

## MV925 TRIGGER GUN

Economical easy pull trigger gun.



- PSI: 4500
- GPM: 8
- Temperature: 320°F
- 3/8" FPT Inlet x 1/4" FPT Outlet
- Weight: 16.08 oz.

PART NO.	DESCRIPTION
8.754-907.0	MV925

## M407 TRIGGER GUN



- PSI: 4000
- GPM: 7
- Temperature: 250°F
- 3/8" FPT Inlet x 1/4" FPT Outlet
- Weight: 13.4 oz.

PART NO.	DESCRIPTION
8.750-247.0	M407 Trigger Gun
8.750-456.0	M407 Gun Repair Kit

## ECONOMY TRIGGER GUN

TOP  
SELLER



- PSI: 5000
- GPM: 12
- 3/8" Female Inlet x 1/4" Outlet
- Weight: 23 oz.
- Private Label this Gun  
*Ask your sales rep*

PART NO.	DESCRIPTION
9.113-082.0	Economy Trigger Gun
9.113-100.0	Unitized Valve Kit

## GIANT TRIGGER GUNS

The original "heavy-weight".

GIANT



21290C

- PSI: 5000
- GPM: 10
- Temperature: 300°F
- 3/8" FPT Inlet x 1/4" FPT Outlet
- Weight: 29.28 oz.

PART NO.	DESCRIPTION
8.710-394.0	S 21290C - Brass Outlet
8.710-392.0	S 21250B - Stainless-Steel Outlet
8.722-172.0	Repair Kit for Giant 212990C and 21250B

## CERAMIC UNITIZED BALL VALVE

SUTTNER



- Ceramic Ball
- Highly Resistant Against Nearly All Soaps and Acids
- Fits in ST-2300, 2305, 2605, 2700 Spray Guns as a Repair Kit

PART NO.	DESCRIPTION
8.749-907.0	Ceramic Unitized Ball Valve

## ST-2720 SUTTNER TRIGGER GUN

SUTTNER

Designed for operators and applications with longer periods of cleaning time. Featuring the Relax-Action™ German engineered technology reduces trigger pulling force by 40% and holding force up to 90% compared to usual competitors spray gun.



- PSI: 1800
- GPM: 21.0
- Temperature: 300°F
- 3/8" Female NPT Inlet x 1/4" Female NPT Outlet
- Weight: 20 oz.

PART NO.	DESCRIPTION
8.723-667.0	ST-2720 Gun



**ST-2305 SUTTNER TRIGGER GUN** 

Easy pull trigger.



- PSI: 5000
- GPM: 12
- Temperature: 300°F
- 3/8" FPT Inlet x 1/4" FPT Outlet
- Weight: 16.22 oz.

PART NO.	DESCRIPTION
8.758-457.0	ST-2305 Spray Gun, Safety Orange

**ST-810 SUTTNER TRIGGER GUN** 

Excellent for truck and fleet washing applications.



- PSI: 2000
- GPM: 8
- Temperature: 320°F
- 3/8" FPT Inlet x 1/4" FPT Outlet
- Weight: 19.5 oz.

PART NO.	DESCRIPTION
8.710-372.0	ST-810 Gun

**ST-2605 SUTTNER TRIGGER GUN** 

Relax action design.



- PSI: 5000
- GPM: 12
- Temperature: 300°F
- 3/8" FPT Inlet x 1/4" FPT Outlet
- Weight: 21 oz.

PART NO.	DESCRIPTION
8.710-376.0	ST-2605
8.701-673.0	 Unitized Valve

**ST-2305 SUTTNER TRIGGER GUN** 

Extreme durability with easy pull trigger and ceramic ball in valve for higher chemical resistance.



- PSI: 5000
- GPM: 12
- Temperature: 300°F
- 3/8" FPT Inlet x 1/4" FPT Outlet
- Weight: 21 oz.

PART NO.	DESCRIPTION
8.710-386.0	ST-2305
8.701-673.0	Unitized Valve
8.701-674.0	Unitized Weep Valve

**ST-2000 SUTTNER TRIGGER GUN** 

15° offset angle thru gun for easier overhead use. The handle style for "Big Hands".



- PSI: 5000
- GPM: 10.4
- Temperature: 300°F
- 3/8" FPT Inlet x 1/4" FPT Outlet
- Weight: 26 oz.

PART NO.	DESCRIPTION
8.710-388.0	ST-2000
8.751-119.0	Unitized Valve - 5000 PSI
8.701-665.0	Unitized Weep Valve

**ST-1500 SUTTNER TRIGGER GUN** 

The perennial favorite for general pressure washer applications.



- PSI: 5000
- GPM: 10.4
- Temperature: 300°F
- 3/8" FPT Inlet x 1/4" FPT Outlet
- Weight: 20.5 oz.

PART NO.	DESCRIPTION
8.710-384.0	 ST-1500
8.710-385.0	ST-1500 with Weep
8.751-119.0	Unitized Valve - 5000 PSI
8.701-665.0	Unitized Weep Valve

**ST-2700 SUTTNER TRIGGER GUN** 

Relax action design, stainless-steel gun.



- PSI: 5000
- GPM: 12
- Temperature: 300°F
- 3/8" FPT Inlet x 1/4" FPT Outlet
- Weight: 21 oz.

PART NO.	DESCRIPTION
8.710-389.0	ST-2700
8.701-658.0	Unitized Valve

**ST-2315 SUTTNER TRIGGER GUN** 

Extreme durability with easy pull trigger.



- PSI: 5000
- GPM: 12
- Temperature: 300°F
- 3/8" FPT Inlet x 1/4" FPT Outlet
- Weight: 20.8 oz.

PART NO.	DESCRIPTION
9.106-073.0	ST-2315, Ceramic Ball Valve for Chemical and Acid Resistance



### PA TRIGGER GUN

Great for truck and fleet wash.



- PSI: 3200
- GPM: 8
- Temperature: 320°F
- 3/8" FPT Inlet x 1/4" FPT Outlet
- Weight: 10 oz.

PART NO.	DESCRIPTION
8.710-440.0	RL20
8.704-180.0	Repair Kit

Compact feel for smaller hands.



- PSI: 5000
- GPM: 10.5
- Temperature: 320°F
- 3/8" FPT Inlet x 1/4" FPT Outlet
- Weight: 26 oz.

PART NO.	DESCRIPTION
8.710-377.0	RL30-YG5000
8.704-616.0	Repair Kit



- PSI: 5000
- GPM: 10.5
- Temperature: 320°F
- 3/8" FPT Inlet x 1/4" FPT Outlet
- Weight: 27.5 oz.



PART NO.	DESCRIPTION
8.710-378.0	Vega 5000
8.704-232.0	Valve Kit Vega
8.704-615.0	Repair Kit

Easy pull and easy to hold with matching blue lance.



RL-56 Gun

- PSI: 5650
- GPM: 8
- Temperature: 320°F
- 3/8" FPT Inlet x 1/4" FPT Outlet
- Weight: 23.3 oz.
- Blue Vent Grip, Stainless-steel Lance has 1/4" BSP Threads



40" Stainless-Steel Blue Grip Lance

PART NO.	DESCRIPTION
9.802-227.0	RL-56 Blue Gun and Wand (nozzle protector not included)
8.710-446.0	RL-56 Blue Gun
8.710-645.0	40" Stainless-Steel Lance, blue vent grip (with nozzle protector)
8.704-610.0	Repair Kit, RL-55/RL-56

### PA LINEAR GUN

Ergonomic design minimizes fatigue for operator.



- PSI: 4500
- GPM: 10.5
- Temperature: 320°F
- 3/8" FPT Inlet x 1/4" FPT Outlet
- Weight: 19.2 oz.

PART NO.	DESCRIPTION
8.752-080.0	PA Linear Gun
9.801-398.0	PA Linear Gun Repair Kit

### SUTTNER TRIGGER GUN



15° offset angle thru gun for easier overhead use.



- PSI: 4000
- GPM: 12
- Temperature: 300°F
- 3/8" FPT Inlet x 1/4" FPT Outlet
- Weight: 23 oz.

PART NO.	DESCRIPTION
8.710-370.0	ST-601
8.751-119.0	Unitized Valve - 5000 PSI

### BIG GUN



- PSI: 3200
- GPM: 53
- Temperature: 210°F
- 3/4" FPT Inlet x 1/2" FPT Outlet
- Weight: 47.5 oz.

Model RL204



- PSI: 7250
- GPM: 21
- Temperature: 210°F
- 1/2" Stainless-Steel FPT Inlet / Outlet
- Weight: 60.3 oz.

Model RL84 "Big Black Gun"

PART NO.	DESCRIPTION
8.740-165.0	Model RL204
8.749-327.0	Repair Kit - Model RL204
8.704-136.0	Repair Kit - Model 100
8.704-612.0	Repair Kit - Model 160
8.710-445.0	Model RL84
8.750-459.0	Repair Kit - RL84

**ML320**

Excellent light-duty gun.



- PSI: 2320
- GPM: 6.6
- Temperature: 212°F
- 1/4" M Inlet x 1/4" F Outlet
- Weight: 8.82 oz.

PART NO.	DESCRIPTION
8.757-839.0	ML320

**OPEN GUNS**

Flow through design offers less downtime for repair

**AP1000 OPEN GUN**

Durable glass reinforced handle. Tubular flow-thru intervals for high pressure and efficiency.



- Temperature: 300°F
- 3/8" FPT Inlet x 1/4" FPT Outlet
- Weight: 16.7 oz.

PART NO.	DESCRIPTION
8.710-396.0	AP1000 Open Gun
8.750-951.0	AP1000 Weep Gun with Blue, Lock

**MV 925 OPEN GUN**

Just plain comfortable!



- Temperature: 300°F
- 3/8" FPT Inlet x 1/4" FPT Outlet
- Weight: 12.3 oz.

PART NO.	DESCRIPTION
8.754-988.0	MV925 without trigger

**ST-1500H OPEN GUN**



- Temperature: 300°F
- 3/8" FPT Inlet x 1/4" FPT Outlet
- Weight: 20.5 oz.

PART NO.	DESCRIPTION
8.710-383.0	ST-1500 Open Gun

**FLOW-THRU GUN**

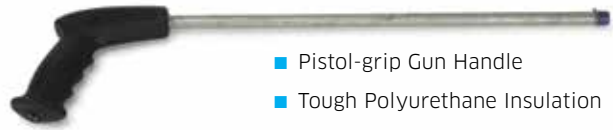

"Full" Grip

- Pistol-grip Gun Handle
- Tough Polyurethane Insulation
- Cushion Grip
- Full Grip or Slim Line Handle

PART NO.	DESCRIPTION
8.710-400.0	Full Black Grip 3/8" FPT x 1/4" FPT
<b>GUN HANDLE WITH 18" LANCE</b>	
8.710-403.0	Slim Red Grip 1/4" M x 1/4" F
8.710-404.0	Full Red Grip 3/8" F x 1/4" M

**AP DUMP GUN**

Water continues to run through the tube even when trigger gun is closed.



- PSI: 3000
- GPM: 10.5
- Temperature: 140°F
- 3/8" FPT Inlet x 1/8" FPT Outlet

PART NO.	DESCRIPTION	WEIGHT
8.710-405.0	Dump Gun 16" Lance	45.15 oz.
8.710-406.0	Dump Gun 40" Lance	59.61 oz.
8.704-169.0	Repair Kit	

**DUMP GUN**

Industrial duty dual-barrel.



- PSI: 3000
- GPM: 10
- Temperature: 200°F
- 3/8" FPT Inlet x 1/4" FPT Outlet
- Includes: QC Socket at Inlet and QC Plug at Outlet

PART NO.	DESCRIPTION
8.710-408.0	Dump Gun with 36" Barrel
8.700-311.0	Repair Kit

## LEGACY SUPERLITE STAINLESS-STEEL DUAL LANCE

Superlite stainless-steel with nozzle guard and 1/8" stainless-steel outlet tubing.

- PSI: 4000
- Temperature: 200°F
- 1/4" MPT Inlet
- Side Handle/Valve Actuator
- Forged Brass Valve Body with Viton Seal

PART NO.	DESCRIPTION
8.710-618.0	36" - 37.8 oz.
8.900-781.0	Seal Kit

## DUAL LANCES

Interpump Dual Lance. Excellent for downstream injector and zinc-plated for chemical resistance.



**36" Standard Dual Lance**  
8.710-612.0



**36" Dual Vented Lance**  
9.114-032.0

Dual Lance	Deluxe Dual Lance	Dual Vented Lance
■ PSI:4050	■ PSI:4050	■ PSI: 4050
■ GPM: 10.5	■ GPM: 10.5	■ GPM: 10.5
■ Temperature: 284°F	■ Temperature: 284°F	■ Temp; 284°F
■ Side Handle Valve Adjustment	■ Side Handle Valve Adjustment	■ 1/4" QC Nozzle Holder
■ 1/4" Male Inlet	■ 1/4" Male Inlet	■ 1/4" Soap Nozzle included
■ 1/4" Dual Outlet	■ 1/4" Dual Outlet	■ 1/4" MPT inlet *(Does not include male inlet QC
	■ Includes: 1/4" QC Brass Coupler, Brass Soap Nozzle	

PART NO.	DESCRIPTION
<b>DUAL LANCE</b>	
8.710-612.0	36" Standard
8.710-621.0	72" Extended
<b>DELUXE DUAL LANCE</b>	
8.904-281.0	72" Deluxe Extended
<b>DUAL VENTED LANCE</b>	
9.114-032.0	36" Dual Vented
<b>REPAIR KIT</b>	
8.900-135.0	Valve Repair Kit

## DUAL LANCES

Premium dual lance with stainless-steel inset.



**AL Premium Dual Lance**  
8.710-722.0



**AL Basic Dual Lance**  
8.710-724.0

Dual Lance	Premium Dual Lance
■ PSI: 3650	■ PSI: 4000
■ GPM: 10.5	■ GPM: 10.5
■ Temperature: 300°F	■ Temperature: 302°F
■ 1/4" Male Inlet	■ 1/4" Male Inlet
■ 1/4" F NPT Dual Outlet	■ Stainless Steel Seat & 40" Vented Grip
■ 40" Molded Grip	■ 1/4" Stainless-steel Tubes
■ 1/8" Zinc-plated Tubes	■ Includes: 1/4" QC Brass Socket for QC Nozzles, 1/8" 40 x 65° Brass Soap Nozzle, Nozzle Protector and Valve Cover (QC nozzles not included)

PART NO.	DESCRIPTION
<b>DUAL LANCE</b>	
8.710-724.0	40 " AL333 Basic Dual Lance
8.710-722.0	40" AL344LS-VPKIT Premium Dual Lance
8.904-360.0*	40" AL344LS-VPKIT Premium Dual Lance with 1/4" QC Brass Inlet Plug

<b>REPAIR KIT</b>	
8.720-548.0	Basic Repair Kit
9.803-267.0	Premium Repair Kit

\*Model includes a hardened-steel QC inlet plug.



## DUAL LANCES

Dual lances allow for easy switching between high pressure cleaning and low pressure chemical application (chemical injector required). Stainless steel pipes give increased life when applying variable Ph products.

### SUTTNER DUAL LANCES

High-pressure, thin-wall tubing and zinc / chromate finish.



ST-54 with Side Handle

- PSI: 4000 or 4500
- GPM: 10
- Temperature: 300°F

ST-53 with Knob

- 38" Total Length, Molded Grip
- Weight: 42 oz.

PART NO.	DESCRIPTION
8.710-613.0	ST-53 with Knob (4000 PSI)
8.710-614.0	ST-54 with Side Handle (4500)
8.701-594.0	Repair Kit (ST-53)
8.900-153.0	Clamp Kit (ST-53/54)
8.701-602.0	Repair Kit (ST-54)

### LEGACY SQUARE MOLDED GRIP LANCES

High-quality chrome-plate finish. Solid molded polymer construction and handle with hollow-rib for increased heat dissipation.



- PSI: 5250
- GPM: 12
- Temperature: 300°F
- 1/4" Male Inlet and Outlet

PART NO.	DESCRIPTION
8.752-898.0	Lance, Molded, 12"
8.752-899.0*	Lance, Molded, 20"
8.752-900.0	Lance, Molded, 24"
8.752-901.0	Lance, Molded, 28"
8.752-902.0*	Lance, Molded, 36"
8.752-903.0	Lance, Molded, 48"
8.752-904.0	Lance, Molded, 60"
8.752-905.0*	Lance, Molded, 79"

\*BENT VERSION AVAILABLE Call representative for pricing and to order.

### LEGACY OVAL MOLDED GRIP LANCES



A comfortable grip reducing fatigue and a stainless-steel or high-quality chrome-plated finish. Solid molded polymer construction and handle with hollow-rib for increased heat dissipation.



- PSI: 5250
- Temperature: 300°F
- 1/4" Male Inlet and Outlet

PART NO.	DESCRIPTION
<b>STAINLESS-STEEL</b>	
8.752-882.0	Lance, Molded, 12"
8.752-883.0*	Lance, Molded, 20"
8.752-884.0*	Lance, Molded, 24"
8.752-885.0	Lance, Molded, 28"
8.904-301.0	Lance, Molded, 28", Bent 15°
8.752-886.0*	Lance, Molded, 36"
8.752-887.0	Lance, Molded, 48"
8.904-303.0	Lance, Molded, 36", Bent 15°
8.752-888.0*	Lance, Molded, 60"
8.752-889.0*	Lance, Molded, 79"
<b>CHROME-PLATED</b>	
8.752-890.0	Lance, Molded, 12"
8.752-891.0	Lance, Molded, 20"
8.752-892.0*	Lance, Molded, 24"
8.752-893.0	Lance, Molded, 28"
8.752-894.0	Lance, Molded, 36"
8.752-906.0	Lance, Molded, 36", with handle
8.904-324.0	Lance, Molded, 36", with handle, Bent 15°
8.752-895.0	Lance, Molded, 48"
8.752-907.0	Lance, Molded, 48", with handle
8.752-896.0	Lance, Molded, 60"
8.752-897.0	Lance, Molded, 79"

\*BENT VERSION AVAILABLE Call representative for pricing and to order.

### SUTTNER LANCES

High-pressure, thin-wall tubing and zinc / chromate finish..



PART NO.	DESCRIPTION
<b>15 DEG BENT</b>	
9.113-700.0	Molded 36" SS 6000 PSI
9.113-701.0	Molded 48" SS 6000 PSI
<b>STRAIGHT</b>	
9.113-704.0	Molded Grip 48" SS Lance 6000
9.113-705.0	Molded Grip 36" SS Lance, 6000



### AP UNINSULATED LANCES

Stainless-steel or corrosion-resistant, bright zinc-plated lances made with 1/4" high-pressure, lightweight, thin-wall tubing and superior strength rolled threads.



- PSI: 4100
- Temperature: 300°F

PART NO.	DESCRIPTION
<b>STAINLESS-STEEL</b>	
8.710-623.0 <b>S</b>	Length, 12"
8.710-624.0*	Length, 20"
8.710-625.0*	Length, 24"
8.710-626.0	Length, 28"
8.710-627.0 <b>S</b>	Length, 36"
8.710-628.0 <b>S</b>	Length, 48"
8.710-629.0	Length, 60"
8.710-630.0	Length, 78"
<b>ZINC-PLATED</b>	
8.710-631.0	Length, 12"
8.710-632.0	Length, 20"
8.710-633.0 <b>S</b>	Length, 24"
8.710-634.0* <b>S</b>	Length, 36"
8.710-635.0* <b>S</b>	Length, 48"
8.710-636.0 <b>S</b>	Length, 60"
8.710-637.0 <b>S</b>	Length, 78"

\*BENT VERSION AVAILABLE Call representative for pricing and to order.

### LEGACY VENTED LANCES

Stainless-steel or high-quality chrome-plate finish with molded glass-filled polyamide handle for heat dissipation with hollow insulators for increased heat venting.



- PSI: 5250
- Nozzle Protector Included
- Temperature: 300°F
- 1/4" Male Inlet, 1/4" Female Outlet

PART NO.	DESCRIPTION
<b>STAINLESS-STEEL</b>	
8.752-868.0	Lance, Vented, 20"
8.752-869.0	Lance, Vented, 24"
8.752-871.0 <b>S</b>	Lance, Vented, 36"
8.752-872.0	Lance, Vented, 48"
8.752-873.0	Lance, Vented, 60"
8.752-874.0	Lance, Vented, 79"
<b>CHROME-PLATED</b>	
8.752-875.0	Lance, Vented, 20"
8.752-876.0	Lance, Vented, 24"
8.752-878.0	Lance, Vented, 36"
8.752-879.0	Lance, Vented, 48"
8.752-880.0	Lance, Vented, 60"
8.752-881.0	Lance, Vented, 79"

### SUTTNER PUSH AND PULL LANCE



Vented grip can be pushed and pulled up to 90°. For hard to reach applications, such as gutters, fenders, trucks and heavy equipment.



- PSI: 3050
- Temperature: 300°F
- 3/4" Stainless-Steel Lance

PART NO.	DESCRIPTION
8.710-711.0	ST-85 Push and Pull Lance
8.710-720.0	Handle, Side

### BIG STAINLESS-STEEL LANCES & SIDE HANDLES

For big guns! Complete with an adjustable handle and coupler for 1/4" MPT nozzle and high-pressure stainless-steel pipe.



- Temperature: 300°F
- Schedule 40 Pipe
- 1/2" MPT Gun Connection

PART NO.	DESCRIPTION	PSI
8.904-081.0	20" Wand with Handle	4050
8.904-083.0	40" Wand with Handle	4050
8.904-086.0	Side Handle Only	-
8.710-411.0	39", Stainless-steel, 300°F, 8700 Inlet 1/2" MNPT, Outlet 1/4" MNPT	

### LANCE HANDLES / ACCESSORIES

Vented grip, side handle with nut, and vented grip with side handle, can be user-attached to uninsulated lances or 1/4" steel pipe. Detachable and reusable!



PART NO.	DESCRIPTION
8.710-717.0	Vent Grip Only (14" long)
8.904-357.0	Grip with Side Handle

PART NO.	DESCRIPTION
8.710-716.0	Vent Grip Only (14" Long) ST-9
8.710-719.0	Grip with Side Handle
8.710-720.0	Side Handle with Nut





### MV LANCE HANDLE



- Use On All 1/4" Lances
- Easily Positioned without Removal of Nozzle

PART NO.	DESCRIPTION
8.704-162.0	1/4" Lance Handle

### GUTTER CLEANER ATTACHMENT

Easily quick connect to any lance or extension wand to clean gutters or hard to reach areas. The angle improves reach and expands cleaning capabilities. For use with 5.0 or larger nozzle.



- PSI: 3500
- Temperature: 200°F
- Zinc-Plated
- Inlet 1/4" F Socket
- Outlet 1/4" M Plug

PART NO.	DESCRIPTION
8.711-324.0	1/4" Nipple x 1/4" QC

### FIBERGLASS TELESCOPING WANDS

High-quality telescoping wand can reach up to 24' with three sizes to choose from. A lightweight wand that is balanced under pressure.



Belt and Pole Clamp

- PSI: 4000
- GPM: 10.5
- Temperature: 195°F
- 6' - 12' Wand Shown



Telescoping Wand

PART NO.	DESCRIPTION
8.710-589.0	6'-12'
8.710-590.0	6'-18'
8.710-591.0	8-24'
8.700-059.0	Strap and Belt Shoulder Harness
8.711-324.0	Gutter Cleaning Attachment
8.723-896.0	TS12 Replacement Gun
8.710-595.0	TS18 Replacement Gun
8.739-434.0	TS24 Replacement Gun

### SPRAY-FLEX™ FLEX WAND

Access difficult spots easily. Great for cleaning engines, roofs, eaves, or underneath almost anything! Holds its shape under pressure.



- PSI: 3000 or 5000
- Temperature: 190°F
- 90° Flexibility
- 12" 1/4" NPT x 1/4" NPT

PART NO.	DESCRIPTION
8.710-597.0	3000 PSI
8.710-596.0	5000 PSI

### FLEX LANCES

Save on broken wand repairs! Flexes a full 180° and returns, preventing bent lances and broken hose. Ideal for self-serve car wash bays.



- PSI: 2500
- Industrial-Grade Polyurethane Flex Section
- Temperature: 200°F
- Galvanized Pipe Ends

PART NO.	DESCRIPTION
8.710-598.0	<b>S</b> 18", 1/4" MPT x 1/4" MPT
8.710-603.0	21", 1/4" MPT x 1/8" FPT
8.710-604.0	24", 1/4" MPT x 1/8" FPT

### HOBBY GUN, LANCE AND HOSE

Don't turn away hobby-unit owners. Complete replacement hose, gun and lance.



#### Insulated Lance with Gun

- PSI: 4500
- GPM: 8
- Temperature: 320 F
- 3/8" NPT Inlet

#### Lance with Coupler

- PSI: 3000
- Temperature: 140 F

#### Lance with 3 Hi/Low Varifan Nozzle

- PSI: 2000
- GPM: 5.5

#### 1/4" x 25" Thermoplastic

- PSI: 3600
- Temperature: 140 F

PART NO.	DESCRIPTION
8.754-769.0	Insulated Lance with Gun
8.753-272.0	18" Lance with #3 Hi / Low Varifan Nozzle
8.753-423.0	1/4"x25" Thermoplastic, 22mm both ends

NOTE: See page 140 for more Hobby Hose

### GUN, DUAL LANCE COMBO

- PSI: 5000
- GPM: 12



PART NO.	DESCRIPTION
8.930-771.0	36" with 5000 psi 12 GPM gun TBD

### LEGACY INDUSTRIAL GUN AND LANCE COMBO



Gun and lance combo with 36" square-molded grip lance and 1/4" quick coupled socket. Includes nozzle protector.



- PSI: 5000
- GPM: 10.4
- Temperature: 300°F
- Zinc-Plated Steel Tubes
- Stainless-Steel Seat
- Weight: 39 oz.

PART NO.	DESCRIPTION
8.904-095.0	<b>S</b> Legacy Gun and Lance with 3/8" MPT QC Inlet

### MV925 GUN AND LANCE COMBO

Gun and lance combo with pre-assembled 36" square grip lance.



- PSI: 4500
- GPM: 8.0
- 1/4" FPT QC Socket Installed on Outlet of Lance
- 3/8" MPT QC Nipple Installed on Inlet of Gun

PART NO.	DESCRIPTION
8.928-442.0	<b>S</b> MV925 Gun

### MV925 GUN, LANCE AND HOSE COMBO

Gun, lance and hose combo with 36" square grip lance and 50' hose.



- PSI: 4000
- GPM: 8
- 3/8" MPT QC Nipple Installed on Inlet of Gun
- R1 4000 PSI 3/8" x 50' Black Hose
- 1/4" FPT QC Socket Installed on Outlet of Lance
- 3/8" FPT QC Sockets Installed on Hose

PART NO.	DESCRIPTION
8.928-443.0	MV925 Gun

**HOSE - LEGACY HIGH-PRESSURE**



For use with hot or cold-water pressure washers. The Legacy hose is built to exceed the EN1829-2 Standard and will provide superior abrasion resistance that will increase the life of the hose.

Both single-and double-wire braid hoses come with durable 8" bend restrictors on both ends. The Legacy hose has a "bite-the -wire" coupling that grips the hose better than any other design and is far superior to the "compression fittings" used on conventional hoses.

- Easily Identified: Permanently embossed identification makes for easy tracing and owner protection.
- This heavy duty hose is reinforced with braided, high tensile steel wire and a very durable cover.



**HOSE - 1-WIRE**



- Rated to 250°F
- Smooth impression, oil resistant tube and **Black Hose Guard** at both ends

**HOSE - 2-WIRE**



- Rated to 250°F
- Smooth impression, oil resistant tube and **Red Hose Guard** at both ends

PART NO.	SIZE	PSI
<b>3/8" MPT SWIVEL X 3/8" MPT SOLID, 3/8" ID</b>		
8.925-176.0	3/8" x 15'	4000
8.925-150.0	3/8" x 25'	4000
8.925-156.0	3/8" x 50'	4000
8.925-161.0	3/8" x 75'	4000
8.925-165.0	3/8" x 100'	4000
8.925-170.0	3/8" x 150'	4000
8.925-350.0	3/8" x 200'	4000
8.925-378.0	Case of 75 (8.925-156.0) 3/8" x 50' Hoses	
8.925-449.0	Case of 40 (8.925-165.0) 3/8" x 100' Hoses	
<b>3/8" MPT SWIVEL X 3/8" MPT SWIVEL, 3/8" ID</b>		
8.925-364.0	3/8" x 50'	4000
8.925-365.0	3/8" x 75'	4000
8.925-167.0	3/8" x 100'	4000
8.925-367.0	3/8" x 150'	4000
8.925-368.0	3/8" x 200'	4000
<b>1/4" MPT SWIVEL X 1/4" MPT, SOLID, 1/4" ID</b>		
8.925-143.0	1/4" x 25'	4000
8.925-144.0	1/4" x 30'	4000
8.925-145.0	1/4" x 50'	4000
8.925-146.0	1/4" x 75'	4000
8.925-147.0	1/4" x 100'	4000
<b>1/2" MPT SWIVEL X 1/2" MPT SOLID</b>		
8.925-236.0	50'	3000
8.925-237.0	75'	3000
8.925-238.0	100'	3000
<b>BLACK WRAPPED HOSE SWXSO</b>		
9.113-845.0	3/8" x 50'	4000
9.113-846.0	3/8" x 100'	4000

PART NO.	SIZE	PSI
<b>3/8" MPT SWIVEL X 3/8" MPT SOLID, 3/8" ID</b>		
8.928-542.0	3/8" x 15'	6000
8.925-180.0	3/8" x 25'	6000
8.925-184.0	3/8" x 50'	6000
8.925-225.0	3/8" x 75'	6000
8.925-229.0	3/8" x 100'	6000
8.925-232.0	3/8" x 150'	6000
8.925-369.0	3/8" x 200'	6000
8.925-382.0	Case of 75 (8.925-184.0) 3/8" x 50' Hoses	
8.925-450.0	Case of 40 (8.925-229.0) 3/8" x 100' Hoses	
<b>3/8" MPT SWIVEL X 3/8" MPT SWIVEL, 3/8" ID</b>		
8.925-311.0	3/8" x 25'	6000
8.925-313.0	3/8" x 50'	6000
8.925-314.0	3/8" x 75'	6000
8.925-316.0	3/8" x 100'	6000
8.925-325.0	3/8" x 200'	6000
<b>1/2" MPT SWIVEL X 1/2" MPT SOLID</b>		
8.925-247.0	1/2" x 50'	5000
8.925-249.0	1/2" x 75'	5000
8.925-253.0	1/2" x 100'	5000
<b>BLACK WRAPPED HOSE SWXSO</b>		
9.113-847.0	3/8" x 50'	6000
9.113-848.0	3/8" x 100'	6000

1,000 FOOT REELS

<b>9.113-139.0</b>	3/8" Hose R1	4000 PSI	Black
<b>9.113-140.0</b>	3/8" Hose R2	6000 PSI	Black
<b>9.113-141.0</b>	1/4" Hose R1	4000 PSI	Black



Note: Full Reel - 1000 ft per reel, hose only. Max of 3 incremental cuts per reel, industry standard. Call your sales representative for pricing.

## HOSE - LEGACY 1- & 2-WIRE WITH COUPLERS





- Temperature: 250°F
- Coupler and Plug Included
- 3/8" ID - Solid / Swivel & Swivel / Swivel options available



PART NO.	LENGTH	DESCRIPTION	WORKING PSI	APPROX WT (LBS.)
<b>3/8" BLACK HOSE, R1</b>				
8.928-928.0	 50'	3/8" ID Solid X Swivel	4000	13.0
8.928-929.0	100'	3/8" ID Solid X Swivel	4000	24.0
8.930-772.0	50'	Swivel X Swivel	4000	
8.930-773.0	100'	Swivel X Swivel	4000	
<b>3/8" BLACK HOSE, R2</b>				
8.928-930.0	 50'	3/8" ID Solid X Swivel	6000	18.0
8.928-931.0	100'	3/8" ID Solid X Swivel	6000	33.0
8.930-774.0	50'	Swivel X Swivel	6000	
8.930-775.0	100'	Swivel X Swivel	6000	

## HOSE - GRAY NON-MARKING 1 & 2-WIRE

- Tough, Abrasive Resistant Wrapped Cover
- Oil Resistant Non-Marking
- For use with Hot or Cold Water
- 3/8" MPT Solid X 3/8" Swivel Ends



PART NO.	LENGTH	DESCRIPTION	WORKING PSI	APPROX WT (LBS.)
<b>3/8" GRAY HOSE, R1</b>				
9.114-440.0	 50'	3/8" ID	4200	12
9.114-441.0	100'	3/8" ID	4200	24
<b>3/8" GRAY HOSE, R2</b>				
9.114-442.0	 50'	3/8" ID	6000	19
9.114-443.0	100'	3/8" ID	6000	36

## HOSE - LEGACY 1-WIRE SMOOTH COVER, NON-MARKING



- Temperature: 250°F
- 1/4" & 3/8" Smooth Non-Marking
- 3/8" MPT Solid X 3/8" Swivel Ends



PART NO.	LENGTH	DESCRIPTION	WORKING PSI	APPROX WT (LBS.)
<b>3/8" SMOOTH YELLOW HOSE</b>				
8.901-800.0	50' x 3/8" ID		3000	12.0
8.901-802.0	75' x 3/8" ID		3000	17.0
8.901-804.0	100' x 3/8" ID		3000	23.0
8.757-441.0	500' Reel		3000	115.0
<b>3/8" SMOOTH BLUE HOSE</b>				
8.739-148.0	50' x 3/8" ID		3000	12.0
8.739-149.0	75' x 3/8" ID		3000	17.0
8.739-150.0	100' x 3/8" ID		3000	23.0
8.739-369.0	 150' x 3/8" ID		3000	34.0
8.925-296.0	200' x 3/8" ID		3000	45.0
8.757-442.0*	500' Reel		3000	115.0
<b>3/8" SMOOTH GRAY HOSE</b>				
8.749-935.0	50' x 3/8" ID		3000	13.0
8.749-936.0	100' x 3/8" ID		3000	25.0
8.757-443.0*	500' Reel		3000	125.0
<b>1/4" SMOOTH BLUE HOSE</b>				
8.901-796.0	 50' x 1/4" ID		3000	8.0
8.901-798.0	 100' x 1/4" ID		3000	16.0

\*Full Reel - 500 ft per reel, hose only. Max of 3 incremental cuts per reel, industry standard.

**HOSE - LEGACY 1- & 2-WIRE, NON-MARKING**



- Temperature: 250°F
- Blue Smooth Non-Marking
- SO / SW Couplers Not Included



PART NO.	LENGTH	WORKING PSI	APPROX WT (LBS.)
<b>3/8" SMOOTH BLUE HOSE - R2</b>			
8.739-229.0	S 50' R2	4500	17.0
8.739-231.0	S 100' R2	4500	33.0
8.925-320.0	150' R2	4500	
8.757-438.0*	500' Reel	4500	165.0
<b>1/2" SMOOTH BLUE HOSE - R1</b>			
8.925-300.0	1/2" x 75'	3000	25.0
8.757-439.0*	500' Reel	3000	167.0

\*Full Reel - 500 ft per reel, hose only. Max of 3 incremental cuts per reel, industry standard.

**HOSE - A+ 1-WIRE GRAY SMOOTH COVER, NON-MARKING**



- Temperature: 250°F
- 3/8" MPT Swivel x 3/8" MPT Solid



PART NO.	LENGTH	DESCRIPTION	PSI	APPROX WT (LBS.)
<b>3/8" SMOOTH COVER, GRAY HOSE</b>				
8.921-617.0	3/8" x 25'	4K Gray A+ SOXSW	4000	6.0
8.921-618.0	3/8" x 50'	4K Gray A+ SOXSW	4000	11.0
8.921-619.0	3/8" x 75'	4K Gray A+ SOXSW	4000	17.0
8.921-620.0	3/8" x 100'	4K Gray A+ SOXSW	4000	33.0
8.752-156.0*	600' Reel	4K Gray A+	4000	165.0

\*Full Reel - 600 ft per reel, hose only. Max of 3 incremental cuts per reel, industry standard.

**HOSE - A+ 1- & 2-WIRE WITH COUPLING AND PLUG, NON-MARKING**



- Temperature: 250°F
- Couplers and Plug Included
- 3/8" MPT Swivel x 3/8" MPT Solid



PART NO.	LENGTH	WORKING PSI	APPROX WT (LBS.)
<b>3/8" 1-WIRE BLUE HOSE</b>			
8.928-971.0	50' x 3/8" ID	4000	13.0
8.928-972.0	100' x 3/8" ID	4000	23.0
<b>3/8" 2-WIRE BLUE HOSE</b>			
8.928-973.0	50' x 3/8" ID	6000	18.0
8.928-974.0	100' x 3/8" ID	6000	33.0

**HOSE - A+ / TUFF-FLEX - 1-WIRE SMOOTH COVER, NON-MARKING**



- Temperature: 250°F
- 50% Greater Flexibility
- 3/8" MPT Swivel x 3/8" MPT Solid
- Smooth impression, maximum oil-resistant tube and cover



PART NO.	LENGTH	WORKING PSI	APPROX WT (LBS.)
<b>3/8" TUFF-FLEX 1-WIRE BLUE HOSE</b>			
8.921-149.0	25' x 3/8" ID	4000	6.0
8.921-150.0	S 50' x 3/8" ID	4000	11.0
8.921-151.0	75' x 3/8" ID	4000	17.0
8.921-152.0	S 100' x 3/8" ID	4000	23.0
8.753-316.0*	600' Reel	4000	138.0

\*Full Reel - 600 ft per reel, hose only. Max of 3 incremental cuts per reel, industry standard.



## HOSE - A+ / TUFF-FLEX - 2-WIRE SMOOTH COVER, NON-MARKING

- Temperature: 250°F
- 50% Greater Flexibility

- 3/8" MPT Swivel x 3/8" MPT Solid
- Smooth impression, maximum oil-resistant tube and cover



PART NO.	LENGTH	WORKING PSI	APPROX WT (LBS.)
<b>3/8" TUFF-FLEX 2-WIRE BLUE HOSE</b>			
8.921-153.0	25' x 3/8" ID	6000	9.0
8.921-154.0	<b>S</b> 50' x 3/8" ID	6000	18.0
8.921-155.0	75' x 3/8" ID	6000	24.0
8.921-156.0	100' x 3/8" ID	6000	33.0
8.753-319.0	600' Reel	6000	198.0

\*Full Reel - 600 ft per reel, hose only. Max of 3 incremental cuts per reel, industry standard.

## PRESSURE LOOP - 2-WIRE

The 1/4" ID pressure lines solid / swivel for most any application. The 3/8" ID pressure loops have 1/2" female JIC swivels on both ends for typical unloader connection hose.



- 1/4" ID Pressure Loop
- 1/4" MPT Swivel x 1/4" MPT Solid
- 1/4" ID Two-Wire, 6000 PSI
- Temperature: 250°F



- JIC Pressure Loop
- 1/2" Female JIC Swivels - Each End
- 3/8" ID Two-Wire, 6000 PSI
- 1/2" ID 5000 PSI
- Temperatures:  
250°F (3/8" Pressure Loop)  
275°F (1/2" Pressure Loop)

PART NO.	LENGTH	PSI
<b>1/4" PRESSURE LOOP</b>		
8.918-180.0	16" x 1/4" ID	6000
8.918-181.0	20" x 1/4" ID	6000
8.918-182.0	26" x 1/4" ID	6000
8.918-183.0	28" x 1/4" ID	6000
8.918-184.0	30" x 1/4" ID	6000
8.918-419.0	36" x 1/4" ID	6000
8.918-187.0	42" x 1/4" ID	6000

PART NO.	LENGTH	PSI
<b>3/8" JIC PRESSURE LOOP</b>		
8.918-210.0	16" x 3/8" ID	6000
8.918-422.0	20" x 3/8" ID	6000
8.918-423.0	22" x 3/8" ID	6000
8.918-424.0	<b>S</b> 25" x 3/8" ID	6000
8.918-425.0	29" x 3/8" ID	6000
8.918-426.0	32" x 3/8" ID	6000
8.918-427.0	36" x 3/8" ID	6000
8.918-212.0	42" x 3/8" ID	6000
<b>1/2" JIC PRESSURE LOOP</b>		
8.918-224.0	20" x 1/2" ID	5000
8.918-225.0	28" x 1/2" ID	5000
8.918-228.0	46" x 1/2" ID	5000
8.918-230.0	70" x 1/2" ID	5000



## HOSE - WHITEWATER® COMBINATION STEAM HOSE



Good up to 3000 PSI - 250°F or 2500 PSI - 325°F



- Single High-Tensile Steel Wire Braid
- High Temperature Bend Restrictors - Both Ends
- Seamless Innertube
- Solid 3/8" or 1/2" MPT Connectors - Both Ends (Swivel Ends NOT Available)
- Oil-Resistant Cover

PART NO.	LENGTH	WORKING PSI
<b>3/8" STEAM HOSE</b>		
8.901-598.0	25'	3000
8.901-601.0	50'	3000
8.901-603.0	75'	3000
8.901-604.0	100'	3000
8.930-657.0	200'	3000
8.705-643.0*	500' Reel	3000
<b>1/2" STEAM HOSE</b>		
8.901-721.0	25'	2500
8.901-723.0	50'	2500
8.901-724.0	75'	2500
8.901-725.0	100'	2500
8.705-678.0*	500' Reel	2500

\*Full Reel - 500 ft per reel, hose only. Max of 3 incremental cuts, industry standard.

## PULSE HOSE



- PSI Working Pressure: 1300
- 3/8" MPT On Both Styles
- Available with either plug-end or open-flow with solid / swivel connects

PART NO.	LENGTH	DESCRIPTON
8.711-151.0	18"	with Plug End, Working PSI: 1300 PSI
8.711-153.0	24"	with Plug End, Working PSI: 1300 PSI
8.711-155.0	28"	Solid / Swivel - Open, Working PSI: 1300 PSI
8.711-157.0	36"	Solid / Swivel - Open, Working PSI: 1300 PSI

## HOSE BEND RESTRICTORS



- Temperature: 325°F
- Used on Hose Assemblies
- Non-Slip Sure Fit
- Easy Installation
- Top-Quality Molded Fit Bend Restrictors
- Fits snugly to prevent kinks near the connectors
- Insulated Rubber

PART NO.	LENGTH	COLOR
<b>1 WIRE</b>		
8.705-479.0	5.3" x 1/4"	Black Vinyl
8.705-476.0	6.0" x 1/2"	Black Vinyl
8.740-104.0	24.0" x 3/8"	Black Vinyl
8.756-784.0	6.0" x 3/8"	Black Vinyl
<b>2 WIRE</b>		
8.756-735.0	1/2" x 8"	Red Vinyl
8.705-478.0	6.0" x 3/8"	Red Vinyl
8.711-846.0	24.0" x 3/8"	Red Vinyl
8.705-480.0	7.0" x 3/8"	Red Vinyl
<b>COMBO - HIGH TEMP</b>		
8.705-483.0	6.5" x 3/8" ID	Gray Vinyl
8.705-482.0	6.5" x 1/2" ID	Black Rubber

## HOBBY HOSE

Replacement hose for most hobby pressure washers sold by retailers.

- PSI Working Pressure: 2250
- PSI Burst Pressure: 9000
- Thermoplastic Cover
- Fiber-braid Reinforcement
- M22 x 1.5 Fitting Inlet
- 14 mm Seal Cone Fits Generac, Excell and Kärcher
- 15 mm Seal Cone Fits Campbell, MI-T-M



PART NO.	LENGTH	SEAL CONE	ID
8.705-485.0	25'	14mm	1/4"
8.705-487.0	25'	15mm	1/4"
8.753-423.0	25'	22mm	1/4"

### GARDEN HOSE - APEX QUALITY

The essential product for pressure washing



- Rated For Cold-Water Use
- Assemblies Complete With Bend Restrictor
- 5/8" or Larger ID For Full Flow
- Choice of Commercial or Heavy-Duty Grade
- Reinforced hose for flexibility and strength in all weather
- Commercial grade has machined octagonal "wrench tight" fittings

PART NO.	LENGTH	GRADE	COLOR
8.704-786.0	50' x 5/8" ID	Com	Gray
8.704-787.0	100' x 5/8" ID	Com	Gray
8.704-788.0	50' x 5/8" ID	HD	Light Green
8.704-789.0	100' x 5/8" ID	HD	Light Green
<b>ALL RUBBER REINFORCED HOT WATER HOSE - 160°F</b>			
8.704-790.0	50' x 5/8" ID	Com	Red
8.704-791.0	50' x 3/4" ID	Com	Red

See page 154 for garden hose fittings

### GARDEN HOSE - COLD WEATHER



- Ideal for outdoor contractors
- 5/8" x 50 ft
- High-Quality Brass Fittings
- Heated Hose with 110 Plug
- Thermostatically controlled - heating element is activated at +/- 35°F temperature and turned off at +/- 40°F ambient temperature
- Use only with a UL approved GFCI outlet or extension
- PVC material FDA-approved for potable water

PART NO.	LENGTH	DESCRIPTION
8.749-944.0	5/8" x 50'	Cold Weather Garden Hose

See page 154 for garden hose fittings

### AG HOSE - ORANGE PVC-RIBBED - BULK

Braid-reinforced PVC hose designed specifically for AG / Pest Control and Lawn Spraying applications.

- Max PSI: 600
- Max Temperature: 160°F
- Color: Orange
- Tough Ribbed Cover
- Bulk hose standard in 300' single length coils
- Resists Abrasion and UV Rays
- Does Not Include Ends or Bend Restrictors

PART NO.	LENGTH	PSI
<b>3/8" HOSE - ORANGE</b>		
8.705-527.0	300' Coil, Single, Uncut Length	600
8.901-384.0	50' Bulk	600
8.901-385.0	100' Bulk	600
<b>1/2" HOSE - ORANGE</b>		
8.705-523.0 	300' Coil, Single, Uncut Length	600
8.901-377.0	50' Bulk	600
8.901-379.0	100' Bulk	600
<b>3/4" HOSE - ORANGE</b>		
8.705-531.0	300' Coil Single, Uncut Length	600

### AG HOSE - COMPLETE ASSEMBLY

Braid-reinforced PVC hose designed specifically for AG / Pest control spraying applications. Assembled with ends or bend restrictors.



- Max PSI: 600
- Max Temperature: 160°F
- Color: Orange
- Tough Ribbed Cover
- Resists Abrasion and UV Rays
- Includes Ends and 8" Black Bend Restrictors on Each End

PART NO.	LENGTH	DESCRIPTION
8.928-576.0	3/8" x 100'	SO x SW
8.928-577.0	3/8" x 100'	SW x SW
8.928-578.0	3/8" x 50'	SO x SW
8.928-579.0	1/2" x 50'	SO x SW
8.928-580.0	1/2" x 100'	SO x SW
8.928-581.0	1/2" x 300'	SO x SW

**CRIMP FITTINGS**



PART NO.	SIZE	HOSE
8.724-027.0	3/8" MPT, Solid	3/8"
8.724-028.0	3/8" MPT, Swivel	3/8"
8.724-029.0	1/2" FJIC, Solid	3/8"
8.706-759.0	3/8" FPT, Swivel	3/8"

**TUBING - CLEAR REINFORCED PVC**

Multi-use, industrial-grade tubing with high-resistance to chemicals, solvents and fuel.



- Reinforced With Polyester Cord
- Huge Selection of Sizes and Lengths
- 4-to-1 Burst Safety Factor

PART NO.	ID X OD	WP AT 70°F	LENGTH
8.901-256.0	1/4" x 3/8"	250	25'
8.901-257.0	1/4" x 3/8"	250	50'
8.704-751.0	1/4" x 3/8"	250	100'
8.704-752.0	<b>S</b> 1/4" x 3/8"	250	300'
8.901-260.0	3/8" x 1/2"	175	25'
8.901-261.0	3/8" x 1/2"	175	50'
8.901-262.0	3/8" x 1/2"	175	100'
8.704-753.0	3/8" x 1/2"	175	300'
8.901-264.0	1/2" x 3/4"	175	25'
8.901-265.0	1/2" x 3/4"	175	50'
8.704-754.0	1/2" x 3/4"	175	100'
8.704-755.0	<b>S</b> 1/2" x 3/4"	175	300'
8.901-267.0	5/8" x 7/8"	175	25'
8.901-268.0	5/8" x 7/8"	140	50'
8.901-269.0	5/8" x 7/8"	140	100'
8.704-756.0	5/8" x 7/8"	140	300'
8.901-271.0	3/4" x 1"	140	25'
8.901-272.0	3/4" x 1"	140	50'
8.704-757.0	3/4" x 1"	140	100'
8.704-758.0	3/4" x 1"	140	300'
8.901-273.0	1" x 1-1/4"	75	25'
8.901-274.0	1" x 1-1/4"	75	50'
8.901-275.0	1" x 1-1/4"	75	100'
8.704-759.0	1" x 1-1/4"	75	200'

See page 155 for hose clamps

**COUPLINGS - FIELD ATTACHABLE**

Designed and build your own hose or adapt and repair hose in the field (no crimper required).



PART NO.	ID X MPT
<b>1-WIRE BRAID HOSE COUPLINGS</b>	
8.705-493.0	<b>S</b> 1/4" x 1/4", Solid
8.705-495.0	1/4" x 1/4", Swivel
8.705-496.0	3/8" x 1/4", Solid
8.705-497.0	<b>S</b> 3/8" x 3/8", Solid
8.705-498.0	<b>S</b> 3/8" x 3/8", Swivel
8.705-499.0	1/2" x 3/8", Solid
8.705-500.0	1/2" x 1/2", Solid
8.705-501.0	1/2" x 1/2", Swivel
<b>2-WIRE BRAID HOSE COUPLINGS</b>	
8.705-502.0	1/4" x 1/4", Solid
8.705-503.0	1/4" x 1/4", Swivel
8.705-505.0	<b>S</b> 3/8" x 3/8", Solid
8.705-506.0	<b>S</b> 3/8" x 3/8", Swivel
8.705-507.0	1/2" x 1/2", Solid
8.705-508.0	1/2" x 1/2", Swivel

**TUBING - CLEAR PVC**



- "Box Pak" 100 ft
- Temperature: 25°F to 150°F
- Very Flexible, Non-Reinforced
- Self-dispensing Box Packaging

PART NO.	ID X OD	WP AT 70°F
8.901-279.0	1/4" x 3/8"	55
8.704-766.0	1/2" x 5/8"	30

**TUBING - HEAVY-DUTY VINYL**

This clear vinyl tubing is heavier duty than the rest! Thick wall resists kinking. Available in clear or clear-reinforced polyester braid. Comes in 1/4" & 3/8" ID x 1/2" OD.



- Very Flexible
- 100' Rolls
- Temperature: -10 to 150°F

PART NO.	ID X OD	PSI	DESCRIPTION
9.113-131.0	1/4" x 1/2"	50	Clear Vinyl
9.113-132.0	1/4" x 1/2"	250	Braided Vinyl
9.113-133.0	3/8" x 1/2"	100	Clear Vinyl



## CONNECTOR HOSE - 2' - 10'

Hose come with One Solid x One Swivel MPT crimp fitting on each end.



- PSI: 4000 - 6000
- Temperatures:  
250°F (1/4" & 3/8" Connector Hoses)  
275°F (1/2" Connector Hose)

PART NO.	LENGTH	PSI	HOSE COLOR
<b>3/8" ULTIMA - 1-WIRE WITHOUT BEND RESTRICTORS</b>			
8.918-253.0	2'	4000	Black
8.918-255.0	3'	4000	Black
8.918-257.0	4'	4000	Black
8.918-259.0	5'	4000	Black
8.918-261.0	6'	4000	Black
8.918-263.0	7'	4000	Black
8.918-265.0	8'	4000	Black
8.918-267.0	9'	4000	Black
8.918-269.0	10'	4000	Black
<b>1/4" ULTIMA - 1-WIRE WITHOUT BEND RESTRICTORS</b>			
8.918-240.0	2'	4000	Black
8.918-241.0	3'	4000	Black
8.918-242.0	4'	4000	Black
8.918-243.0	5'	4000	Black
8.918-245.0	6'	4000	Black

PART NO.	LENGTH	PSI	HOSE COLOR
<b>3/8" ULTIMA - 2-WIRE - WITHOUT BEND RESTRICTORS</b>			
8.918-271.0	2'	6000	Black
8.918-273.0	3'	6000	Black
8.918-276.0	4'	6000	Black
8.918-278.0	5'	6000	Black
8.918-280.0	6'	6000	Black
8.918-282.0	7'	6000	Black
8.918-284.0	8'	6000	Black
8.918-420.0	9'	6000	Black
8.918-288.0	10'	6000	Black
<b>3/8" ULTIMA - 2-WIRE - WITH BEND RESTRICTORS</b>			
8.918-272.0	2'	6000	Black
8.918-275.0	3'	6000	Black
8.918-277.0	4'	6000	Black
8.918-209.0	5'	6000	Black
8.918-281.0	6'	6000	Black
8.918-283.0	7'	6000	Black
8.918-285.0	8'	6000	Black
8.918-287.0	9'	6000	Black
8.918-289.0	10'	6000	Black
<b>1/2" ULTIMA - 2-WIRE - WITHOUT BEND RESTRICTORS</b>			
8.918-292.0	2'	5000	Black
8.918-294.0	3'	5000	Black
8.918-296.0	4'	5000	Black
8.918-298.0	5'	5000	Black
8.918-300.0	6'	5000	Black
8.918-301.0	7'	5000	Black
8.918-302.0	8'	5000	Black
8.918-303.0	9'	5000	Black
8.918-304.0	10'	5000	Black

## FLEX LINE BYPASS / SUPPLY LINE HOSE

This industrial PVC hose looks and feels like rubber and has a black seamless inner tube. The tough abrasion resistant outer cover is polyester braid reinforced and as a burst rate of three times the rated working pressure.



- Reinforced Tough Outer Cover
- Excellent for Use as Supply Lines or Bypass

PART NO.	ID X OD	WP AT 70°F	LENGTH
<b>RED COVER, HEAVY WALL</b>			
8.901-281.0	3/8" x .634"	300	50'
8.704-762.0	3/8" x .634"	300	500'
8.901-282.0	1/2" x .792"	250	50'
8.704-764.0	1/2" x .792"	250	500'
8.901-284.0	3/4" x 1.14"	160	50'
8.704-765.0	3/4" x 1.14"	160	300'
<b>RED COVER- STANDARD WALL</b>			
9.106-578.0	1/4"	160	500'
<b>BLUE COVER, STANDARD WALL</b>			
8.704-779.0	1/4"	250	475'

**CONNECTOR HOSE**

Hose comes with solid MPT crimp fittings on both ends.

PART NO.	LENGTH	PSI
<b>3/8" ULTIMA - 1-WIRE WITHOUT BEND RESTRICTORS</b>		
8.918-333.0	12'	4000
8.918-334.0	13'	4000
8.918-338.0	15'	4000
8.918-340.0	16'	4000
8.918-342.0	17'	4000
8.918-344.0	18'	4000
8.918-348.0	20'	4000
<b>3/8" ULTIMA - 1-WIRE WITH BEND RESTRICTORS ONE END</b>		
8.919-123.0	12'	4000
8.918-335.0	13'	4000
8.918-339.0	15'	4000
8.918-349.0	20'	4000
<b>1/4" BLUE - 1-WIRE WITHOUT BEND RESTRICTORS</b>		
8.918-389.0	13'	3000
8.918-391.0	14'	3000
8.918-393.0	15'	3000
8.918-395.0	16'	3000
8.918-397.0	17'	3000
8.918-399.0	18'	3000
8.918-401.0	19'	3000
8.918-403.0	20'	3000
8.918-409.0	23'	3000
8.918-411.0	24'	3000
8.918-413.0	25'	3000

PART NO.	LENGTH	PSI
<b>3/8" BLUE - 1-WIRE WITHOUT BEND RESTRICTORS</b>		
8.918-360.0	12'	3000
8.918-366.0	15'	3000
8.919-124.0	16'	3000
8.918-369.0	17'	3000
8.918-371.0	18'	3000
8.918-375.0	20'	3000
<b>3/8" BLUE - 1-WIRE WITH BEND RESTRICTORS ONE END</b>		
8.918-367.0	15'	3000
8.918-368.0	16'	3000
8.918-372.0	18'	3000
8.918-376.0	20'	3000
<b>1/4" BLUE - 1-WIRE WITH BEND RESTRICTORS ONE END</b>		
8.918-388.0	12'	3000
8.918-390.0	13'	3000
8.918-392.0	14'	3000
8.918-404.0	20'	3000

**SEWER HOSE**

Super Flexible Sewer Line Hose. Hose and couplings have small outside diameter, allowing hose and nozzles to fit through sewer line. Sewer line has Super Tough polyether cover over ultra-flexible nylon tube. 1/8" sewer nozzle and hose will operate through many 1-1/2" lines.

- Temperature: 160°F
- Nylon Tube
- 1.5 GPM Optimum Flow 1/8"  
2.5 GPM Optimum Flow 1/4"
- Ideal for cleaning lateral lines, drains & tanks
- Thermoplastic Polyurethane black cover that is oil, weather, ozone, and abrasion resistant
- Nozzles Not Included



PART NO.	DESCRIPTION
<b>1/8" HOSE - 4800 PSI, 1/4" INLET, 1/8" OUTLET</b>	
8.705-601.0	1/8" x 25'
8.705-602.0	1/8" x 50'
8.705-603.0	1/8" x 100'
<b>1/4" HOSE - 2600 PSI, 1/4" INLET, 1/4" OUTLET</b>	
8.705-607.0	1/4" x 50'
8.705-608.0	1/4" x 100'
<b>1/4" HOSE - 4400 PSI, 1/4" INLET, 1/4" OUTLET</b>	
8.705-610.0	1/4" x 50'
8.705-611.0	1/4" x 100'
8.705-613.0	1/4" x 200'



## Q.C. SOCKETS & PLUGS - LEGACY - **BRASS & STEEL**



Brass Couplers, designed for 4000 PSI and extended durability. Affordable and rugged all in one.



- PSI Max: 4000
- Precision Brass Design
- Stainless-Steel Band for Increased Durability (Except 1/2")
- Unrestricted Free-Flow

PART NO.	DESCRIPTION
9.802-164.0	1/4" FPT Brass Socket
9.802-166.0	3/8" FPT Brass Socket
9.802-165.0	1/4" MPT Brass Socket
9.802-169.0	3/8" MPT Brass Socket

Steel Nipples, hardened steel combined with zinc yellow chromate plating holds up to the harshest environments.



- PSI Max: 4000
- Zinc-Plated
- Hardened Steel

PART NO.	DESCRIPTION
8.707-136.0	1/4" FPT Steel Plug
9.802-170.0	3/8" FPT Steel Plug
8.707-165.0	1/2" FPT Steel Plug
8.707-139.0	1/4" MPT Steel Plug
9.802-171.0	3/8" MPT Steel Plug
8.707-164.0	1/2" MPT Steel Plug

## Q.C. SOCKETS & PLUGS - LEGACY - **STAINLESS-STEEL**



- PSI: 6000
- 303 Stainless-Steel
- Chemical-Resistant

PART NO.	DESCRIPTION
8.707-110.0	1/4" MPT Stainless-steel Socket
8.707-135.0	3/8" MPT Stainless-steel Socket
8.707-167.0	1/2" MPT Brass Socket
8.707-140.0	1/4" MPT Stainless-steel Plug
8.707-152.0	3/8" MPT Stainless-steel Plug
8.707-103.0	1/4" FPT Stainless-steel Socket
8.707-125.0	3/8" FPT Stainless-steel Socket
8.707-166.0	1/2" FPT Brass Socket
8.707-138.0	1/4" FPT Stainless-steel Plug
8.707-144.0	3/8" FPT Stainless-steel Plug

## O-RINGS

O-Rings for Legacy, AP, Hansen, Foster, Parker and quick-coupler brands.



- EPDM to 280°F
- Buna to 210°F
- Viton to 300°F

PART NO.	QC SIZE	BULK PART NO.*
<b>EPDM QC</b>		
8.701-981.0	1/8"	
9.802-098.0	1/4"	9.114-431.0
9.802-102.0	3/8"	9.114-432.0
<b>BUNA QC</b>		
8.702-015.0	1/4"	9.114-433.0
8.702-017.0	3/8"	9.114-434.0
8.702-021.0	1/2"	
<b>VITON QC</b>		
8.702-084.0	1/4"	9.114-435.0
8.702-088.0	3/8"	9.114-436.0
8.702-090.0	1/2"	

\*Pack of 1000

## Q.C. SOCKETS & PLUGS - FOSTER



- Precision Performance
- Unrestricted Bore for Free Flow
- Resists Plug Deformation When Pressure Spikes Occur and Withstands Pump Pulse



PART NO.	DESCRIPTION	TYPE
<b>SOCKETS</b>		
8.756-030.0	1/4" Male	Brass
8.756-031.0	1/4" Female	Brass
8.756-032.0	3/8" Male	Brass
8.756-033.0	3/8" Female	Brass
8.756-034.0	1/2" Female	Brass
<b>PLUGS</b>		
8.756-035.0	1/4" Male	Steel
8.756-036.0	1/4" Female	Steel
8.756-037.0	3/8" Male	Steel
8.756-038.0	3/8" Female	Steel
8.756-039.0	3/8" Male	Stainless-steel
8.756-040.0	3/8" Female	Stainless-steel
8.756-041.0	1/2" Male	Steel
8.756-042.0	1/2" Female	Steel



**Q.C. SOCKETS & PLUGS - SNAPTITE SERIES**

SnapTite Quick Sockets and Plugs are precision-built for extreme high pressure.

- PSI Max: 11,000
- Temperature: -40°F to 205°F
- Zinc Chromate



PART NO.	DESCRIPTION	TYPE
<b>SOCKET</b>		
8.707-115.0	1/4" FPT	Zinc Chromate
8.707-116.0	1/4" MPT	Zinc Chromate
9.802-167.0	3/8" FPT	Zinc Chromate
<b>PLUG</b>		
8.707-117.0	1/4" FPT	Zinc Chromate
8.707-121.0	1/4" MPT	Zinc Chromate
9.802-168.0	3/8" FPT	Zinc Chromate
8.707-120.0	3/8" MPT	Zinc Chromate
<b>SEAL, U-PACK</b>		
9.804-043.0	1/4"	Zinc Chromate
8.706-712.0	3/8"	Zinc Chromate

**Q.C. SOCKETS & PLUGS - ST SERIES**

SERIES	STEEL PLUG	BRASS PLUG	STAINLESS-STEEL
	PSI	PSI	PSI
1/8"	2600	2500	4200
1/4"	5500	5200	6700
3/8"	3500	2700	6300
1/2"	2700	2200	3000
3/4"	1700	1700	1700

PART NO.	DESCRIPTION	TYPE
<b>SOCKETS</b>		
8.709-436.0	1/8" MPT	Brass
8.709-463.0	3/4" MPT	Brass
8.709-462.0	3/4" FPT	Brass
8.709-566.0	3/8" MPT	Stainless-steel
8.709-564.0	3/8" FPT	Stainless-steel
8.709-457.0	1/2" FPT	Stainless-steel
<b>PLUGS</b>		
8.709-478.0	1/8" MPT	Steel, Zinc-plated
8.709-479.0	1/8" FPT	Steel, Zinc-plated
8.709-502.0	3/4" MPT	Steel, Zinc-plated
8.709-509.0	3/4" FPT	Steel, Zinc-plated
8.709-486.0	1/4" MPT	Hardened Stainless-steel
8.709-488.0	1/4" FPT	Hardened Stainless-steel
8.709-480.0	1/2" MPT	Hardened Stainless-steel
8.709-481.0	1/2" FPT	Hardened Stainless-steel



### Q.C. SOCKETS & PLUGS - M22 - TWIST SEAL

Allows U.S. standard hose to connect to 22 mm European fittings.



- PSI Max: 4000
- GPM: 7.8
- Temperature Max: 302°F
- Internal O-Ring Seal
- Machined-brass Body
- High-Impact Plastic Knob
- Not Threaded

PART NO.	DESCRIPTION	TYPE
8.709-522.0	1/4" FPT	Machined-brass Body
8.709-530.0	3/8" FPT	Machined-brass Body
9.802-173.0	1/4" MPT	Machined-brass Body
8.709-526.0	3/8" MPT	Machined-brass Body

Plugs are made of heavy-duty machined-brass for a safe and leak-free connection.



O-Rings, Viton

PART NO.	DESCRIPTION	TYPE
8.709-540.0	1/4" FPT	Machined-brass Body
8.709-546.0	3/8" FPT	Machined-brass Body
8.709-536.0	1/4" MPT	Machined-brass Body
8.707-185.0	3/8" MPT	Machined-brass Body

### Q.C. SOCKETS & PLUGS - EXTENDED TWIST SEAL



- PSI: 3600
- GPM: 11
- Temperature: 300°F
- Double O-Ring Seal
- Machined-Brass Body
- High-Impact Plastic Knob

PART NO.	DESCRIPTION	PSI MAX
8.709-535.0	1/4" FPT x M22, Female, Coupler	3600
8.709-555.0	1/4" FPT x M22, Male, Plug	3600

### Q.C. SOCKETS & PLUGS - M22 - TWIST SEAL

Couples U.S. standard pipe threads to 22 mm European fittings found on imported pressure washers.



Sockets

- PSI Max: 4000, GPM: 7.8
- Temperature Max: 302°F
- 3.9 to 4.2 Oz. Weight
- Internal O-ring with back ring seal assures no-leak operation
- Oversized High-Impact Plastic Knob
- Machined-Brass Body

PART NO.	DESCRIPTION	TYPE
8.709-524.0	1/4" FPT	Machined-brass Body
8.709-531.0	3/8" FPT	Machined-brass Body
8.709-534.0	1/2" FPT	Machined-brass Body
8.709-521.0	1/4" MPT	Machined-brass Body
8.709-528.0	3/8" MPT	Machined-brass Body
8.709-533.0	1/2" MPT	Machined-brass Body



Plugs

PART NO.	DESCRIPTION	TYPE
8.709-548.0	3/8" FPT	Machined-brass Body
8.709-553.0	1/2" FPT	Machined-brass Body
8.709-539.0	1/4" MPT	Machined-brass Body
8.709-551.0	1/2" MPT	Machined-brass Body

### Q.C. SOCKETS & PLUGS- M22 - QUICK DISCONNECT



Part # 8.709-554.0

- PSI: 4000
- Temperature: 175°F
- EPDM O-Rings
- Machined-brass Body

PART NO.	DESCRIPTION
8.709-554.0	3/8" QC Coupler X M22 M
8.709-601.0	3/8" Plug X M22 F
9.114-604.0	3/8" QC Coupler X M22 F



O-Rings - M22, Viton

PART NO.	DESCRIPTION
8.704-036.0	O-rings, M22 Viton
8.704-037.0	Back Ring, 2.4 x 9.3
8.756-782.0	O-rings (EPDM)

**Q.C. SOCKETS & PLUGS - DOUBLE SHUT-OFF**



8.709-580.0



8.709-556.0

- Quick disconnect without drips and leaks
- Indispensable for in-plant multiple station systems
- Machined-construction brass, zinc-plated steel or stainless steel

PART NO.	DESCRIPTION	TYPE	PSI MAX
<b>SOCKETS</b>			
8.709-556.0	1/8" FPT	Brass	3000
8.756-043.0	1/4" FPT	Brass	2700
8.709-559.0	3/8" FPT	Brass	2200
8.709-560.0	1/2" FPT	Brass	2250
8.709-561.0	1/2" FPT	Stainless-steel	4250
8.709-562.0	3/4" FPT	Brass	2000
<b>PLUGS</b>			
8.709-580.0	1/8" FPT	Brass	3000
8.709-583.0	1/4" FPT	Brass	2200
8.756-044.0	1/4" FPT	Brass	2700
8.709-584.0	1/2" FPT	Brass	2250
8.709-582.0	3/8" FPT	Steel, Zinc	4000

**Q.C. SOCKETS & PLUGS - FOSTER DOUBLE SHUT-OFF**



PART NO.	DESCRIPTION	TYPE
<b>SOCKET</b>		
8.756-043.0	1/4" FPT, Double Shut Off	Brass
<b>PLUG</b>		
8.756-044.0	1/4" FPT, Double Shut Off	Brass



Replacement O-Rings

- Nitrile Up to 210°F
- Use Viton for 230°F and Above

PART NO.	DESCRIPTION	TYPE	MAX TEMP
8.701-994.0	1/8" O-ring	Nitrile	Up To 210°F
8.702-015.0	1/4" O-ring	Nitrile	Up To 210°F
8.702-017.0	3/8" O-ring	Nitrile	Up To 210°F
8.702-021.0	1/2" O-ring	Nitrile	Up To 210°F
8.702-084.0	1/4" O-ring	Viton	230°F +
8.702-088.0	3/8" O-ring	Viton	230°F +
8.702-090.0	1/2" O-ring	Viton	230°F +
8.702-023.0	3/32" O-ring	Nitrile*	230°F +

\* For Kit 1

**Q.C. SOCKETS & PLUGS - A+ BRASS**

Designated for 4000 PSI and extended durability. EPDM O-rings as standard. Affordable and rugged all in one.



PART NO.	DESCRIPTION	PSI
8.750-695.0	1/4" Socket FPT	4000
8.750-696.0	1/4" Socket MPT	4000
8.750-697.0	3/8" Socket FPT	4000
8.750-698.0	3/8" Socket MPT	4000

**SWIVELS - 90°**

Excellent for car wash booms and hose reels. Remarkable value, comparable to best swivels made.



- PSI: 4000
- Temperature: 225°F
- Forged-Brass Body
- Nitrile O-Ring

PART NO.	DESCRIPTION	PSI MAX
8.712-460.0	3/8" M x 3/8" F	4000
8.712-461.0	3/8" F x 3/8" F	4000
8.712-462.0	1/2" M x 1/2" F	4000
8.712-463.0	1/2" F x 1/2" F	4000
8.712-464.0	1/2" M x 3/8" F	4000
8.712-469.0	3/8" F x 3/4" M w 3/8" Inside thread	4000
8.900-855.0	Repair Kit	4000

**SWIVELS - RIGHT ANGLE**



8.712-449.0

- PSI Max: 3000 (Brass)
- PSI Max: 5000 (Stainless-Steel)
- Temperature: 300°F
- 360° Swivel Rotation



8.712-448.0

PART NO.	DESCRIPTION	TYPE
8.712-448.0	3/8" Swivel	Stainless-steel
8.712-450.0	3/8" Swivel	Brass
8.712-449.0	1/2" Swivel	Brass
8.700-287.0	3/8" Repair Kit for 8.712-448.0, 8.712-450.0	
8.700-285.0	1/2" Repair Kit for 8.712-449.0	



## SWIVELS - STAINLESS-STEEL, HIGH-PRESSURE

Perfect for Hose to Trigger Gun Swivel connection



- GPM Max: 15
- MAX PSI: 5000
- Temperature: 250° F
- Viton Seals

PART NO.	DESCRIPTION	PSI
9.113-294.0	3/8 MPT X FPT	5000



## SWIVELS - STAINLESS-STEEL BALL BEARING



- PSI Max: 3500
- Temperature: 180°F
- Hardened, Stainless-Steel Body
- Nitrile Buna Seals
- M x F NPT Thread
- Ball-bearing design ensures free swivel action under pressure
- Suitable for extended-wear applications

PART NO.	DESCRIPTION	GPM
8.712-457.0	1/4" Stainless-steel	6.8
8.712-458.0	3/8" Stainless-steel	10.6
8.712-459.0	1/2" Stainless-steel	27.0
8.700-459.0	Repair Kit for 8.712-458.0	
8.700-460.0	Repair Kit for 8.712-457.0	
8.700-461.0	Repair Kit for 8.712-459.0	

## SWIVELS - STAINLESS-STEEL, HIGH-PRESSURE AND ECONOMY BRASS



- GPM Max:  
10.5 (Stainless-Steel)  
7.8 (Brass)
- Temperature:  
320°F (Stainless-Steel)  
195°F (Brass)
- Highly Resistant to Harsh Chemicals
- "Live" Swivel at Full Pressure
- Weight: 6 oz..

PART NO.	DESCRIPTION	PSI
8.712-456.0	1/4" M x F, Swivel - SS	5600
8.712-455.0	3/8" M x F, Swivel - SS	5600
8.712-443.0	3/8" M x F, Swivel - Brass	3600
8.704-096.0	Repair Kit for 8.712-456.0, 8.712-455.0	

## SWIVELS - STAINLESS-STEEL



- PSI: 4000
- Temperature: 200°F
- All Stainless Construction
- Teflon® Swivel Ring
- Rebuildable
- 3/8" In and Out

PART NO.	DESCRIPTION
8.712-446.0	3/8" MPT x FPT
8.712-447.0	3/8" FPT x FPT
8.900-764.0	Seal Kit

## SWIVELS - GUN - MOSMATIC

Made of corrosion-resistant material and stainless-steel, self-lubricated bearings, the new gun swivel offers highest-quality Swiss-made craftsmanship.



- PSI: 4000
- Temperature: 250°F
- GPM: 30

PART NO.	DESCRIPTION
8.712-467.0	1/4" NPTF, Gun Swivel
8.712-466.0	3/8" NPTF, Gun Swivel



## SWIVELS - BALL BEARING

Swivels freely even at maximum pressure level noted below.



8.712-438.0

8.712-479.0

- Brass and Stainless-steel Materials
- Inline & 90 Degree Options

PART NO.	DESCRIPTION	PSI MAX
<b>INLINE SWIVELS</b>		
8.712-438.0	1/4" MPT x FPT	2000
8.712-439.0	1/4" MPT x FPT	3500
8.712-440.0	3/8" MPT x FPT	2000
8.712-441.0	3/8" MPT x FPT	3500
<b>90° SWIVELS</b>		
8.712-479.0	1/4" 90°	3500
8.700-263.0	Rebuild Kit	

**SWIVELS - A+ LONG BODY STYLE**



- PSI: 3000
- Brass Housing
- Stainless-Steel Flow-Through Bolt
- Close-tolerance fit ensures leakproof seal
- Teflon® Ring Provides Free Swivel

PART NO.	DESCRIPTION	TYPE
8.904-551.0	3/8" MPT x FPT*	Brass
8.904-552.0	3/8" FPT x FPT*	Brass
8.900-764.0	Seal Kit	

\* Long Body Style

**ADAPTERS - BRASS**



- FPT X MPT

PART NO.	DESCRIPTION	TYPE
8.705-186.0	1/8" x 1/8"	Brass
9.803-054.0	1/4" x 1/8"	Brass
8.705-188.0	1/4" x 1/4"	Brass
8.705-185.0	3/8" x 1/8"	Brass
9.804-007.0	3/8" x 1/4"	Brass
8.705-190.0	3/8" x 3/8"	Brass
8.705-192.0	1/2" x 1/4"	Brass
8.705-191.0	1/2" x 3/8"	Brass
9.802-148.0	1/2" x 1/2"	Brass
8.705-194.0	3/4" x 1/2"	Brass
8.705-195.0	3/4" x 3/4"	Brass

**BUSHINGS - BRASS**



- FPT X MPT

PART NO.	DESCRIPTION	TYPE
9.803-564.0	1/4" x 1/8"	Brass
8.705-129.0	3/8" x 1/4"	Brass
9.804-015.0	3/8" x 1/8"	Brass
9.802-135.0	1/2" x 1/4"	Brass
8.705-132.0	1/2" x 3/8"	Brass
8.705-133.0	3/4" x 3/8"	Brass
9.802-136.0	3/4" x 1/2"	Brass

**HEX COUPLINGS - BRASS**



PART NO.	DESCRIPTION	TYPE
8.705-150.0	1/8" F	Brass
8.705-151.0	1/4" F	Brass
8.705-152.0	3/8" F	Brass
8.705-153.0	1/2" F	Brass
8.705-154.0	3/4" F	Brass

**HEX COUPLINGS - REDUCING - BRASS**



PART NO.	DESCRIPTION	TYPE
8.705-155.0	1/4" x 1/8" F	Brass
8.705-156.0	3/8" x 1/4" F	Brass
8.705-157.0	1/2" x 1/4" F	Brass
8.705-158.0	1/2" x 3/8" F	Brass
8.705-159.0	3/4" x 1/2" F	Brass

**HEX NIPPLES - DOUBLE - BRASS**



PART NO.	DESCRIPTION	TYPE
8.705-224.0	1/8" x 1/8" M	Brass
9.802-108.0	1/4" x 1/4" M	Brass
8.705-228.0	3/8" x 3/8" M	Brass
9.803-989.0	1/2" x 1/2" M	Brass
8.705-233.0	3/4" x 3/4" M	Brass
8.705-234.0	1" x 1" M	Brass

**HEX REDUCING NIPPLES - BRASS**



PART NO.	DESCRIPTION	TYPE
8.630-575.0	1/4" x 1/8" M	Brass
8.705-223.0	3/8" x 1/8" M	Brass
8.705-227.0	3/8" x 1/4" M	Brass
8.705-229.0	1/2" x 1/4" M	Brass
9.803-276.0	1/2" x 3/8" M	Brass
9.803-556.0	3/4" x 1/2" M	Brass

## NIPPLES - BRASS - OPEN & CLOSE

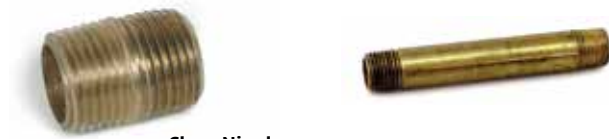

Close Nipple

PART NO.	DESCRIPTION	TYPE
8.705-201.0	1/8" Close	Brass
8.705-204.0	1/4" Close	Brass
8.705-211.0	3/8" Close	Brass
9.802-109.0	1/2" Close	Brass
8.705-220.0	3/4" Close	Brass
8.705-202.0	1/8" x 1-1/2"	Brass
8.705-203.0	1/8" x 2-1/2"	Brass
8.705-205.0	1/4" x 1-1/2"	Brass
8.705-206.0	1/4" x 2"	Brass
8.705-207.0	1/4" x 2-1/2"	Brass
8.705-212.0	3/8" x 1-1/2"	Brass
8.705-213.0	3/8" x 2-1/2"	Brass
8.705-214.0	3/8" x 3"	Brass
8.705-217.0	1/2" x 1-1/2"	Brass
8.705-218.0	1/2" x 3"	Brass
8.705-221.0	3/4" x 2"	Brass
8.705-222.0	3/4" x 3"	Brass

## SWIVELS - JIC



9.802-151.0

PART NO.	DESCRIPTION	TYPE
9.802-153.0	1/4" Barb x 1/4" JIC FPT	Brass
9.802-151.0	1/2" Barb x 1/2" JIC FPT	Brass
9.802-152.0	3/4" Barb x 3/4" JIC FPT	Brass
9.802-048.0	1/2" JIC FPT x 3/8" MPT	Steel
8.706-315.0	1/2" JIC FPT x 1/2" MPT	Steel

## NIPPLES - JIC X-PIPE



PART NO.	DESCRIPTION
8.706-265.0	1/2" JIC x 1/4" FPT
9.802-037.0	1/2" JIC x 3/8" FPT
9.802-036.0	1/2" JIC x 3/8" MPT
9.802-038.0	1/2" JIC x 1/2" MPT

## ELBOWS - 90° - BRASS



PART NO.	DESCRIPTION	TYPE
8.705-160.0	1/8" FPT	Brass
8.705-161.0	1/4" FPT	Brass
9.802-113.0	3/8" FPT	Brass
9.803-265.0	1/2" FPT	Brass
8.705-164.0	3/4" FPT	Brass
8.705-169.0	1/4" x 1/4" MPT	Brass
8.705-171.0	3/8" x 3/8" MPT	Brass
8.705-173.0	1/2" x 1/2" MPT	Brass
9.802-129.0	1/2" JIC x 3/8" MPT	Brass
9.802-131.0	1/2" JIC x 1/2" MPT	Brass

### REDUCING ELBOWS

8.705-165.0	1/4" FPT x 1/8" FPT	Brass
8.705-166.0	3/8" FPT x 1/4" FPT	Brass
8.705-168.0	1/4" x 1/8" MPT	Brass
8.705-167.0	3/8" x 1/8" MPT	Brass
8.705-170.0	3/8" x 1/4" MPT	Brass
8.705-172.0	1/2" x 3/8" MPT	Brass

## ELBOWS - STREET-BRASS



PART NO.	DESCRIPTION	TYPE
<b>90° STREET ELBOWS</b>		
8.705-174.0	1/8" M x F	Brass
9.803-839.0	1/4" M x F	Brass
9.802-114.0	3/8" M x F	Brass
9.802-115.0	1/2" M x F	Brass
9.803-555.0	3/4" M x F	Brass
<b>45° STREET ELBOWS</b>		
8.705-180.0	1/8" M x F	Brass
8.705-181.0	1/4" M x F	Brass
8.705-182.0	3/8" M x F	Brass
8.705-183.0	1/2" M x F	Brass
8.705-184.0	3/4" M x F	Brass



**TEES - FPT - FORGED-BRASS**



PART NO.	DESCRIPTION	TYPE
8.705-246.0	1/8" F	Brass
8.705-247.0	1/4" F	Brass
8.705-248.0	3/8" F	Brass
9.802-117.0	1/2" F	Brass
8.705-251.0	3/4" F	Brass

**TEES - BRANCH-BRASS**



■ FPT x FPT x MPT Pipe Run

PART NO.	DESCRIPTION	TYPE
9.802-120.0	1/4"	Brass
8.705-254.0	3/8"	Brass
8.705-255.0	1/2"	Brass

**TEES - STREET-BRASS**



■ FPT x FPT x MPT Pipe Run

PART NO.	DESCRIPTION	TYPE
9.802-121.0	1/4"	Brass
8.705-257.0	3/8"	Brass
9.802-122.0	1/2"	Brass
8.705-259.0	3/4"	Brass

**CROSSES - FPT - BRASS EXTRUDED**



PART NO.	DESCRIPTION	TYPE
8.705-196.0	1/4"	Brass
8.705-197.0	3/8"	Brass
8.705-198.0	1/2"	Brass
8.705-199.0	3/4"	Brass

**NIPPLES - JIC - BRASS**



9.802-128.0



8.706-894.0

PART NO.	DESCRIPTION	TYPE
8.706-872.0	1/2" JIC x 1/4" MPT	Brass
9.802-127.0	1/2" JIC x 3/8" MPT	Brass
9.802-128.0	1/2" JIC x 1/2" MPT	Brass
8.706-877.0	1/2" JIC x 3/4" MPT	Brass
8.706-894.0	1/2" JIC x 1/2" FPT	Brass
8.706-895.0	1/2" JIC x 3/8" FPT	Brass
8.706-896.0	1/2" JIC x 1/4" FPT	Brass
8.706-897.0	1/2" JIC x 3/4" FPT	Brass
8.706-899.0	3/4" JIC x 3/4" Pipe MPT	Brass
8.706-971.0	1/2" JIC x 3/4" GHF	Brass

**BARBS - PUSH-N-LOCK**



Normally requires no clamps



Barb x Barb

PART NO.	DESCRIPTION	TYPE
<b>BARB X MPT</b>		
8.705-069.0	1/4" x 1/8"	Brass
8.705-070.0	1/4" x 1/4"	Brass
8.705-071.0	1/4" x 3/8"	Brass
8.705-072.0	3/8" x 1/8"	Brass
8.705-073.0	3/8" x 1/4"	Brass
8.705-074.0	3/8" x 3/8"	Brass
8.705-075.0	3/8" x 1/2"	Brass
8.705-076.0	3/8" x 3/4"	Brass
8.705-077.0	1/2" x 1/4"	Brass
9.802-156.0	1/2" x 3/8"	Brass
8.705-079.0	1/2" x 1/2"	Brass
8.705-080.0	1/2" x 3/4"	Brass
8.705-081.0	5/8" x 3/8"	Brass
8.705-082.0	5/8" x 1/2"	Brass
8.705-083.0	5/8" x 3/4"	Brass
8.705-084.0	3/4" x 1/2"	Brass
8.705-085.0	3/4" x 3/4"	Brass
<b>BARB X BARB</b>		
8.705-064.0	1/4" x 1/4"	Brass
8.705-065.0	3/8" x 3/8"	Brass
8.705-066.0	1/2" x 1/2"	Brass
8.705-067.0	5/8" x 5/8"	Brass
8.705-068.0	3/4" x 3/4"	Brass



## HOSE BARBS - BRASS CHECK BARBS



- 1/4" MPT x 1/4" Barb
- Brass Body
- Buna or Viton Check Ball

PART NO.	DESCRIPTION	TYPE
8.904-389.0	Check Hose Barb - Viton	Brass Body
8.904-390.0	Check Hose Barb - Buna	Brass Body

## HOSE BARBS - SWIVEL - LOW PRESSURE

Swivels easily at low pressure to eliminate twists and tangles in chemical or water lines.



- PSI Max: 300
- Temperature: 210°F
- Brass MPT base with steel hose barb

PART NO.	DESCRIPTION	TYPE
8.705-050.0	1/4" x 1/4"	Brass MPT, Steel Hose Barb
8.705-052.0	3/8" x 3/8"	Brass MPT, Steel Hose Barb
8.705-053.0	1/2" x 1/2"	Brass MPT, Steel Hose Barb

## HOSE BARBS - ORIFICED

Inexpensive way to create suction on inlet side of pump



- 3/8" MPT x 5/8" Barb
- Used in-line from float tank to pump
- One-Piece, Machined-Brass
- Standard orifice 5/32" - drill up to 3/8" to fit your need

PART NO.	DESCRIPTION	TYPE
8.705-093.0	Orificed Hose Barb	Machined Brass

## DRAIN COCKS



PART NO.	DESCRIPTION
8.705-060.0	1/4" Fuel Drain with Tee Handle
8.705-061.0	1/4" Fuel Drain with Barb and Tee Handle

## HOSE BARBS - BRASS



90° Barb x MPT

- 90° Barb x MPT, Barb x MPT, & Barb x FPT



Barb x MPT

PART NO.	DESCRIPTION	TYPE
<b>90° BARB X MPT</b>		
9.802-142.0	1/4" x 1/8"	Brass
9.802-143.0	1/4" x 1/4"	Brass
8.705-118.0	3/8" x 1/4"	Brass
8.705-119.0	3/8" x 3/8"	Brass
8.705-120.0	3/8" x 1/2"	Brass
8.705-121.0	1/2" x 1/4"	Brass
8.705-122.0	1/2" x 3/8"	Brass
8.705-123.0	1/2" x 1/2"	Brass
8.705-125.0	5/8" x 3/8"	Brass
8.705-126.0	5/8" x 1/2"	Brass
<b>BARB X MPT</b>		
8.705-097.0	1/8" x 1/4"	Brass
9.802-137.0	1/4" x 1/8"	Brass
9.802-138.0	1/4" x 1/4"	Brass
8.705-102.0	1/4" x 3/8"	Brass
8.705-108.0	1/4" x 1/2"	Brass
8.705-098.0	3/8" x 1/8"	Brass
8.705-104.0	3/8" x 1/4"	Brass
8.705-105.0	3/8" x 3/8"	Brass
8.705-103.0	3/8" x 1/2"	Brass
8.705-100.0	3/8" x 3/4"	Brass
8.705-110.0	1/2" x 1/4"	Brass
8.705-106.0	1/2" x 3/8"	Brass
8.705-109.0	1/2" x 1/2"	Brass
8.705-111.0	1/2" x 3/4"	Brass
8.705-107.0	5/8" x 3/8"	Brass
9.802-140.0	5/8" x 1/2"	Brass
8.705-113.0	5/8" x 3/4"	Brass
8.705-114.0	3/4" x 1/2"	Brass
8.705-115.0	3/4" x 3/4"	Brass
<b>BARB X FPT</b>		
8.706-949.0	1/4" x 1/4"	Brass

**PLUGS - HEX HEAD**



PART NO.	DESCRIPTION
8.705-236.0	1/8"
8.705-238.0	1/4"
8.705-240.0	3/8"
9.803-673.0	1/2"
8.705-244.0	3/4"

**PLUGS - ALLEN HEAD**



PART NO.	DESCRIPTION
9.803-051.0	1/8"
9.802-124.0	1/4"
8.705-241.0	3/8"
8.705-243.0	1/2"

**LOCKNUT FITTINGS - HEX-HEAD PLUGS**



PART NO.	DESCRIPTION
8.705-041.0	1/8"
8.705-042.0	1/4"
8.705-043.0	3/8"
8.705-044.0	1/2"
8.705-045.0	3/4"

**GARDEN HOSE FITTINGS**



8.901-292.0      8.705-034.0

- MGH = Male Garden Hose
- FGH = Female Garden Hose
- Heavy-Duty, Machined-brass Fittings



8.709-460.0      9.804-016.0      9.802-145.0      8.705-087.0

PART NO.	DESCRIPTION
----------	-------------

**SWIVEL FITTINGS - 3/4" FGH**

8.705-032.0	1/4" MPT
8.901-292.0	3/8" MPT
8.901-291.0	1/2" MPT
8.705-033.0	1/2" FPT (S-1)
9.802-146.0	3/4" FGH Swivel with 1/2" MPT Strainer
8.705-034.0	3/4" FPT (S-2)
8.705-035.0	3/4" FGH (S-3)
8.705-008.0	1/2" Barb
8.705-009.0	5/8" Barb
8.705-010.0	3/4" Barb

**GARDEN HOSE QUICK COUPLERS**

8.709-460.0	Female Hose Coupler
8.709-508.0	Male Hose Plug

**GARDEN HOSE ACCESSORIES**

8.705-016.0	Garden Hose Washer
9.804-016.0	Filter Screen Washer (30-mesh)

**SOLID FITTINGS**

8.705-024.0	3/4" MGH x 3/8" MPT
9.802-145.0	3/4" MGH x 1/2" MPT
8.705-026.0	3/4" MGH x 3/4" MPT
8.705-019.0	3/4" FGH x 1/2" FPT
8.705-020.0	3/4" FGH x 3/4" FPT
8.705-022.0	3/4" FGH x 1/2" MPT
8.705-023.0	3/4" FGH x 3/4" MPT
8.705-018.0	3/4" FGH x 3/4" FGH (Stainless-steel)

**HOSE BARB FITTINGS**

8.705-086.0	3/8" Barb x 3/4" MGH
8.705-087.0	1/2" Barb x 3/4" MGH
8.705-088.0	5/8" Barb x 3/4" MGH
8.705-089.0	3/4" Barb x 3/4" MGH
8.705-091.0	3/8" Barb x 3/4" FGH
8.705-092.0	1/2" Barb x 3/4" FGH
8.705-094.0	5/8" Barb x 3/4" FGH
8.705-095.0	3/4" Barb x 3/4" FGH

## HOSE CLAMPS

WARNING: LOW-PRESSURE USE ONLY!



- Not for Use on Pressure Washer Discharge Hose
- Stainless-Steel Band and Housing
- Screw Clamp - Gear Tensions



- Nylon "Speedi-Clamp" Tightens with a Snap
- Releases with a Twist
- Pack of 50

PART NO.	BAND	OD	MIN	MAX
<b>SCREW CLAMPS</b>				
9.802-200.0	4 mm	5/16"	.25	.63
8.710-456.0	5 mm	5/16"	.38	.88
8.710-457.0	10 mm	5/16"	.50	1.06
8.710-458.0	H8	1/2"	.44	.91
8.710-459.0	H10	1/2"	.56	1.06
8.710-460.0	H12	1/2"	.69	1.25
8.710-461.0	H16	1/2"	.7	1.50
8.710-464.0	H32	1/2"	1.56	2.50
6.390-126.0	Red Spring Clamp		.466	.54
8.709-116.0	Green Spring Clamp		.40	.48
<b>SPEEDI-CLAMPS - PACKS OF 50</b>				
8.904-167.0	1/4" ID Speedi-Clamp			
8.904-168.0	3/8" ID Speedi-Clamp			

## ADAPTERS - HIGH PSI - STEEL



- MPT x FPT

PART NO.	DESCRIPTION	PSI	TYPE
8.705-356.0	1/4" x 1/4"	6000	Steel
8.705-357.0	1/4" x 3/8"	6000	Steel
9.804-553.0	3/8" x 3/8"	6000	Steel
8.706-302.0	3/8" x 1/2"	6000	Steel
8.705-360.0	1/2" x 1/2"	6000	Steel
8.705-361.0	1/2" x 3/4"	6000	Steel
8.705-362.0	3/4" x 3/4"	6000	Steel



## COUPLINGS - HEX - HIGH PSI - STEEL

- Up to 6000 PSI Working Pressure (18,000 PSI Burst)
- Attractive Zinc-Plated Protective Coating
- U.S. Standard Taper Pipe Threads

## COUPLINGS - HEX - HEAVY WALL STEEL



- FPT x FPT

PART NO.	DESCRIPTION	PSI
<b>HEX COUPLINGS</b>		
8.705-364.0 	1/4" x 1/4"	6000
8.705-366.0 	3/8" x 3/8"	6000
8.706-141.0	1/2" x 1/2"	5000
8.705-371.0	3/4" x 3/4"	5000
<b>REDUCING COUPLINGS</b>		
8.705-365.0	3/8" x 1/4"	6000
8.705-367.0	1/2" x 3/8"	5000
8.705-368.0	1/2" x 1/4"	5000
8.705-370.0	3/4" x 1/2"	4000

## NIPPLES - HEX - HIGH PSI - STEEL



- MPT X MPT

PART NO.	DESCRIPTION	PSI
9.802-010.0	1/4" x 1/4"	6000
9.802-011.0	3/8" x 3/8"	6000
9.802-012.0	1/2" x 1/2"	6000
8.705-380.0	3/4" x 3/4"	6000
9.802-022.0	3/8" x 1/4"	6000
8.705-375.0	1/2" x 1/4"	6000
8.705-376.0	1/2" x 3/8"	6000
8.705-379.0	3/4" x 1/2"	6000

## ELBOWS - 45°



- FPT X FPT

PART NO.	DESCRIPTION
8.706-278.0	3/8" x 3/8", 45°
8.706-277.0	1/4" x 1/4", 45°

**ELBOWS - STREET - HIGH PSI - STEEL**



■ MPT x FPT

PART NO.	DESCRIPTION	PSI
9.802-029.0	1/4" x 1/4"	6000
9.804-080.0	1/4" x 3/8"	6000
9.802-030.0	3/8" x 3/8"	6000
8.705-384.0	3/8" x 1/2"	6000
9.803-045.0	1/2" x 1/2"	6000
8.705-386.0	1/2" x 3/4"	6000
8.705-387.0	3/4" x 3/4"	6000

**TEES - STREET TEE - HIGH PSI - STEEL**



■ FPT x FPT x MPT Pipe Run

PART NO.	DESCRIPTION	PSI
8.705-428.0	1/4"	5000
9.802-033.0	3/8"	4500
9.802-034.0	1/2"	3000
8.705-431.0	3/4"	3000

**ELBOWS - HIGH PSI - STEEL**



PART NO.	DESCRIPTION	PSI
8.706-176.0	1/4" x 1/8" FPT	4500
8.705-393.0	1/4" x 1/4" FPT	5000
8.705-394.0	1/4" x 3/8" FPT	4500
9.802-023.0	3/8" x 3/8" FPT	4500
8.705-396.0	3/8" x 1/2" FPT	3000
8.705-397.0	1/2" x 1/2" FPT	3000
8.705-398.0	1/2" x 3/4" FPT	4000
8.705-399.0	3/4" x 3/4" FPT	4000
9.802-039.0	1/2" JIC x 3/8" MPT	5000
9.802-040.0	1/2" JIC x 1/2" MPT	5000
9.802-130.0	1/2" JIC x 1/4" MPT	5000
8.706-906.0	1/2" JIC x 3/4" FPT	5000

**CROSSES - 4 CONNECTS - HIGH PSI - STEEL**



PART NO.	DESCRIPTION	PSI
8.705-418.0	1/4" FPT	5000
8.705-419.0	3/8" FPT	4500
8.705-420.0	1/2" FPT	3000
8.705-421.0	3/4" FPT	3000

**TEES - 3 CONNECTS - HIGH PSI - FORGED**



PART NO.	DESCRIPTION	PSI
8.705-412.0	1/4" FPT	5000
8.705-414.0	3/8" FPT	4500
8.706-216.0	1/2" FPT	3000
8.705-417.0	3/4" FPT	3000
8.706-213.0	1/4" MPT	5000

**REDUCING BUSHING - HIGH PSI - STEEL**



■ MPT x FPT

PART NO.	DESCRIPTION	PSI	TYPE
9.802-046.0	3/8" x 1/4"	6000	Steel
8.705-423.0	1/2" x 1/4"	6000	Steel
9.802-045.0	1/2" x 3/8"	6000	Steel
8.705-426.0	3/4" x 1/2"	6000	Steel

**HEX PIPE PLUGS - HIGH PSI - STEEL**



PART NO.	DESCRIPTION	PSI	TYPE
9.803-530.0	1/4" MPT	6000	Steel
8.705-433.0	3/8" MPT	6000	Steel
8.705-434.0	1/2" MPT	6000	Steel
8.705-435.0	3/4" MPT	6000	Steel

## GALVANIZED PIPE FITTINGS

- Pressed-Steel Fittings - external galvanized for excellent chemical resistance
- NOT recommended for high-pressure piping applications
- Ideal for supply line (city water pressure) applications working pressure rating of 125 PSI

## ELBOWS - STREET - 90° - GALVANIZED



PART NO.	DESCRIPTION
8.705-407.0	1/4" MPT x FPT
8.705-408.0	3/8" MPT x FPT
8.705-409.0	1/2" MPT x FPT
8.705-410.0	3/4" MPT x FPT

## TEES - BANDED - 3 CONNECTS - GALVANIZED



PART NO.	DESCRIPTION
8.705-456.0	1/4" FPT x FPT x FPT
8.705-458.0	3/8" FPT x FPT x FPT
8.705-459.0	1/2" FPT x FPT x FPT
8.705-461.0	3/4" FPT x FPT x FPT

## COUPLINGS - GALVANIZED



PART NO.	DESCRIPTION
8.705-436.0	1/4" FPT x FPT
8.705-437.0	3/8" FPT x FPT
8.705-438.0	1/2" FPT x FPT
8.705-439.0	3/4" FPT x FPT

## ELBOWS - 90° - GALVANIZED



PART NO.	DESCRIPTION
8.705-403.0	1/4" FPT x FPT
8.705-405.0	1/2" FPT x FPT
8.705-406.0	3/4" FPT x FPT

## NIPPLES - PIPE - MPT - HIGH PSI - ZINC





PART NO.	DESCRIPTION	PSI	TYPE
9.803-043.0	2" x 1/4"	6000	Zinc
8.705-441.0	3" x 1/4"	6000	Zinc
8.705-442.0	4" x 1/4"	6000	Zinc
8.705-443.0	2" x 3/8"	6000	Zinc
8.705-985.0	3" x 3/8"	6000	Zinc
8.705-445.0	4" x 3/8"	6000	Zinc
8.705-446.0	2" x 1/2"	6000	Zinc
9.802-014.0	3" x 1/2"	6000	Zinc
9.802-015.0	4" x 1/2"	6000	Zinc
8.705-996.0	5" x 1/2"	6000	Zinc
8.705-450.0	2" x 3/4"	6000	Zinc
8.705-451.0	3" x 3/4"	6000	Zinc
8.705-452.0	4" x 3/4"	6000	Zinc
8.705-453.0	6" x 3/4"	6000	Zinc

## FILTERS - CHEMICAL - "THE BIG ONE"

Larger, heavier, and with more filtering area than competitors' filters.



- Corrosion-resistant Plastic
- Stepped 1/4" & 3/8" Hose Barb
- Weighted to Hold onto Bottom of Tank

PART NO.	DESCRIPTION
8.709-938.0	 with Check Valve
8.709-939.0	 without Check Valve

## FILTERS - CHEMICAL - BRASS

50-mesh, stainless-steel screen. Removable mesh for easy cleaning. Heavy-duty, one-piece brass body holds the filter on the bottom of tank.



- 1/4" Hose Barb
- Stainless-Steel Check Ball

PART NO.	DESCRIPTION
9.803-672.0	with Check Valve
8.709-934.0	without Check Valve



**FILTERS - CHEMICAL - BRASS / PLASTIC**

Polypropylene and brass construction.



- 7 mm Hose Barb

PART NO.	DESCRIPTION
8.709-935.0	with Check Valve
9.802-160.0	without Check Valve

**FILTERS - CHEMICAL LINES WITH FILTER**



- 6-Foot Long, 1/4" Clear Vinyl Tubing

PART NO.	DESCRIPTION	PSI
8.903-991.0	Chemical Line, Filter with Check Valve	Brass Filter
8.903-993.0	Chemical Line, Filter with Check Valve	Plastic Filter
8.903-996.0	Chemical Line, Filter without Check Valve	Plastic Filter

**FILTERS - IN-LINE - HEAVY-DUTY**



- PSI Max: 145
- GPM Max: 8
- Temperature Max: 140°F
- 1/2" Female x Male
- 50-Mesh Screen
- Unbreakable Reinforced Nylon Cap

PART NO.	DESCRIPTION	PSI
8.709-974.0	Filter	145
8.709-975.0	Filter with Auxiliary Bypass Port	145
8.704-172.0	Replacement Filter	145

**FILTERS - IN-LINE - ALL METAL**

Diecast aluminum body & cover with a black anodized finish.



- PSI Max: 580
- GPM Max: 6.6
- Temperature Max: 195°F
- 38-Mesh Screen
- 1/2" Female x Male

PART NO.	DESCRIPTION	PSI
8.709-976.0	All Metal In-Line Filter	170

**FILTERS - IN-LINE - GREEN-CAP**

The original Green-Cap!



- PSI Max: 145
- GPM Max: 6
- 50-Mesh Stainless Screen
- Aluminum Housing with a Plastic Cap
- 1/2" FPT Inlet
- 1/2" MPT Outlet
- Two 1/2" MPT Bypass Ports

PART NO.	DESCRIPTION	MAX PSI
8.709-961.0	Green Cap Filer	145
8.701-383.0	Replacement Screen	145
8.701-382.0	Replacement Cap	145
8.702-034.0	Replacement O-Ring	145

**FILTERS - CLEAR BOWL**





- Low-Profile Style
- MPT Inlet and Outlet
- White Nylon Body
- Clear Bowl
- Stainless-Steel Screen
- L3" L x 1-3/4" W x 2-3/8" H





PART NO.	DESCRIPTION	COLOR
8.709-962.0	1/4", 40-Mesh Screen	Clear Bowl
8.709-963.0	1/4", 80-Mesh Screen	Clear Bowl
8.709-964.0	3/8", 40-Mesh Screen	Clear Bowl
8.709-965.0	3/8", 80-Mesh Screen	Clear Bowl
8.709-966.0	1/2", 40-Mesh Screen	Clear Bowl
8.709-967.0	1/2", 80-Mesh Screen	Clear Bowl
8.700-563.0	80-Mesh Replacement Screen	
8.700-564.0	40-Mesh Replacement Screen	

**FILTERS - IN-LINE - CAN-TYPE**



- 40- or 80-Mesh Filtration
- Heavy-duty molded plastic with stainless-steel screen
- Hanger tab standard on 3/8", 1/2" and 3/4"
- Choose Black or Clear Filter Cans

PART NO.	DESCRIPTION	COLOR
<b>40-MESH FILTERS</b>		
8.709-982.0	3/8" Hanger Tab	Black
8.709-986.0	1/2" Hanger Tab	Black
8.709-990.0 	3/4" Hanger Tab	Black
8.709-994.0	1" Hanger Tab	Black
8.710-001.0	1-1/4" Hanger Tab	Black
8.710-003.0	1-1/2" Hanger Tab	Black
8.709-983.0	3/8" Hanger Tab	Clear
8.709-987.0	1/2" Hanger Tab	Clear
8.709-991.0 	3/4" Hanger Tab	Clear
8.709-996.0	1" Hanger Tab	Clear
8.710-002.0	1-1/4" Hanger Tab	Clear
8.710-004.0	1-1/2" Hanger Tab	Clear
<b>80-MESH FILTERS</b>		
8.709-988.0	1/2" Hanger Tab	Black
8.709-992.0	3/4" Hanger Tab	Black
8.709-995.0	1" Hanger Tab	Black
8.710-005.0	1-1/4" Hanger Tab	Black
8.709-999.0	1-1/2" Hanger Tab	Black
8.709-989.0	1/2" Hanger Tab	Clear
8.709-993.0 	3/4" Hanger Tab	Clear
8.709-997.0	1" Hanger Tab	Clear
8.710-006.0	1-1/4" Hanger Tab	Clear
8.710-000.0	1-1/2" Hanger Tab	Clear

PART NO.	DESCRIPTION	COLOR
<b>IN-LINE CAN-TYPE FILTER PARTS - 3/8", 1/2", 3/4"</b>		
8.700-555.0	Gasket	
8.700-557.0	Viton Gasket	
8.700-559.0	Bowl	Black
8.700-560.0 	Bowl	Clear
8.700-565.0	40-Mesh Screen, Blue	
8.700-567.0 	80-Mesh Screen, White	
8.932-949.0	3/8" Top with Tab	
8.700-569.0	1/2" Top with Tab	
8.700-570.0	3/4" Top with Tab	
<b>IN-LINE CAN-TYPE FILTER PARTS - 1", 1-1/4", 1-1/2"</b>		
8.700-556.0 	Gasket	
8.700-558.0	Viton Gasket	
8.700-566.0	1", 40-Mesh Screen	
8.700-575.0	1-1/4", 40-Mesh Screen	
8.700-576.0	1-1/2", 40-Mesh Screen	
8.700-568.0 	1", 80-Mesh Screen	
8.700-577.0	1-1/4", 80-Mesh Screen	
8.700-578.0	1-1/2", 80-Mesh Screen	
8.700-571.0	1" Filter Top	
8.700-573.0	1", 1-1/4", 1-1/2" Bowl	Black
8.700-574.0 	1", 1-1/4", 1-1/2" Bowl	Clear

**FILTERS - IN-LINE - CLEARVIEW**



8.710-145.0      8.710-146.0      8.710-147.0

- Stainless-Steel Screen
- Combination 1/2", 3/4" Hose Barb
- Weighted to hold at bottom of tank or source

PART NO.	DESCRIPTION
8.710-145.0	3/8" NPT x 3/4" GH
8.710-147.0	3/8" NPT x 3/4" GH with 1/4" Bypass
8.710-144.0	1/2" NPT x 3/4" GH
8.710-146.0	1/2" NPT x 3/4" GH with 1/3" Bypass

**STRAINERS - Y TRAP**



- PSI Max: 170
- Temperature Max: 194°F
- Brass Bodies and Cap
- FPT Inlet and Outlet
- Stainless-Steel 50-Mesh Cylinder Screen

PART NO.	DESCRIPTION	MAX PSI
8.709-956.0	1/4" FPT Brass Bodies and Cap	170
8.709-957.0	3/8" FPT Brass Bodies and Cap	170
8.709-958.0	1/2" FPT Brass Bodies and Cap	170
8.709-959.0	3/4" FPT Brass Bodies and Cap	170
8.709-960.0	1" FPT Brass Bodies and Cap	170

**FOOT / CHECK VALVE**

Includes backflow check and perforated screen, prevents damage to pump or control valves.



- Removable Stainless-Steel Screen
- Spring-Loaded Check Valve
- Cast-Brass Bodies
- FPT Outlet

PART NO.	DESCRIPTION	TYPE
8.709-388.0	1/2" Foot Check Valve and Screen	
8.709-389.0	3/4" Spring Check Valve	Brass
8.709-390.0	1" Spring Check Valve	Brass

**FOOT VALVES - SUCTION - ST35 / ST35R**

Weighted to hold at bottom of tank or source.



- Stainless-Steel Screen
- Combination 1/2", 3/4" Hose Barb

PART NO.	DESCRIPTION	TYPE
8.709-970.0	Suction Foot Valve with Check Valve	Stainless-steel Screen

**STRAINERS / TANK SCREEN**

Use for tank drain or chemical line.



- Stainless-Steel Screen - 40 or 50 Mesh
- PVC Base attaches to nipple or tubing

PART NO.	DESCRIPTION	MESH
8.710-008.0	1/4" FPT	50
8.710-010.0	3/8" FPT	50
8.710-011.0	1/2" FPT	40
9.802-162.0	1/2" FPT	50
8.710-013.0	3/4" FPT	40
8.710-014.0	3/4" FPT	50
8.710-015.0	1" FPT	40
8.710-016.0	1-1/2" FPT	40

**FILTERS - IN-LINE - NOZZLE - HIGH-PRESSURE**

Protect your turbo nozzle from damage caused by debris in the water flow.



8.709-978.0



8.710-149.0



8.709-979.0



8.710-150.0

- PSI Max: 5000
- Temperature: 300°F
- 1/4" MPT Outlet
- 100 Mesh Screen

PART NO.	DESCRIPTION	TYPE
8.709-978.0	1/4" FPT Inlet x 1/4" MPT Outlet	Brass
8.709-979.0	1/4" QC Inlet x 1/4" MPT Outlet	Brass
8.710-149.0	1/4" QC Inlet x 1/4" MPT Outlet	416 SS
8.710-150.0	1/4" MPT Inlet x 1/4" MPT Outlet	Brass
8.704-234.0	Replacement filter for 8.709-978.0 / 8.709-979.0	
8.701-201.0	Replacement filter for 8.710-149.0 / 8.710-150.0	

**FILTERS - FUEL**

In-line, disposable.



8.709-942.0



9.802-211.0

PART NO.	DESCRIPTION	TYPE
9.802-211.0	1/4" Inlet / Outlet	Plastic
8.709-942.0	1/4" Inlet / Outlet	Metal
8.709-943.0	3/8" Inlet / Outlet	Plastic

## FILTERS - HIGH-VOLUME

Molded plastic housing.



- PSI Max: 125
- GPM Max: 12 at 50 Micron
- GPM Max: 10 at 5 or 20 Micron
- 3/4" FPT Inlet and Outlet
- 14-1/2" Tall x 5-1/2" Port to Port

PART NO.	DESCRIPTION	MAX PSI
8.710-017.0	Housing only	125
8.753-552.0	Mounting Bracket / Hardware	125
8.700-581.0	Replacement O-ring	125



- Pleated Ployester / Polypropylene Core
- Recommended for large flow, low- pressure applications (up to 60 PSI)

PART NO.	DESCRIPTION	GPM
<b>ULTRA FINE FILTER ELEMENTS</b>		
8.710-019.0	5 Micron	10
8.710-020.0	20 Micron	10
8.710-021.0	50 Micron	12



- Recommended for maximum filtration with reduced flow requirements (up to 130 PSI)

PART NO.	DESCRIPTION	GPM
<b>SYNTHETIC STRING WOUND ELEMENTS</b>		
8.710-022.0	5 Micron	4
8.710-023.0	20 Micron	5
8.710-024.0	50 Micron	6

## FILTERS - FUEL - CLEAR BOWL





- Aluminum Housing
- Non-replaceable 120 mesh stainless-steel screen
- 1/4" x 1/4"
- Clear Acrylic Bowl

PART NO.	DESCRIPTION
8.709-948.0 	Complete Unit

## FILTERS - FUEL / WATER SEPARATOR - LEGACY



- 10 Micron Filtration
- Spin-On Convenience
- Water-Separation Chamber
- 1/4" FPT Inlet / Outlet
- Easy Drain Water / Sediment Bowl

PART NO.	DESCRIPTION
8.725-306.0 	Complete Unit
8.725-307.0* 	Element Only

\*Order 24 for a full case

## FILTERS - BLUE TOP



PART NO.	DESCRIPTION	TYPE
<b>HOUSING</b>		
8.753-559.0	Housing, 5", 1/2" F-F	
8.753-561.0	Housing, 5", 1" F-F	
8.753-562.0	Housing, 10", 1/2" F-F	
<b>CARTRIDGE</b>		
8.753-564.0	Cartridge, 10" Poly Thread	Disposable
8.753-565.0	Cartridge, 5" Poly Thread	Disposable
8.753-566.0	Cartridge, 10" Nylon Mesh	Washable

## FILTERS - FUEL ELEMENT - GENERAL



- Can Type
- GPM Max: 10
- 10 Micron Filtration
- Inexpensive Replacement
- Wool Felt Element

PART NO.	DESCRIPTION
8.709-950.0 	Element Only - 1A-30

**FILTERS - FUEL / WATER SEPARATOR - RACOR**



The "Max" fuel system protector.



- 10 Micron Filtration
- Spin-On Convenience
- Water-Separation Chamber
- 1/4" FPT Inlet / Outlet
- Easy Drain Water / Sediment Bowl

PART NO	DESCRIPTION
9.802-212.0	Complete Unit
8.709-953.0	 Element
8.700-553.0	Plastic Bowl

**FILTERS - FUNNEL - RACOR**



- GPM: 3.9
- Telfon-Coated, Stainless-Steel Filter
- Separates Free Water and Contaminates from Gasoline / Diesel / Kerosene

PART NO.	DESCRIPTION
8.709-955.0	Racor Filter Funnel

**SEWER / TUBE CLEANING NOZZLES - ST-49 & "MINI"**



The reverse jets on the fixed and rotary nozzles pull the hose through the tube or sewer line and blast debris from line or tube walls.



0 -forward, 3 back ports



1 -forward, 4 back ports



1 -forward, 3 back ports





0 -forward, 2 side ports



0 -forward, 2 side ports

- PSI: 4200
- Physically Small for Cornering Ability
- Corrosion-resistant Stainless-steel Construction
- Backward Ports Drive the Nozzle Forward and Flush Debris
- Orifice Size Indicated on Non-rotating Styles
- Forward Ports Blast into Pipe and Breaks Up Clogs and Debris
- Rotating Style Adds Extra Agitation and Surface Cleaning

PART NO.	NOZZLE	ORIFICE SIZE	O.D.	PORTS
<b>NON-ROTATING "MINI" SEWER NOZZLES</b>				
8.710-875.0	1/8"	4.5	.580"	0-Forward, 3 Back
8.710-874.0	1/8"	5.5	.580"	1-Forward, 3 Back
8.710-878.0	 1/4"	4.5	.730"	1-Forward, 3 Back
8.710-876.0	 1/4"	5.5	.730"	1-Forward, 3 Back
8.710-877.0	1/4"	6.0	.730"	1-Forward, 4 Back
8.710-880.0	1/4"	7.5	.730"	1-Forward, 4 Back
8.710-879.0	1/4"	8.0	.730"	1-Forward, 3 Back
8.710-881.0	1/4"	12	.730"	1-Forward, 3 Back
8.710-885.0	3/8"	4.0	.920"	1-Forward, 3 Back
8.710-884.0	 3/8"	5.5	.920"	1-Forward, 3 Back
8.710-886.0	3/8"	8.5	.920"	1-Forward, 4 Back
8.710-883.0	3/8"	12	.920"	1-Forward, 4 Back
8.710-882.0	3/8"	14	.920"	1-Forward, 4 Back

- PSI: 4000
- Rotating Sewer Nozzle
- Adds Extra Agitation
- Back Jet Only

PART NO.	ROTATING NOZZLE	ORIFICE SIZE	PORTS
<b>ST-49 ROTATING SEWER NOZZLES</b>			
8.710-899.0	1/8"	5.5	0-Forward, 3 Back
8.710-898.0	1/4"	5.5	0-Forward, 3 Back
8.710-900.0	1/4"	8.0	0-Forward, 3 Back
8.710-887.0	1/4" Duct Cleaner*	5.5	0-Forward, 2 Side

\*Duct Cleaner jet to sides instead of reverse

**SEWER / TUBE CLEANING NOZZLES**

- PSI: 5000
- Corrosion-resistant Stainless-steel
- One Forward Orifice
- Three Rear Orifices



PART NO.	FPT	SIZE
8.710-905.0	1/8"	5.0
8.710-906.0	1/8"	5.5
8.710-907.0	1/8"	6.0
8.710-908.0	1/4"	6.5
8.710-909.0	1/4"	7.0
8.710-910.0	1/4"	9.5



**NOZZLE SIZE SELECTION CHART**

Determine the nozzle size by the pressure washer's GPM @ PSI (gallons per minute @ a specific pounds per square inch). If the nozzle size is too small, your equipment can be damaged. If the nozzle size is too large, cleaning ability is compromised. Nozzle fan degree does not effect nozzle size selection.

STANDARD NOZZLE SIZE	HOLE SIZE	POUNDS PER SQUARE INCH (PSI)																
		500	750	1000	1250	1500	1750	2000	2250	2500	2750	3000	3250	3500	3750	4000	4500	5000
2	.034"/0.86mm	0.71	0.87	1.00	1.12	1.22	1.32	1.41	1.50	1.58	1.66	1.73	1.80	1.87	1.94	2.00	2.12	2.24
2.5	.042"/1.07mm	0.88	1.08	1.25	1.40	1.53	1.65	1.77	1.88	1.98	2.07	2.17	2.25	2.34	2.42	2.50	2.65	2.80
3	.043"/1.09mm	1.06	1.30	1.50	1.68	1.84	1.98	2.12	2.25	2.37	2.49	2.60	2.70	2.81	2.90	3.00	3.18	3.35
3.5	.048"/1.22mm	1.24	1.52	1.75	1.96	2.14	2.32	2.47	2.63	2.77	2.90	3.03	3.15	3.27	3.39	3.50	3.71	3.91
4	.052"/1.32mm	1.41	1.73	2.00	2.24	2.45	2.65	2.83	3.00	3.16	3.32	3.46	3.61	3.74	3.87	4.00	4.24	4.47
4.5	.055"/1.40mm	1.59	1.95	2.25	2.52	2.76	2.98	3.18	3.38	3.56	3.73	3.90	4.06	4.21	4.36	4.50	4.77	5.03
5	.057"/1.45mm	1.77	2.17	2.50	2.80	3.06	3.31	3.54	3.75	3.95	4.15	4.33	4.51	4.68	4.84	5.00	5.30	5.59
5.5	.06"/1.52mm	1.94	2.38	2.75	3.07	3.37	3.64	3.89	4.13	4.35	4.56	4.76	4.96	5.14	5.33	5.50	5.83	6.15
6	.062"/1.57mm	2.12	2.60	3.00	3.35	3.67	3.97	4.24	4.50	4.74	4.97	5.20	5.41	5.61	5.81	6.00	6.36	6.71
6.5	.064"/1.63mm	2.30	2.81	3.25	3.63	3.98	4.30	4.60	4.88	5.14	5.39	5.63	5.86	6.08	6.29	6.50	6.89	7.27
7	.067"/1.70mm	2.47	3.03	3.50	3.91	4.29	4.63	4.95	5.25	5.53	5.80	6.06	6.31	6.55	6.78	7.00	7.42	7.83
7.5	.070"/1.78mm	2.65	3.25	3.75	4.19	4.59	4.96	5.30	5.63	5.93	6.22	6.50	6.76	7.02	7.26	7.50	7.95	8.39
8	.072"/1.83mm	2.83	3.46	4.00	4.47	4.90	5.29	5.66	6.00	6.32	6.63	6.93	7.21	7.48	7.75	8.00	8.49	8.94
8.5	.074"/1.88mm	3.01	3.68	4.25	4.75	5.21	5.62	6.01	6.38	6.72	7.05	7.36	7.66	7.95	8.23	8.50	9.02	9.50
9	.076"/1.93mm	3.18	3.90	4.50	5.03	5.51	5.95	6.36	6.75	7.12	7.46	7.79	8.11	8.42	8.71	9.00	9.55	10.06
9.5	.078"/1.98mm	3.36	4.11	4.75	5.31	5.82	6.28	6.72	7.13	7.51	7.88	8.23	8.56	8.89	9.20	9.50	10.08	10.62
10	.080"/2.03mm	3.54	4.33	5.00	5.59	6.12	6.61	7.07	7.50	7.91	8.29	8.66	9.01	9.35	9.68	10.00	10.61	11.18
11	.083"/2.11mm	3.89	4.76	5.50	6.15	6.74	7.28	7.78	8.25	8.70	9.12	9.53	9.92	10.29	10.65	11.00	11.67	12.30
12	.087"/2.21mm	4.24	5.20	6.00	6.71	7.35	7.94	8.49	9.00	9.49	9.95	10.39	10.82	11.22	11.62	12.00	12.73	13.42
12.5	.089"/2.26mm	4.42	5.41	6.25	6.99	7.65	8.27	8.84	9.38	9.88	10.36	10.83	11.27	11.69	12.10	12.50	13.26	13.98
13	.091"/2.31mm	4.60	5.63	6.50	7.27	7.96	8.60	9.19	9.75	10.28	10.78	11.26	11.72	12.16	12.59	13.00	13.79	14.53
15	.096"/2.44mm	5.30	6.50	7.50	8.39	9.19	9.92	10.61	11.25	11.86	12.44	12.99	13.52	14.03	14.52	15.00	15.91	16.77
20	.109"/2.77mm	7.07	8.66	10.00	11.18	12.25	13.23	14.14	15.00	15.81	16.58	17.32	18.03	18.71	19.36	20.00	21.21	22.36
25	.125"/3.18mm	8.84	10.83	12.50	13.98	15.31	16.54	17.68	18.75	19.76	20.73	21.65	22.53	23.39	24.21	25.00	26.52	27.95
30	.141"/3.58mm	10.61	12.99	15.00	16.77	18.37	19.84	21.21	22.50	23.72	24.87	25.98	27.04	28.06	29.05	30.00	31.82	33.54
40	.156"/3.96mm	14.14	17.32	20.00	22.36	24.49	26.48	28.28	30.00	31.62	33.17	34.64	36.06	37.42	38.73	40.00	42.43	44.72
50	.172"/4.37mm	17.68	21.65	25.00	27.95	30.62	33.07	35.36	37.50	39.53	41.46	43.30	45.07	46.77	48.41	50.00	53.03	55.90
60	.188"/4.78mm	21.21	25.98	30.00	33.54	36.74	39.69	42.43	45.00	47.43	49.75	51.96	54.08	56.12	58.09	60.00	63.64	67.08

GALLONS PER MINUTE - GPM

**NOZZLE FAN SELECTION**

Select the nozzle degree or spray angle, based on your application. Standard nozzle degrees - 0°, 15°, 25° and 40°. Using the wrong nozzle degree can damage the surface you are cleaning.

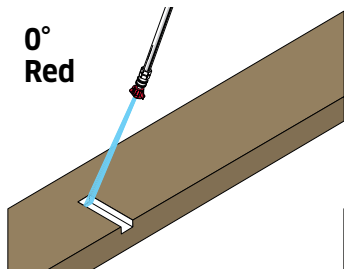
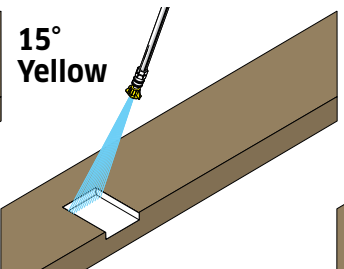
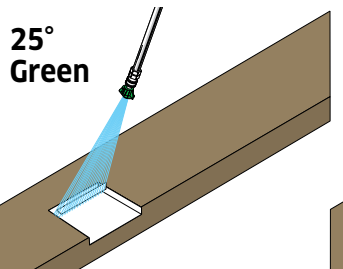
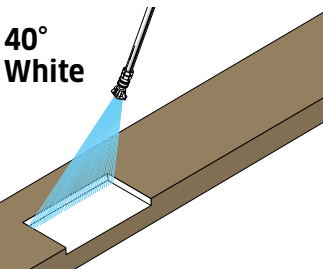
<p><b>0°</b> <b>Red</b></p>  <p><b>CUTTING NOZZLE</b> Delivers a concentrated stream that can gouge or cut. It can cut stubborn stains from concrete and other hard surfaces.</p>	<p><b>15°</b> <b>Yellow</b></p>  <p><b>CHISELING NOZZLE</b> Working at a 45° angle, this nozzle works like a scraper, stripping paint, grease and grime from hard surfaces.</p>	<p><b>25°</b> <b>Green</b></p>  <p><b>FLUSHING NOZZLE</b> Most commonly used nozzle for cleaning dirt from siding, sidewalks and metal furniture as well as wet sweeping leaves.</p>	<p><b>40°</b> <b>White</b></p>  <p><b>WASH NOZZLE</b> Wide spray to wash and rinse large areas quickly. Usually safe for most surfaces, including aluminum siding, windows and vehicles.</p>
---	--	--	---

### NOZZLE SETS - LEGACY - QC 4 & 5 PACKS - COLOR-CODED

1/4" Quick Coupler Nozzle Kits

- Hardened stainless-steel, one-piece body for long life
- High-impact, uniform, flat-spray pattern

- Color-coded by spray angle
- Includes 40 x 65 soap nozzle













**Legacy**



4/PK (0°, 25°, 40° and Soap)



5/PK (0°, 15°, 25°, 40° and Soap)







PART NO.	NOZZLE SIZE	DESCRIPTION
<b>4/PK (0°, 25°, 40° AND SOAP)</b>		
8.726-117.0 	3.0	4 pack Nozzle Kit
9.104-028.0	3.25	4 pack Nozzle Kit
8.726-119.0	3.5	4 pack Nozzle Kit
8.726-120.0 	4.0	4 pack Nozzle Kit
8.726-121.0 	4.5	4 pack Nozzle Kit
8.726-122.0 	5.0	4 pack Nozzle Kit
8.726-123.0	5.5	4 pack Nozzle Kit
8.726-124.0	6.0	4 pack Nozzle Kit
8.726-125.0	6.5	4 pack Nozzle Kit
<b>5/PK (0°, 15°, 25°, 40° AND SOAP)</b>		
9.104-024.0	3.0	5 pack Nozzle Kit
9.104-016.0 	3.25	5 pack Nozzle Kit
8.726-128.0 	3.5	5 pack Nozzle Kit
9.104-030.0 	4.0	5 pack Nozzle Kit
8.726-130.0 	4.5	5 pack Nozzle Kit
8.726-131.0 	5.0	5 pack Nozzle Kit
8.726-132.0 	5.5	5 pack Nozzle Kit
8.726-133.0 	6.0	5 pack Nozzle Kit
8.726-134.0 	6.5	5 pack Nozzle Kit

### NOZZLES - LEGACY - QC - 1/4" COLOR-CODED

Quick connect, Color-coded, hardened stainless nozzle. Fits msot 1/4" quick couplers. Rated for 4000 PSI.

**Legacy**



ORIFICE	PART NO. 0°	PART NO. 15°	PART NO. 25°	PART NO. 40°
<b>QC NOZZLES</b>				
	<b>RED</b>	<b>YELLOW</b>	<b>GREEN</b>	<b>WHITE</b>
3.0	 8.723-576.0	8.902-482.0	8.902-484.0	8.902-485.0
3.25	 8.708-538.0	8.708-539.0	8.708-540.0	8.708-541.0
3.5	 8.723-577.0	8.726-104.0	8.708-526.0	8.902-487.0
3.75	8.708-527.0	8.708-528.0	8.708-529.0	8.708-530.0
4.0	 8.708-531.0	8.708-532.0	8.708-533.0	8.708-534.0
4.5	 8.723-578.0	8.708-535.0	8.708-536.0	8.708-537.0
5.0	 8.726-105.0	8.726-106.0	8.726-107.0	8.726-108.0
5.5	 8.723-579.0	8.902-492.0	8.708-542.0	8.902-493.0
6.0	8.726-109.0	8.726-110.0	8.726-111.0	8.726-112.0
6.5	8.726-113.0	8.726-114.0	8.726-115.0	8.726-116.0

PART NO.	ORIFICE	DEGREE
<b>QC SOAP NOZZLES</b>		
8.723-636.0 	40	65°

## NOZZLES

### NOZZLE SETS - GP - QC 4 & 5 PACKS - COLOR-CODED

Nozzle sets of quick coupler nozzles



- 4-pack Set : 0°, 15°, 25° and 40°
- 5-pack also includes one 40 x 65° soap nozzle.

PART NO.	NOZZLE SIZE
<b>4/PK (0°, 15°, 25° AND 40°)</b>	
8.708-712.0	3.5
8.708-713.0	4.0
8.708-714.0	4.5
8.708-715.0	5.0
8.708-716.0	5.5
8.708-717.0	6.0
8.708-718.0	6.5

PART NO.	NOZZLE SIZE
<b>5/PK (0°, 15°, 25°, 40° AND SOAP)</b>	
9.104-014.0	3.5
8.708-721.0	4.0
9.104-015.0	4.5
8.708-723.0	5.0
8.708-724.0	5.5
8.708-725.0	6.0
8.708-726.0	6.5

### NOZZLES - QC - 1/4" - Q-STYLE



- Rated for 5000 PSI
- Quick-coupled
- Color-coded
- Hardened stainless nozzles fit most 1/4" quick couplers

	RED	YELLOW	GREEN	WHITE
ORIFICE	PART NO. 0°	PART NO. 15°	PART NO. 25°	PART NO. 40°
2.0	8.708-644.0	8.712-322.0	8.708-645.0	8.708-652.0
2.5	8.708-647.0	8.708-648.0	8.708-649.0	8.708-651.0
3.0	9.802-287.0	8.712-333.0	8.712-334.0	8.712-335.0
3.5	9.802-291.0	8.712-338.0	8.712-339.0	8.712-340.0
4.0	9.802-295.0	8.712-346.0	8.712-347.0	8.712-348.0
4.5	9.803-810.0	8.712-350.0	8.712-351.0	8.712-352.0
5.0	9.802-299.0	8.712-354.0	8.712-355.0	8.712-356.0
5.5	9.802-303.0	8.712-358.0	8.712-359.0	8.712-360.0
6.0	9.802-307.0	8.712-362.0	8.712-363.0	8.712-364.0
6.5	8.708-681.0	8.708-682.0	8.708-683.0	8.708-684.0
7.0	9.803-800.0	9.803-801.0	9.803-802.0	9.803-803.0
7.5	8.708-689.0	8.708-690.0	8.708-691.0	8.708-692.0
8.0	8.708-693.0	8.708-694.0	8.708-695.0	8.708-696.0
8.5	8.708-697.0	8.708-698.0	8.708-699.0	8.708-700.0
9.0	8.708-701.0	8.712-379.0	8.708-703.0	8.712-381.0
10.0	8.708-705.0	8.708-706.0	8.708-707.0	8.708-708.0



## NOZZLES - MEG - 1/4" - M-STYLE

Hardened stainless-steel nozzle insert ensures consistent, accurate orifice size



- 1/4" male pipe thread nozzles
- Rated up to 5000 PSI
- 303 Series Stainless-steel

ORIFICE	PART NO. 0°	PART NO. 15°	PART NO. 25°	PART NO. 40°
2.5	-	8.708-569.0	8.708-650.0	8.708-570.0
3.0	8.708-572.0	8.711-370.0	8.708-574.0	8.708-575.0
3.5	8.708-576.0	8.708-577.0	8.708-578.0	8.708-579.0
4.0	8.708-580.0	8.708-581.0	8.708-582.0	8.708-583.0
4.5	8.708-584.0	8.708-585.0	8.708-586.0	8.708-587.0
5.0	8.708-588.0	8.708-589.0	8.708-590.0	8.708-591.0
5.5	8.708-592.0	8.708-593.0	8.708-594.0	8.708-595.0
6.0	8.708-596.0	8.708-597.0	8.708-598.0	8.708-599.0
6.5	8.708-600.0	8.708-601.0	8.708-602.0	8.708-603.0
7.0	8.708-604.0	8.708-605.0	8.708-606.0	8.708-607.0
7.5	8.708-608.0	8.708-609.0	8.708-610.0	8.708-611.0
8.0	8.708-612.0	8.708-613.0	8.708-614.0	8.708-615.0
8.5	8.708-616.0	8.708-617.0	8.708-618.0	8.708-619.0
9.0	8.708-620.0	8.708-621.0	8.708-622.0	8.708-623.0
10.0	8.708-624.0	8.708-625.0	8.708-626.0	8.708-627.0

## NOZZLES - SOAP NOZZLES

Ideal for low-pressure chemical applications



- Brass
- Large #40 Orifice
- 15° or 65° Spray Angle.

PART NO.	ORIFICE	DEGREE
<b>1/4" QC</b>		
9.802-311.0	40	65°
8.708-711.0	50	15°
<b>1/8" MEG</b>		
8.708-410.0	40	65°
<b>1/4" MEG</b>		
8.708-268.0	40	65°
8.708-277.0	50	15°

## NOZZLE HOLDER GROMMET



PART NO.	DESCRIPTION
8.710-343.0	1/16" x 15/16" x 3/8"

**NOZZLES - MEG - 1/4" MALE THREADS**

1/4" male pipe thread meg nozzles, rated up to 4000 PSI. Hardened stainless-steel nozzle ensures consistent, accurate orifice size.

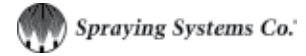

- PSI: 4000
- Orifice Recessed for Protection
- Flow-Rated Tolerance of + 2% at 70°F
- Hard-edge pattern, light center requires overlap to cover center
- 400 Series Stainless-steel

ORIFICE	PART NO. 0°	PART NO. 15°	PART NO. 25°	PART NO. 40°
2.0	8.707-637.0	8.707-640.0	8.707-643.0	8.707-648.0
2.5	8.707-646.0	8.707-650.0	8.707-653.0	8.707-652.0
3.0	 8.707-655.0	8.707-657.0	8.707-659.0	8.707-661.0
3.5	8.707-662.0	8.707-664.0	8.707-666.0	8.707-667.0
4.0	 8.707-669.0	8.707-671.0	8.707-673.0	8.707-675.0
4.5	 8.707-678.0	8.707-679.0	8.707-680.0	8.707-681.0
5.0	 8.707-683.0	8.707-686.0	8.707-688.0	8.707-691.0
5.5	 8.707-694.0	8.707-695.0	8.707-697.0	8.707-698.0
6.0	 8.707-700.0	8.707-702.0	8.707-703.0	8.707-705.0
6.5	8.707-708.0	8.707-710.0	8.707-711.0	8.707-712.0
7.0	8.707-713.0	8.707-715.0	8.707-716.0	8.707-717.0
7.5	8.707-718.0	8.707-719.0	8.707-721.0	8.707-722.0
8.0	8.707-723.0	8.707-726.0	8.707-727.0	8.707-729.0
8.5	8.707-734.0	8.707-735.0	8.707-736.0	8.707-738.0
9.0	8.707-739.0	8.707-741.0	8.707-743.0	8.707-746.0
10.0	8.707-747.0	8.707-751.0	8.707-754.0	8.707-756.0
11.0	8.707-760.0	8.707-761.0	8.707-762.0	8.707-763.0
12.0	8.707-764.0	8.707-766.0	8.707-767.0	8.707-768.0
12.5	8.707-769.0	8.707-770.0	8.707-771.0	8.707-772.0
13.0	8.707-773.0	8.707-774.0	8.707-776.0	8.707-778.0
15.0	8.707-782.0	8.707-787.0	8.707-789.0	8.707-790.0
20.0	8.707-795.0	8.707-800.0	8.707-802.0	8.707-804.0
25.0	8.707-807.0	8.707-811.0	8.707-812.0	8.707-813.0
30.0	 8.707-814.0	8.707-817.0	8.707-818.0	8.707-819.0
40.0	 8.707-821.0	8.707-824.0	8.707-826.0	8.707-827.0
50.0	8.707-828.0	8.707-830.0	8.707-832.0	8.707-833.0
60.0	 8.707-834.0	8.707-835.0	8.707-837.0	8.707-838.0

PART NO.	NOZZLE SIZE
<b>8.700-561.0</b>	1/4" Small 2.0 - 20.0 Meg

**NOZZLES - MEG - 1/8" - "WASHJET"**

1/8" male pipe thread meg nozzles, rated up to 4000 PSI. Hardened stainless-steel nozzle ensures consistent, accurate orifice size.



- PSI: 4000
- Orifice Recessed for Protection
- Flow-Rated Tolerance of + 2% at 70°F
- Hard-edge pattern, light center requires overlap to cover center
- 400 Series Stainless-steel

ORIFICE	PART NO. 0°	PART NO. 15°	PART NO. 25°	PART NO. 40°
2.0	 8.707-529.0	8.707-536.0	8.707-537.0	8.707-538.0
2.5	-	8.707-539.0	8.711-465.0	-
3.0	8.707-540.0	8.707-542.0	8.707-543.0	8.707-544.0
3.5	-	8.707-545.0	8.707-546.0	-
4.0	 8.707-547.0	8.707-549.0	8.707-550.0	8.707-551.0
4.5	8.707-552.0	8.707-554.0	8.707-556.0	8.707-557.0
5.0	8.707-558.0	8.707-559.0	8.707-561.0	8.707-564.0
5.5	8.707-567.0	8.707-568.0	8.707-569.0	8.707-570.0
6.0	8.707-571.0	8.707-572.0	8.707-573.0	8.707-575.0
6.5	8.707-577.0	8.707-578.0	8.707-579.0	8.707-581.0
7.0	8.707-582.0	8.707-584.0	8.707-585.0	8.707-586.0
7.5	8.707-588.0	8.707-589.0	8.707-591.0	8.707-592.0*
8.0	8.707-593.0	8.707-594.0	8.707-595.0	8.707-596.0
8.5	8.707-598.0	8.707-599.0	8.707-600.0	8.707-601.0
9.0	8.707-602.0	8.707-604.0	8.707-605.0	8.707-607.0
9.5	-	8.707-609.0	8.707-610.0	8.707-611.0
10.0	8.707-612.0	8.707-613.0	8.707-614.0	8.707-616.0
11.0	8.707-618.0	8.707-619.0	8.707-620.0	-
12.0	8.707-621.0	-	-	8.707-623.0
15.0	8.707-625.0	8.707-626.0	8.707-627.0	-



**NOZZLES - QC "WASH JET"**

"QC" or Quick Connect Hardened Stainless Meg Nozzle, fits most 1/4" quick couplers. Rated for 4000 PSI..

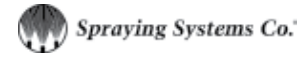

- PSI: 4000
- Temperature: 300°F
- Flow-Rated Tolerance of + 2%
- Hardened Stainless-Steel
- Fits Hansen and Parker Quick-Couplers

ORIFICE	PART NO. 0° RED	PART NO. 15° YELLOW	PART NO. 25° GREEN	PART NO. 40° WHITE
2.0	-	8.708-415.0	8.708-416.0	-
3.0	8.708-417.0	8.708-418.0	8.708-419.0	8.708-420.0
3.5	8.708-422.0	8.708-423.0	8.708-424.0	8.708-425.0
4.0	8.708-427.0	8.708-428.0	8.708-429.0	8.708-430.0
4.5	8.708-431.0	8.708-432.0	8.708-433.0	8.708-434.0
5.0	8.708-435.0	8.708-436.0	8.708-437.0	8.708-438.0
5.5	8.708-439.0	8.708-440.0	8.708-441.0	8.708-442.0
6.0	8.708-443.0	8.708-444.0	8.708-445.0	8.708-446.0
6.5	8.708-447.0	8.708-448.0	8.708-449.0	8.708-450.0
7.0	8.708-451.0	8.708-452.0	8.708-453.0	8.708-454.0
7.5	8.708-455.0	8.708-456.0	8.708-457.0	8.708-458.0
8.0	8.708-459.0	8.708-460.0	8.708-461.0	8.708-462.0
9.0	-	8.708-463.0	8.708-464.0	8.708-465.0
10.0	8.708-467.0	8.708-468.0	8.708-469.0	8.708-470.0
12.0	8.708-471.0	8.708-472.0	-	8.708-474.0

**NOZZLES - 1/4" VEEJET - BROAD SPRAY STAINLESS-STEEL**

1/4" male pipe thread 303 stainless-steel Vee Jet nozzles, low - to medium-volume up to 500 PSI medium-pressure / special application PSI.

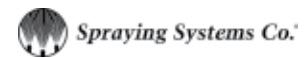

- PSI: 5 Min - 500 Max
- Vee Jet Nozzle
- 303 Stainless-Steel
- GPH: 10.61 to 106 GPH (11.15 to 112 ml/sec)

NOZZLE	ORIFICE DIAMTER	PART NO. 50°	PART NO. 65°	PART NO. 80°	PART NO. 95°	PART NO. 100°
1.0	.026	8.708-074.0	8.708-075.0	8.708-076.0	8.708-078.0	8.708-079.0
1.5	.031	8.708-085.0	8.708-086.0	8.708-087.0	8.708-089.0	8.708-090.0
2.0	.036	8.708-095.0	8.708-096.0	8.708-097.0	8.708-099.0	8.708-101.0
3.0	.043	8.708-108.0	8.708-109.0	8.708-110.0	8.708-112.0	8.708-114.0
4.0	.047	8.708-121.0	8.708-122.0	8.708-123.0	8.708-125.0	8.708-127.0
5.0	.053	8.708-133.0	8.708-134.0	8.708-136.0	8.708-138.0	8.708-140.0
6.0	.058	8.708-148.0	8.708-149.0	8.708-151.0	8.708-155.0	8.708-157.0
7.0	.063	8.708-162.0	8.708-163.0	8.708-164.0	-	8.708-165.0
8.0	.067	8.708-172.0	8.708-173.0	8.708-175.0	8.708-177.0	8.708-179.0



## NOZZLES - 1/4" VEEJET - LOW-PRESSURE - BRASS

1/4" male pipe thread Vee Jet nozzles, brass inexpensive alternative for applications up to 500 PSI.

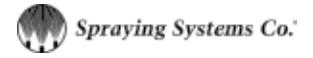

- PSI: Up to 500 PSI
- Feather Edge for Wide Coverage
- Allows Overlap for Even Application
- 1/4" MPT Connects
- Excellent for low-pressure chemical and acid applications
- Uniform spray distribution with flow rates from .012 to 1237 GPM

NOZZLE SIZE	PART NO. 0°	PART NO. 15°	PART NO. 25°	PART NO. 40°	PART NO. 50°	PART NO. 65°
15	8.708-203.0	8.708-204.0	8.708-206.0	8.708-208.0	8.708-210.0	8.708-212.0
20	8.708-218.0	8.708-222.0	8.708-225.0	8.708-228.0	8.708-230.0	8.708-232.0
30	8.708-242.0	8.708-244.0	8.708-246.0	8.708-249.0	8.708-251.0	8.708-253.0
40	8.708-258.0	8.708-260.0	8.708-262.0	8.708-264.0	8.708-266.0	8.708-268.0
50	8.708-275.0	8.708-277.0	8.708-279.0	8.708-280.0	8.708-282.0	8.708-284.0
60	8.708-289.0	8.708-290.0	8.708-292.0	8.708-294.0	8.708-296.0	8.708-297.0
70	8.708-302.0	8.708-304.0	8.708-306.0	8.708-308.0	8.708-309.0	8.708-310.0

## NOZZLE SYSTEM - TIP JET

"Tip-Jet" Nozzle Systems are versatile nozzling systems for everyday or specialized applications. Flat spray, full cone, hollow cone and solid stream patterns, metering orifices and atomizing tips are all available in the Tip-Jet system. Capacities range from .55 to 20 GPM.



- PSI: 4000
- Neat and simple tip change
- Strainers Available
- Hardened stainless-steel tips with vanes for maximum spray integrity
- Body components available in brass, zinc-plated steel or stainless-steel

ORIFICE	PART NO. 0°	PART NO. 15°	PART NO. 25°	PART NO. 40°
3.0	8.708-016.0	8.708-017.0	8.708-018.0	-
4.0	8.708-019.0	8.708-020.0	8.708-021.0	8.708-022.0
4.5	8.708-023.0	8.708-024.0	8.708-025.0	8.708-026.0
5.0	8.708-027.0	8.708-028.0	8.708-029.0	8.708-030.0
5.5	8.708-031.0	8.708-032.0	8.708-033.0	8.708-034.0
6.0	8.708-035.0	8.708-036.0	8.708-037.0	8.708-038.0
6.5	8.708-039.0	-	8.708-040.0	8.708-041.0
7.0	8.708-042.0	8.708-043.0	8.708-044.0	8.708-045.0
10.0	8.708-058.0	8.708-059.0	8.708-060.0	8.708-061.0

## NOZZLE SYSTEM - TIP JET NOZZLE BODIES

Tip-Jet Nozzle Bodies, MPT inlet connections in 1/4", 3/8" and 1/2" sizes. All outlet connections are 11/16" - 16 male thread to fit Tip-Jet tip retainers and adapters.



PART NO.	DESCRIPTION	TYPE
8.707-886.0	MPT 1/4"	Nylon
8.707-898.0	MPT 1/4"	Brass
8.707-899.0	MPT 1/4"	Stainless-steel
8.707-916.0	MPT 1/4"	Polypropylene

## NOZZLES

### NOZZLES - SOAP



"Black" Soap Nozzles are brass with a large #40 orifice. Ideal for low-pressure chemical applications.

PART NO.	SIZE	NOZZLE DEGREE
8.708-478.0	40	25°
8.708-479.0	<b>S</b> 40	65°

### NOZZLE SYSTEM - TIP JET ADAPTER CAPS



Tip-Jet Adapter Caps, similar to tip retainers, but have FPT connections for in-line applications.

PART NO.	DESCRIPTION	TYPE
8.707-919.0	MPT 1/8"	Brass
8.707-921.0	MPT 1/4"	Brass

### NOZZLE SYSTEM - TIP JET RETAINER



Tip Retainer 18 mm thread, fits vent grip lance.

PART NO.	DESCRIPTION
8.710-901.0	Hex Tip Retainer

### NOZZLE SYSTEM - TIP JET RETAINER CAPS



Tip-Jet Retainer Caps, fits all Tip-Jet nozzle bodies, holds spray tips and metering orifices firmly in place.

PART NO.	DESCRIPTION	TYPE
8.707-915.0	Hex	Brass
8.707-918.0	Hex	Plated Steel
8.707-888.0	Hex	Stainless-steel

### NOZZLE SYSTEM - TIP JET STRAINERS



Tip-Jet Strainers fit into nozzle body cavity to stop nozzle clogging.

PART NO.	DESCRIPTION
8.725-693.0	100-Mesh

### NOZZLES - LEGACY REVOLUTION TURBO

Legacy is proud to offer the Revolution rotary nozzle. This turbo rotary nozzle is rated for up to 4350 PSI at 185°F. Turning at an astounding 4,000 RPM, the Revolution delivers faster and deeper cleaning action for the same price of 3000 PSI rotary nozzles.

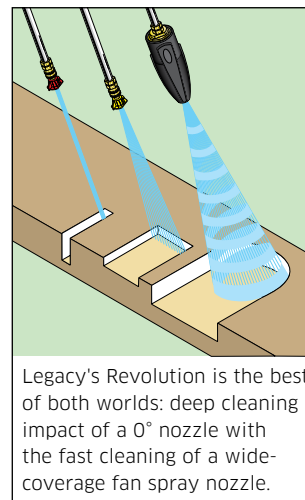

Legacy's Revolution is the best of both worlds: deep cleaning impact of a 0° nozzle with the fast cleaning of a wide-coverage fan spray nozzle.

- Greater Cleaning Power**  
 Engineered to increase impact pressure by more than 10 times that of conventional nozzles
- Longer Operating Life**  
 The Revolution's operating life is extended significantly by its wear-resistant ceramic nozzle and bearing ring
- More Durable and Versatile**  
 The Revolution features an extra-resilient housing protector and is capable of handling a stream up to 4350 PSI at 185°F

PART NO.	ORIFICE	PSI
<b>NOZZLE</b>		
9.302-242.0	<b>S</b> 3.5	4350
9.302-243.0	<b>S</b> 4.0	4350
9.302-244.0	<b>S</b> 4.5	4350
9.302-245.0	<b>S</b> 5.0	4350
9.302-246.0	<b>S</b> 5.5	4350
9.302-247.0	<b>S</b> 6.5	4350
9.302-248.0	<b>S</b> 7.0/8.0	4350
9.302-249.0	<b>S</b> 12.0	4350
<b>REPAIR KIT</b>		
2.884-972.0	3.5	
2.883-824.0	4.0	
9.302-231.0	4.5	
2.883-823.0	5.0	
2.883-822.0	5.5	
9.302-234.0	6.5	
2.883-474.0	7.0-8.0	
2.884-975.0	10.0	
2.884-051.0	12.0	



## NOZZLES - A+ / AP REVOLUTION TURBO

AP Revolution Turbo Nozzle is rated for up to 5000 PSI at 212°F. High-impact nozzle at unbelievable pricing!



- Forged Brass
- Precision Ceramic
- Durable Rubber Cover



PART NO.	ORIFICE	PSI
<b>NOZZLE</b>		
8.726-056.0	3.5	3000
8.726-057.0	4.0	3000
8.726-058.0	4.5	3000
8.726-059.0	5.0	3000
8.726-060.0	5.5	3000
8.726-061.0	6.0	3000
8.726-068.0	3.5	4000
8.726-069.0	4.0	4000
8.726-070.0	4.5	4000
8.726-071.0	5.0	4000
8.726-072.0	5.5	4000
8.726-073.0	6.0	4000
8.726-080.0	3.5	5000
8.726-081.0	4.0	5000
8.726-082.0	4.5	5000
8.726-083.0	5.0	5000
8.726-084.0	5.5	5000
8.726-085.0	6.0	5000

PART NO.	ORIFICE	PSI
<b>REPAIR KIT</b>		
8.726-062.0	3.5	3000
8.726-063.0	4.0	3000
8.726-064.0	4.5	3000
8.726-065.0	5.0	3000
8.726-066.0	5.5	3000
8.726-067.0	6.0	3000
8.726-074.0	3.5	4000
8.726-075.0	4.0	4000
8.726-076.0	4.5	4000
8.726-077.0	5.0	4000
8.726-078.0	5.5	4000
8.726-079.0	6.0	4000
8.726-086.0	3.5	5000
8.726-087.0	4.0	5000
8.726-088.0	4.5	5000
8.726-089.0	5.0	5000
8.726-090.0	5.5	5000
8.726-091.0	6.0	5000

## NOZZLE PROTECTOR - ST-10



Ideal to protect sensitive surfaces against damage. Hard plastic body is stable enough to tightly hold nozzle adapter for heavy-duty use.



- Temperature: 300°F
- 1/4" FPT Inlet / Outlet

PART NO.	DESCRIPTION	TYPE
8.723-668.0	Red / Black	Zinc-plated
8.723-669.0	Black / Gray	Stainless-steel

## NOZZLES - TURBO - A+ NOZZLE KIT



- PSI: 4000
- With 8.726-069.0 Nozzle
- With 8.710-149.0 Inlet Filter



PART NO.	DESCRIPTION	PSI
8.928-444.0	A+ Turbo Nozzle #4 Kit	4000

**NOZZLES - MV ROTOJET 3700 & 5800 TURBO**

0° impact, 25° pattern, no gears - no teeth - no bearings. Exclusive design of the Rotojet 3700 / Rotojet 5800 eliminates start up impact and damage to internal nozzle.

- High-Strength, Forged Brass
- Precision Ceramic Orifice and Matching Race
- Durable Rubber / Plastic Cover
- 1/4" BSPP - \*Note: British pipe thread compatible in-line filters are 8.709-979.0 and 8.709-978.0



**ROTOJET 3700 PSI**

- Temperature: 210°F
- PSI: 1150 Min - 3700 Max



**ROTOJET 5800 PSI  
(MUST START WITH NOZZLE DOWN)**

- Temperature: 200°F
- PSI: 2600 Min - 5800 Max

PART NO.	ORIFICE	PSI
<b>NOZZLE</b>		
8.711-002.0	3.0	3700
8.711-003.0	<b>S</b> 3.5	3700
8.711-005.0	4.0	3700
8.711-004.0	<b>S</b> 4.5	3700
8.711-006.0	<b>S</b> 5.0	3700
8.711-008.0	<b>S</b> 5.5	3700
8.711-007.0	<b>S</b> 6.0	3700
8.711-009.0	3.0	5800
8.711-010.0	3.5	5800
8.711-011.0	<b>S</b> 4.0	5800
8.711-012.0	<b>S</b> 4.5	5800
8.711-013.0	<b>S</b> 5.0	5800
8.711-014.0	5.5	5800
8.711-015.0	6.0	5800
8.711-016.0	6.5	5800
8.711-017.0	7.0	5800
8.711-018.0	8.0	5800
8.711-019.0	9.0	5800
8.711-020.0	10.0	5800
8.711-023.0	11.0	5800
8.711-021.0	12.0	5800

PART NO.	ORIFICE	PSI
<b>REPAIR KIT</b>		
8.704-039.0	3.0	3700
8.704-038.0	3.5	3700
8.704-040.0	4.0	3700
8.704-041.0	4.5	3700
8.704-042.0	5.0	3700
8.704-043.0	5.5	3700
8.704-044.0	6.0	3700
8.704-066.0	3.5	5800
8.704-067.0	4.0	5800
8.704-068.0	4.5	5800
8.704-069.0	5.0	5800
8.704-070.0	5.5	5800
8.704-071.0	6.0	5800
8.704-072.0	6.5	5800
8.704-073.0	7.0	5800
8.704-074.0	8.0	5800
8.704-075.0	9.0	5800
8.704-076.0	10.0	5800
8.704-077.0	11.0	5800
8.704-078.0	12.0	5800

## NOZZLES - 3650 & 5100 PSI TURBO

Provides great impact and cleaning power

- Temperature: 212°F



Turbo Nozzle  
PSI: 1150 Min - 3650 Max



Turbo Nozzle  
PSI: 2600 Min - 5100 Max

PART NO.	ORIFICE	PSI
<b>NOZZLE</b>		
8.711-105.0	3.0	3650
8.711-097.0	3.5	3650
8.711-098.0	4.0	3650
8.711-099.0	4.5	3650
8.711-100.0	5.0	3650
8.711-101.0	5.5	3650
8.711-102.0	6.0	3650
8.711-096.0	6.5	3650
8.711-103.0	7.0	3650
8.711-104.0	8.0	3650
8.711-086.0	3.0	5100
8.711-087.0	3.5	5100
8.711-088.0	4.0	5100
8.711-089.0 	4.5	5100
8.711-090.0	5.0	5100
8.711-091.0	5.5	5100
8.711-092.0	6.0	5100
8.711-093.0	6.5	5100
8.711-094.0	7.0	5100
8.711-095.0	8.0	5100

PART NO.	DESCRIPTION
<b>REPAIR KIT - TURBO NOZZLES 3650 AND 5100 PSI</b>	
8.749-913.0	Repair Kit 3.5
8.749-914.0	Repair Kit 4.0
8.749-915.0	Repair Kit 4.5
8.749-916.0	Repair Kit 5.0
8.749-917.0	Repair Kit 5.5
8.749-920.0	Repair Kit 7.0
8.749-921.0	Repair Kit 8.0

## NOZZLES - ST-357 & ST-457 TURBO



- 1/4" FPT
- Forged Brass
- Precision Ceramic Orifice
- Rubber Cover / Protector



ST-357  
PSI: 1150 Min - 3652 Max  
Temperature: 190°F



ST-457 - 6000 PSI  
PSI: 2600 Min - 6000 Max  
Temperature: 212°F

PART NO.	ORIFICE	PSI
<b>NOZZLE</b>		
8.710-986.0	3.0	3625
8.710-987.0	3.5	3625
8.710-989.0	4.0	3625
8.710-988.0	4.5	3625
8.710-991.0	5.0	3625
8.710-993.0	5.5	3625
8.710-992.0	6.0	3625
8.711-072.0	3.0	6000
8.711-073.0	3.5	6000
8.711-074.0	4.0	6000
8.711-075.0	4.5	6000
8.711-076.0	5.0	6000
8.711-077.0	5.5	6000
8.711-078.0	6.0	6000
8.711-079.0	7.0	6000
8.711-080.0	8.0	6000
8.711-081.0	10.0	6000
<b>REPAIR KIT</b>		
8.701-570.0	3.0	3625
8.701-569.0	3.5	3625
8.701-564.0	4.0	3625
8.701-562.0	4.5	3625
8.701-565.0	5.0	3625
8.701-568.0	5.5	3625
8.701-566.0	6.0	3625
8.701-572.0	3.0	6000
8.701-571.0	3.5	6000
8.701-573.0	4.0	6000
8.701-574.0	4.5	6000
8.701-575.0	5.0	6000
8.701-576.0	5.5	6000
8.701-577.0	6.0	6000
8.701-578.0	7.0	6000
8.701-579.0	8.0	6000
8.701-580.0	10.0	6000



## NOZZLES

### NOZZLES - TURBO - IDK & DK SERIES - DIRT KILLER

4700 maximum PSI, a popular model providing great impact and cleaning power.



8.712-429.0

- Temperature Max: 180°F
- 1/4" Inlet
- IDK Series: Commonly used for Water Blasting and Heavy Duty Cleaning of Concrete, Steel, etc.
- DK Series: Commonly used for warehouse floors, wash rooms, alleyways etc.

PART NO.	SERIES	ORIFICE	PSI
<b>NOZZLE</b>			
8.712-429.0	DK	045	3200
8.740-148.0	IDK	055	4700
<b>REPAIR KIT</b>			
8.701-160.0	DK Kit	045	3200
8.701-161.0	IDK Kit	055	4700

### NOZZLES - TURBO MV ROTATING SOFT / HARD

The cleaning efficiency of a high-pressure rotating nozzle with the feature of changing from a hard spray for concrete to a soft spray for wood by simply pushing or pulling the finger protected nozzle.



- PSI: 3700
- Temperature: 200°F

PART NO.	ORIFICE	PSI
8.711-055.0	045	3700

### NOZZLES - VIPER ROTATING



- PSI: 5000
- Temperature Max: 190°F
- 1/4" FPT Inlet
- Weight: 1.0 oz.

PART NO.	STD NOZZLE EQUIV	PSI
<b>NOZZLE - VIPER</b>		
8.711-000.0	4.5	5000
8.711-001.0	5.5	5000
<b>REPAIR KIT</b>		
8.701-163.0	4.5	5000
8.701-166.0	5.5	5000

### NOZZLES - MV TRIPLE-FUNCTION

Provides three cleaning options: low-pressure for soap or chemical application; a 15° angle for high-pressure cleaning; and a rotating nozzle for maximum cleaning efficiency.



- PSI: 3000
- Temperature: 210°F

PART NO.	ORIFICE	PSI
8.711-068.0	040	3000

### NOZZLES - ZRMAX & ZROTOMAX ROTATING



- PSI: Up to 5800 Max
- Temperature Max: 176°F
- 1/4" FPT Inlet

- Weight: 9 oz..
- Replaceable Stainless-Steel Orifices



PART NO.	DESCRIPTION	STD NOZZLE EQUIV	GPM	PSI
8.711-035.0	ZROTOMAX1	4.5	2.1 - 2.6	1450 -3500
8.711-036.0	ZROTOMAX2	5.5	2.9 - 4.0	1450 -3500
8.711-037.0	ZROTOMAX3	6.5	4.2 - 5.5	1450 -3500
8.711-038.0	ZRMAX581	4.5	2.3 - 4.7	5800
8.711-039.0	ZRMAX583	6.5	3.3 - 6.6	5800
8.701-532.0	Repair Kit			

## COUPLERS - LANCE & NOZZLE COUPLERS

Changes MPT lance to FPT for mounting MPT nozzles.



PART NO.	DESCRIPTION
<b>BRASS</b>	
8.705-150.0	1/8" x 1/8"
8.705-155.0	1/4" x 1/8"
8.705-151.0	1/4" x 1/4"
<b>STEEL</b>	
8.710-713.0	1/8" x 1/8"
8.710-712.0	1/4" x 1/8"
8.710-714.0 	1/4" x 1/4"

## NOZZLES - ROTOJET 2500

Economy turbo nozzle.



- PSI Max: 2000
- Temperature Max: 140°F
- 1/4" FPT Inlet
- Weight: 5.4 oz..
- Great for economy washers

PART NO.	ORIFICE	PSI
8.711-026.0	3.0	2500
8.711-027.0	3.5	2500

## NOZZLES - A+ MULTI-FAN

Adjust from maximum Impact Zero Stream to 80° wide-angle spray with a twist of the nozzle body.



- PSI: 3000
- Temperature: 300°F
- 1/4" FPT Connect
- Stainless-Steel Replaceable Orifices
- Stainless-Steel Deflector .

PART NO.	ORIFICE	COLOR
8.710-932.0	3.0	Yellow
8.710-933.0	3.5	White
8.710-934.0	4.0	Blue
8.710-935.0	4.5	Brown
8.710-936.0	5.0	Green
8.710-937.0	5.5	Light Blue
8.710-942.0	8.0	-

## NOZZLE FILTERS - 1/4" HIGH-PRESSURE

Turbo nozzle protector.



8.709-978.0



8.709-979.0



8.710-150.0



8.710-149.0

- PSI Max: 5000
- GPM: 8.0
- Temperature: 300°F
- 1/4" MPT Outlet
- 100-Mesh SS Screen

PART NO.	TYPE	INLET	OUTLET
8.709-978.0	Brass	1/4" FPT	1/4" MPT
8.709-979.0	Brass	1/4" QC	1/4" MPT
8.710-149.0	416 SS	1/4" QC	1/4" MPT
8.710-150.0	Brass	1/4" MPT	1/4" MPT
8.704-234.0	Replacement Filter for 8.709-978.0 / 8.709-979.0		
8.701-201.0	Replacement Filter for 8.710-149.0 / 8.710-150.0		

## NOZZLES - DUO-REG

Duo-Reg nozzles are designed for industrial use in ALL applications. Easy push / pull, low-to-high pressure change, and easy-turn to adjust from 0° to 80° fan pattern.



- PSI: 3200
- GPM: 8.0
- Temperature: 300°F
- 1/4" FPT Connect
- Stainless-Steel Replaceable Orifices
- Tough Glass-Filled Nylon Cover
- Compact Size: 3-3/8" Long, 1-3/16" Diameter
- Weight: 5.7 oz..

PART NO.	ORIFICE	COLOR
8.710-959.0	3.0	Yellow
8.710-960.0	3.5	White
8.710-961.0	4.0	Blue
8.710-962.0	4.5	Brown
8.710-963.0	5.0	Green
8.710-964.0	5.5	Sky
8.710-965.0	6.0	Black
8.710-966.0	6.5	Dark Green

## NOZZLES

### REPLACEMENT ORFICES

Replacement orifices for Duo-Reg and Multi-fan nozzles.



PART NO.	ORIFICE
8.701-448.0	1.20 MM = 3.0 GPM
8.701-452.0	1.25 MM = 4.5 GPM

### NOZZLE HOLDER / HEAD - ST-56 ROLLOVER



- PSI Max: 3600
- GPM: 8
- Temperature: 300°F
- 1/4" FPT Inlet and Outlet
- Brass Body
- Glass-Filled Polyimide Cover

PART NO.	DESCRIPTION	PSI
8.710-895.0	Rollover Nozzle Head	3600

### NOZZLE HOLDER - ST-51N ADJUSTABLE



Nozzle holder allows water to be diverted around the fixed orifice nozzle, dropping the pressure and allowing the chemical injector to operate.



- PSI Max: 3600
- Temperature Max: 300°F
- GPM Max: 8.0
- Attaches to 1/4" MPT Lance
- Accepts 1/4" Meg Nozzles
- Weight: 5.9 oz.

PART NO.	DESCRIPTION	PSI
8.710-889.0	ST-51N	3600

### NOZZLE HOLDER - ST-330 - SWIVELING



Perfect For cleaning hard-to-reach areas. Nozzle position locks with pressure.



- PSI: 5070
- GPM: 10
- Temperature: 300°F
- Stainless-Steel
- 1/4" Female Inlet

PART NO.	DESCRIPTION
8.749-905.0	Outlet 1/4" FNPT
8.749-906.0	Outlet 1/4" Male

### NOZZLES - HL250 VARI HI-LOW ANGLE



Push / Pull for easy change between high- and low-pressure; simple twist to adjust 0° - 80° spray fan pattern.



- PSI Max: 4050
- Temperature: 195°F
- 1/4" FPT Inlet
- Weight: 4 oz..
- Glass-Filled Nylon Cover
- Stainless-Steel Replaceable Orifice

PART NO.	ORIFICE	COLOR
8.710-972.0	2.0	Light Green
8.710-973.0	2.5	Pink
8.710-974.0	3.0	White
8.710-975.0	3.5	Brown
8.710-976.0	4.0	Dark Yellow
8.710-977.0	4.5	Blue
8.710-978.0	5.0	Purple
8.710-979.0	5.5	Dark Red
8.710-980.0	6.0	Dark Green
8.710-982.0	7.0	Orange
8.710-983.0	8.0	Silver

### NOZZLE HOLDER - DOUBLE

Up to 10 GPM flow for low side pressure, 250 PSI.



- PSI Max: 3200
- Temperature Max: 195°F
- 1/4" Female Inlet, Two Female Outlets
- Heavy Nickel-Plate
- Chemical-Resistant
- Stainless-Steel Ball
- Machined-Brass Body
- New Ball Guide and Seat

PART NO.	DESCRIPTION	PSI
8.710-897.0	 Double Nozzle Head	3200

### NOZZLE HOLDER - PIVOT



- Allowable 120° Pivoting
- Works with standard quick connect nozzles
- 1/4" Quick Connect plug x 1/4" Quick Connect Socket

PART NO.	DESCRIPTION	PSI
8.756-103.0	 Pivoting Nozzle	4000



## NOZZLES - VARIABLE ANGLE

Up to 10 GPM flow for low side pressure, 250 PSI.



- PSI: 1450
- Steam Nozzle - 1/4" F
- Steam Blank - 3/8" M
- One-Piece Brass

PART NO.	DESCRIPTION	TYPE	PSI
8.710-971.0	Variable Angle Nozzle	One-piece Brass	1450

## X-JET LONG RANGE NOZZLE

Includes 15' Hose with In-Line Shut-Off Valve and Color-Coded Proportioners.



- Projects Water and Chemical Up To 40'
- Chemicals Bypass Pump, Lance, Hose and Gun For Damage Protection

8.710-474.0

PART NO.	DESCRIPTION
8.710-474.0*	X-Jet Long Range Nozzle, 2000-3000 PSI
8.710-475.0*	X-Jet Long Range Nozzle, 3000-4000 PSI
8.710-473.0	M5 X-Jet Variable Fan, 2000-3000 PSI, Long Range Nozzle

\*Includes Close Range Nozzle

## NEW OFFERING NOZZLES - STEAM



PART NO.	DESCRIPTION
9.112-956.0	DSN14F Steam Nozzle, 1/4" NPT-F Drill-to-Size Brass with 2.0 Opening

## NOZZLES - STEAM



Steam Nozzle Blank

Flat Steam Nozzle

- PSI: 1450
- Steam Nozzle - 1/4" F
- Steam Blank - 3/8" M
- One-Piece Brass

PART NO.	DESCRIPTION
8.710-958.0	Flat Stream Nozzle, 1.5 mm
8.710-957.0	Steam Nozzle Blank, Drill to Size
8.904-374.0	Nozzle Blank, Drilled to 1.6 mm
8.712-415.0	Steam Nozzle, Drilled to 5/64"

## NOZZLES - ADJUSTABLE

Compact, full-feature unit weighs only 4.3 oz., same functions as ST-51N.



- PSI Max: 3650
- Temperature Max: 300°F
- GPM Max: 8.0
- Machined-Brass Body
- Nylon Adjustment Knob
- 1/4" FPT Inlet / Outlet

PART NO.	DESCRIPTION	PSI
8.710-891.0	Adjustable Nozzle	3650

## JROD MULTI-NOZZLE HOLDER



A handy tool that allows switching quickly between four different nozzles on one spray gun wand. Works great for changing between foam and water, reaching multiple height levels, or altering the intensity of the spray without having to carry around several individual nozzles



- 304 Stainless-steel
- Fits 1/4" NPT-M Thread Nozzles
- Turns each nozzle into a Quick-connect Tip

PART NO.	DESCRIPTION
9.112-496.0	JRod Multi-Nozzle Holder

## NOZZLES

### NOZZLE HOLDER - ROLLOVER - TWIST TYPE

Holds two meg nozzles on opposite sides for positive change from chemical application to high-pressure rinse.



- PSI Max: 1000
- Temperature: 180°F
- Nickel-Plated Brass Body

PART NO.	DESCRIPTION	PSI
8.710-893.0	Dual 1/4" FPT In / Out	1000
8.900-022.0	Repair Kit	1000

### NOZZLE PROTECTOR / COUPLER



- Protect Nozzles and Finished Surfaces
- Deep Nozzle Recess
- Tough Plastic Protector
- 1/4" FPT Coupler Inlet

PART NO.	NOZZLE
8.710-866.0	1/8"
8.710-867.0	1/4"

### NOZZLE PROTECTOR - SLIP-ON

A durable, easy-to-use nozzle protector. Plastic rubber compound - flexible and tough!



- 1-1/2" Diameter at Flare-End
- Slip-Fits Standard Lances
- 2-1/2" Long
- Weight: 1.2 oz..
- Slip-On to Lance
- Attach Nozzle Coupler and Nozzle
- Slide protector forward for complete nozzle protection

PART NO.	DESCRIPTION
8.710-868.0	Slip-on Nozzle Protector

### FOAMERS - LEGACY COMPACT

Generates a high-density clinging foam for extended dwell time to increase chemical action.



- PSI Max: 2500
- Temperature Max: 195°F
- GPM Max: 1-5
- 4 and 6.5 Nozzle Included
- 5" Long, 1" Diameter
- Stainless-Steel, Aluminum and Brass

PART NO.	DESCRIPTION	PSI
8.903-998.0	1/8" F Inlet	2500
8.903-999.0	1/4" F Inlet	2500



Note: Most cleaning chemicals perform best when at 120° - 150°F and can be applied as a foam by adding a foaming agent. See your chemical supplier to obtain the correct products.

### FOAMERS - FOAM CANNON

The ideal foam generator application accessory meters the foaming chemical for customized foam type and applies the foam to match the application.



- PSI Max: 3200
- Temperature Max: 140°F
- GPM Max: 6.5
- Brass Meter Valve
- 1/4" FPT Lance Connect
- High-Impact Glass-Filled Body
- Stainless-Steel 1.5 mm Orifice (#5.5 Nozzle Equivalent)
- Stainless-Steel Foam Turbulator

PART NO.	DESCRIPTION
8.710-125.0	 Foam Cannon / Injector
8.710-126.0	 Foam Cannon / Injector / Bottle
8.704-222.0	Replacement Turbulator Screen



**LEGACY HD PUMP - THE MOST DURABLE PUMP ON THE MARKET**



Legacy HD heavy-duty, high pressure pumps are the outcome of years of research and development, resulting in a number of upgrades over previous pump models. Premium, long-life components and design features make the Legacy HD pump a standout among other high-pressure pumps. Tests prove it holds up better in rugged working conditions.

- Stronger crankcase housing with thicker aluminum cross members and mounting feet for added strength.
- Crankcase features longer overall length to ensure less stress on all parts and a longer life of the pump.
- Super-strong, two-piece connecting rods designed with double-feeder grooves to maximize lubrication for a dramatically cooler running pump.
- Oil level dipstick is vented allowing for heat expansion. Oil level sight glass allows for quick and easy oil inspection.
- Premium European-quality tapered roller bearings on both the drive-side and opposite drive-side of the pump allow for heavier and demanding loads while greatly reducing noise levels and heat build-up.
- Precision machined crankshafts for easy assembly and disassembly. Solid-shaft models have a full 55 mm shaft length to easily accept pulley and sheaves.
- Polished stainless-steel plunger rod reduces friction heat for a smoother and cooler operation.
- Precision-ground and highly-polished solid ceramic plungers designed and manufactured to withstand dramatic temperature and pressure spikes.
- High-temperature, long life U-seals correctly fitted for each pump.
- Dacromet® finish on manifold bolts adds extra rust protection.
- Revolutionary forged-brass heads with exclusive "deep-well-sealing" valve caps eliminate any head pressure effects to the valve cap and valve cap thread.



**LEGACY HD PUMP - GX SERIES**

The most durable pump on the market.



PART NO.	MODEL NO.	GPM	PSI	HP	RPM	SHAFT	WT (LBS.)
<b>GX SERIES: 1/2" INLET X 3/8" OUTLET</b>							
8.921-661.0	<b>S</b> GX5450R	5.4	5000	17.0	1740	24 mm	43
8.921-662.0	GX5450L	5.4	5000	17.0	1740	24 mm	43
<b>GX SERIES: 3/4" BSP INLET X 1/2" BSP OUTLET</b>							
8.920-597.0	<b>S</b> GX9536.2R	9.5	3625	23.6	1740	25 mm	38
8.920-598.0	<b>S</b> GX9536.2L	9.5	3625	23.6	1740	25 mm	38
8.920-599.0	<b>S</b> GX1036.2R	10.4	3625	25.8	1740	25 mm	38
8.920-600.0	GX1036.2L	10.4	3625	25.8	1740	25 mm	38
8.920-602.0	GX1622.2R	15.8	2200	23.8	1740	25 mm	38
8.920-603.0	GX1622.2L	15.8	2200	23.8	1740	25 mm	38
8.752.809.0	GX8043.2	7.9	4350	23.5	1740	25 mm	38



**LEGACY HD PUMP - GM SERIES**



■ Belt Drive

■ 1/2" Inlet x 3/8" Outlet



PART NO.	MODEL NO.	GPM	PSI	HP	RPM	SHAFT	WT (LBS.)
8.751-197.0	<b>S</b> GM3540R.3	3.5	4000	9.5	1850	24 mm	22
8.751-198.0	<b>S</b> GM4030R.3	4	3000	8.2	1000	24 mm	22
8.751-200.0	<b>S</b> GM4035R.3	4.8	3500	7.5	1500	24 mm	22
8.751-201.0	GM4035L.3-Left	4.8	3500	7.5	1500	24 mm	22
8.751-202.0	<b>S</b> GM5030R.3	5.1	3000	13.5	1550	24 mm	22
8.751-203.0	GM5030L.3	5.1	3000	13.5	1550	24 mm	22
8.751-244.0	<b>S</b> GM6035R.3	5.6	3500	13.5	1740	24 mm	22
8.751-245.0	<b>S</b> GM6035L.3	5.6	3500	13.5	1740	24 mm	22

**LEGACY HD PUMP - GT SERIES**



■ Belt Drive

■ 1/2" Inlet x 3/8" Outlet



PART NO.	MODEL NO.	GPM	PSI	HP	RPM	SHAFT	WT (LBS.)
8.921-722.0	GT4540.2R	4.5	4000	12.3	1360	25 mm	39
8.921-723.0	GT4540.2L	4.5	4000	12.3	1360	25 mm	39
8.921-724.0	<b>S</b> GT6036.2R	6.0	3600	14.8	1450	25 mm	39
8.921-725.0	GT6036.2L	6.0	3600	14.8	1450	25 mm	39
8.921-726.0	<b>S</b> GT5636.2R	5.6	3600	13.8	1450	24 mm	39
8.921-727.0	GT5636.2L	5.6	3600	13.8	1450	24 mm	39

**LEGACY PUMP - GBP & GB SERIES**



■ Belt Drive

■ 1/2" Inlet x 3/8" Outlet



PART NO.	MODEL NO.	GPM	PSI	HP	RPM	SHAFT	WT (LBS.)
8.929-708.0	GBP3030R	3.0	3000	6.2	1650	24 mm	14.5
8.929-754.0	GBP3030L	3.0	3000	6.2	1650	24 mm	14.5
8.929-713.0	GBP4025R	4.0	2500	6.8	1550	24 mm	14.5

**LEGACY HD PUMP - READY TO GO SERIES**



■ Belt or Direct Drive

■ Includes a pump, unloader, thermal protector, bypass loop hose, garden hose inlet with filter and quick coupler.



PART NO.	MODEL NO.	DRIVE	GPM	PSI	RPM	SHAFT	UNLOADER
8.924-458.0	GP3035G	Direct	3.0	3500	3400	3/4" Hollow	VRT3
8.924-459.0	GP3535G1	Direct	3.5	3500	3400	1" Hollow	VRT3
8.924-460.0	GS4040G.3	Direct	4.0	4000	3400	1" Hollow	VRT3
8.924-461.0	GB3030R	Belt	3.0	3000	1650	24 mm	VRT3
8.924-462.0	GM3540R.3	Belt	3.5	4000	1850	24 mm	VRT3
8.924-463.0	GM3840R.3	Belt	3.8	4000	1740	24 mm	VRT3



## LEGACY PUMP - HFR SERIES



■ Belt Drive

■ Rated up to 149°F

■ 3/4" Outlet



PART NO.	MODEL NO.	GPM	PSI	HP	RPM	SHAFT	INLET	WT (LBS.)
8.751-677.0	HFR40FR	10.5	4100	28.7	1450	40 mm	1"	106
8.751-678.0	HFR60FR	15.7	4100	43.0	1450	40 mm	1"	106
8.751-680.0	HFR80FL	20.9	4100	57.3	1450	40 mm	1"	106
8.751-681.0	HFR80FR	20.9	4100	57.3	1450	40 mm	1"	106
8.751-689.0	HFR80SR	21.1	2175	30.5	2175	40 mm	1-1/4"	106
8.751-693.0	HFR120SR	31.7	2175	46.1	2175	40 mm	1-1/4"	106

## LEGACY PUMP - HHP SERIES

"Eco brass" pump head: environment-friendly brass alloy with very high mechanical properties equivalent to Stainless-steel 316.



■ Belt Drive

■ Rated up to 149°F

■ 3/4" Inlet x 1/2" Outlet



PART NO.	MODEL NO.	GPM	PSI	HP	RPM	SHAFT	WT (LBS.)
8.751-682.0	HHP25SL	6.6	7250	32.6	1000	40 mm	112
8.751-694.0	HHP4150R	10.8	7250	53.7	1450	40 mm	112

## LEGACY PUMP - NMT SERIES



■ Belt Drive

■ 1/2" Inlet x 3/8" Outlet

■ NMT1520SCWR:  
Rated up to 149°F Nickel Plated

■ NMT2120ESR:  
Rated up to 185°F Stainless-steel - 316L



8.754-110.0

8.754-112.0

PART NO.	MODEL NO.	GPM	PSI	HP	RPM	SHAFT	WT (LBS.)
8.754-110.0	NMT1520SCWR	4.8	3000	9.9	1200	24 mm	21
8.754-112.0	NMT2120ESR	6.6	3000	12.8	1740	24 mm	26

## LEGACY PUMP - NLT SERIES



■ Belt Drive

■ Rated up to 149°F

■ 1/2" Inlet x 3/8" Outlet

■ Double Shaft Pump



PART NO.	MODEL NO.	GPM	PSI	HP	RPM	SHAFT	WT (LBS.)
8.755-731.0	NLT2525S	7.9	3625	19.6	1200	25 mm	41

**LEGACY HD PUMP - GS SERIES**



- Direct Couple-to-gas Engine
- 1/2" Inlet x 3/8" Outlet



PART NO.	MODEL NO.	GPM	PSI	HP	RPM	SHAFT	WT (LBS.)
8.751-205.0	GS3040G.3	3.0	4000	9.0	3400	1" Hollow	24.5
8.751-206.0	<b>S</b> GS3540G.3	3.5	4000	11.0	3400	1" Hollow	23
8.751-207.0	<b>S</b> GS4040G.3	4.0	4000	13.0	3400	1" Hollow	23
8.751-208.0	GS5030G.3	5.0	3000	16.0	3400	1" Hollow	24.5

**LEGACY HD PUMP - GP & GPP SERIES**



- Direct Couple-to-gas Engine
- 1/2" Inlet x 3/8" Outlet



PART NO.	MODEL NO.	GPM	PSI	HP	RPM	SHAFT	WT (LBS.)
8.929-711.0	GPP2535G	2.5	3500	6.0	3400	3/4" Hollow	16.75
8.929-709.0	GPP3035G	3.0	3500	7.2	3400	3/4" Hollow	16.75
8.929-710.0	GPP3035G1	3.0	3500	7.2	3400	1" Hollow	18
8.923-816.0	GP3535G1	3.5	3500	8.4	3400	1" Hollow	18
8.923-817.0	GP4035G1	4.0	3500	9.6	3400	1" Hollow	18

**LEGACY HD PUMP - GF & GFP SERIES**



- Direct Couple-to-electric Motor
- NEMA 56C Frame
- 1/2 - 14 BSPP-F Inlet x 3/8-19 BSPP-F Outlet



PART NO.	MODEL NO.	GPM	PSI	HP	RPM	SHAFT	WT (LBS.)
8.923-818.0	GF2030F	2.1	3000	4.3	3450	5/8" Hollow	17
8.929-707.0	GFP2030S	2.1	3000	4.3	1725	5/8" Hollow	17
8.923-820.0	<b>S</b> GF2830F	2.8	3000	5.8	3450	5/8" Hollow	17
8.929-714.0	GFP2830S	2.8	3000	5.8	1725	5/8" Hollow	17
8.929-712.0	GFP3530F	3.5	3000	7.2	3450	3/4" Hollow	17

**LEGACY HD PUMP - FOG NEMA SERIES**



- Direct Couple-to-electric Motor
- Rated up to 149°F
- 3/8 - 19 BSPP-F Inlet x 3/8-19 BSPP-F Outlet
- NEMA 56C Frame



PART NO.	MODEL NO.	GPM	PSI	HP	RPM	SHAFT	WT (LBS.)
8.754-501.0	FOG1214R	1.2	1450	1.2	1740	5/8" Hollow	12
8.754-502.0	FOG1914R	1.9	1450	1.9	1740	5/8" Hollow	12
8.754-503.0	FOG2514R	2.5	1450	2.5	1740	5/8" Hollow	12

## LEGACY HD PUMP - HY SERIES



- Direct Couple-to-gas Engine
- 1/2" Inlet x 3/8" Outlet
- Ideal for Hydraulic Motors
- Rated up to 149°F



PART NO.	MODEL NO.	GPM	PSI	HP	RPM	SHAFT	WT (LBS.)
8.754-984.0	HY1515HYR	4	2000	5.5	1450	5/8" Hollow	16.75
8.754-985.0	HY1520HYR	4	3000	8.2	1450	5/8" Hollow	16.75

## LEGACY PUMP - TML SERIES



- Belt Drive
- 1/2" Inlet x 3/8" Outlet
- Compare to General Pumps: TS Series  
AR Pumps: RK Series
- Rated up to 149°F
- Industrial Triplex Plunger Pump with  
Al Connecting Rods



PART NO.	MODEL NO.	GPM	PSI	RPM	SHAFT	WT (LBS.)
8.703-382.0	TML-3053	5.3	3000	1450	24 mm	18.9
8.703-457.0	Pump Rail Set (Kit)					

Note: Can be run at 1750 RPM. Please note the pump ships without rails

## LEGACY PUMP - TTV SERIES



- Belt Drive
- 3/4" Inlet x 3/8" Outlet
- Compare to General Pumps: TS Series  
AR Pumps: RK Series
- Rated up to 149°F
- Heavy industrial Triplex Plunger Pump  
with Al Connecting Rods



PART NO.	MODEL NO.	GPM	PSI	RPM	SHAFT	WT (LBS.)
8.703-387.0	TTV-3555	5.5	3500	1450	24 mm	18.9
8.703-388.0	TTV-3563	6.3	3500	1450	24 mm	20

Note: Can be run at 1750 RPM. Please note the pump ships without rails

## LEGACY PUMP - KKV SERIES



- Belt Drive
- 1" Inlet x 1/2" Outlet
- Heavy industrial Triplex Plunger Pump  
with Al Connecting Rods
- Rated up to 149°F



PART NO.	MODEL NO.	GPM	PSI	RPM	SHAFT	WT (LBS.)
8.703-391.0	KKV-3087	8.7	3000	1725	30 mm	39.6

Please note the pump ships without rails

**LEGACY PUMP - WJG SERIES**



- Direct Drive
- Rated up to 149°F
- SAE Flange
- 3/8" Inlet x 3/8" Outlet
- Triplex Plunger Pump with Bronze Connecting Rods
- Compare to General Pumps: TS Series  
AR Pumps: XTV Series



PART NO.	MODEL NO.	GPM	PSI	RPM	SHAFT	WT (LBS.)
8.703-342.0	WJG-2525	2.5	2500	3450	3/4" Hollow	13.2

**LEGACY PUMP - WJH-F & WJH SERIES**



**WJH-F Series**

- Direct Drive
- Rated up to 149°F
- NEMA Flange
- 3/8" Inlet x 3/8" Outlet
- Triplex Plunger Pump with Bronze Connecting Rods
- Compare to General Pumps: TS Series  
AR Pumps: XTV Series

**WJH Series**

- Direct Drive
- Rated up to 149°F
- NEMA Flange
- 3/8" Inlet x 3/8" Outlet
- Triplex Plunger Pump with AI Connecting Rods
- Compare to General Pumps: T and TT Series  
AR Pumps: XTA Series



PART NO.	MODEL NO.	GPM	PSI	RPM	SHAFT	WT (LBS.)
<b>WJH-F SERIES</b>						
8.703-346.0	WJH-2525-F	2.5	2500	3450	5/8" Hollow	13.2
<b>WJH SERIES</b>						
8.703-348.0	WJH-2121	2.1	2100	1725	5/8" Hollow	13.2
8.703-349.0	WJH-2132	3.2	2100	1725	5/8" Hollow	13.2

**LEGACY PUMP - WMG SERIES**



- Direct Drive
- Rated up to 149°F
- SAE Flange
- 1/2" Inlet x 3/8" Outlet
- Triplex Plunger Pump with Bronze Connecting Rods
- Compare to General Pumps: TS Series  
AR Pumps: XMV Series



PART NO.	MODEL NO.	GPM	PSI	RPM	SHAFT	WT (LBS.)
8.703-351.0	WMG-2530	3.0	2500	3450	3/4" Hollow	14.7



## LEGACY PUMP - WMG 1 SERIES



- Direct Drive
- Rated up to 149°F
- SAE Flange
- 1/2" Inlet x 3/8" Outlet
- Premium Triplex Plunger Pump with Bronze Connecting Rods
- Compare to General Pumps: TX Series  
AR Pumps: XMV Series



PART NO.	MODEL NO.	GPM	PSI	RPM	SHAFT	WT (LBS.)
8.703-356.0	WMG-3540	4.0	3500	3450	1" Hollow	14.7

## LEGACY PUMP - TMH SERIES



- Direct Drive
- NEMA Flange
- 1/2" Inlet x 3/8" Outlet
- Rated up to 149°
- Industrial Triplex Plunger Pump with AI Connecting Rods
- Compare to General Pumps: EZ Series  
AR Pumps: RKA Series



PART NO.	MODEL NO.	GPM	PSI	RPM	SHAFT	WT (LBS.)
8.703-375.0	TMH-3035	3.5	3000	1725	1-1/8" Hollow	18.9
8.703-376.0	TMH-3040	4.0	3000	1725	1-1/8" Hollow	18.9
8.703-377.0	TMH-3050	5.0	3000	1725	1-1/8" Hollow	18.9
8.703-378.0	TMH-3055	5.5	3000	1725	1-1/8" Hollow	18.9

## LEGACY PUMP



PART NO.	GPM	PSI	RPM	SHAFT	DESCRIPTION
<b>HORIZONTAL PUMP</b>					
8.920-004.0*	2.6	3000	3400	3/4"	
<b>VERTICAL PUMP</b>					
8.919-886.0	2.6	3000	3400	7/8"	With Garden Hose Fitting Inlet
9.120-020.0	2.6	3000	3400	7/8"	Without Garden Hose Fitting Inlet

\*Note: Can be used to replace Comet pumps listed on page 206.

## PUMP RAILS - LEGACY & LEGACY HD



PART NO.	DESCRIPTION
8.900-757.0	Rails for Models: KKV, TMH, TML, TTV, WJG, WJH, WJH-F, WMG, & WMG-1
8.717-577.0	Rails for Models: FGP, FOG, GF, GB, GBP, GM, GP, GPP, GS, GT, GX, HFR, HHP, HY, NLT, & NMT
9.802-744.0	Mounting Bolts for Models: FGP, FOG, GF, GB, GBP, GM, GP, GPP, GS, GT, GX, HFR, HHP, HY, NLT, & NMT



**LEGACY PUMP REPAIR KIT SELECTION CHART**



PUMP MODEL SERIES	MM	CHECK VALVE KIT	PLUNGER ROD OIL SEAL KIT	WATER SEAL(S) ONLY KIT	WATER SEALS(S) BRASS RING KIT	VALVE CAP KIT	ACCESSORY SEAL KIT
HDL	18	Kit 93	Kit 37	Kit 95	Kit 96	Kit 94	Kit 98
HG	15	Kit 84	Kit 64	Kit 129	Kit 92	Kit 66	N/A
KKV	22	Kit 40	Kit 37	Kit 90	Kit 87	Kit 132	Kit 98
KKV	25	Kit 40	Kit 37	Kit 91	Kit 88	Kit 100	Kit 98
KTV	20	Kit 123	Kit 37	Kit 89	Kit 86	Kit 99	Kit 98
TMG	15	Kit 123	Kit 65	Kit 74	Kit 69	Kit 67	Kit 78
TMH	18	Kit 123	Kit 65	Kit 76	Kit 71	Kit 67	Kit 78
TML	18	Kit 123	Kit 65	Kit 76	Kit 71	Kit 67	Kit 77
TML-F	15	Kit 123	Kit 65	Kit 74	Kit 69	Kit 67	Kit 77
TMS	18	Kit 123	Kit 65	Kit 76	Kit 71	Kit 67	Kit 77
TTV	20	Kit 123	Kit 37	Kit 89	Kit 86	Kit 67	Kit 127
WJG	15	Kit 84	Kit 64	Kit 60	Kit 61	Kit 66	Kit 82
WJH-F	15	Kit 84	Kit 64	Kit 60	Kit 61	Kit 66	Kit 82
WJH	18	Kit 84	Kit 64	Kit 12	Kit 10	Kit 66	Kit 82
WMG-3/4"	15	Kit 124	Kit 64	Kit 73	Kit 68	Kit 67	Kit 80
WMG-1"	15	Kit 124	Kit 64	Kit 73	Kit 68	Kit 67	Kit 79
WMH-F	15	Kit 124	Kit 64	Kit 73	Kit 68	Kit 67	Kit 80
WMH	18	Kit 63	Kit 64	Kit 12	Kit 70	Kit 67	Kit 80
WML	18	Kit 63	Kit 64	Kit 12	Kit 70	Kit 67	Kit 81

**LEGACY PUMP REPAIR TOOL KIT**



9.802-954.0 pump repair tool kit shown.

PART NO.	DESCRIPTION
9.802-954.0	<b>S</b> Legacy Pump Repair Tool Kit (For all models expect GB, GP, GP1, GF)
8.756-590.0	Legacy Pump Repair Tool Kit for Normal Maintenance (For models: GB, GP, GP1 and HY)
8.756-717.0	Legacy Pump Repair Tool Kit for Oil Seal Maintenance (For models: GB, GP, GP1 and HY)

PART NO.	DESCRIPTION
9.802-564.0	Guide, Oil Seal Inserter, Plunger Rod GT-GX-GH
9.802-581.0	Piston, Oil Seal Inserter, Plunger Rod GT-GX-GH
9.802-580.0	Piston, Oil Seal Inserter, Plunger Rod GM-GD-GG-GE-GS
9.802-563.0	Guide, Oil Seal Inserter, Plunger Rod GM-GD-GG-GE-GS
9.802-571.0	Allen Wrench 8 mm, Manifold Bolts GT-GX-GH
9.802-567.0	Allen Wrench 6 mm, Manifold Bolts GM-GD-GG-GE-GS
9.802-570.0	Allen Wrench 5 mm, Crankcase Cover
9.802-565.0	Guide, Oil Seal Inserter, Crankshaft GT-GX-GH
9.802-566.0	Guide, Oil Seal Insert, Crankshaft GM-GD-GG-GE-GS
9.802-568.0	Piston Seal Extractor

PART NO.	DESCRIPTION
9.802-579.0	Piston, Seal Inserter, Manifold GM-GS
9.802-573.0	Guide, Seal Inserter, Manifold GM-GS
9.802-578.0	Piston, Seal Inserter, Manifold GT
9.802-572.0	Guide, Seal Inserter, Manifold GT
8.751-396.0	Guide, Seal Inserter, Manifold GD-GE-GG
8.751-404.0	Guide, Seal Inserter, Manifold GX5050
8.751-397.0	Piston, Seal Inserter, ManifoldGD-GE-GG-GH-GX
8.751-405.0	Guide, Seal Inserter, Manifold GH-GX
9.802-569.0	Hammer, Plastic Head
8.751-403.0	Screwdriver Flathead
9.802-574.0	Box, Plastic Tool Box



**LEGACY PUMP REPAIR KITS**



PART NO.	KIT NO.	DESCRIPTION	NO. OF PIECES	QTY NEEDED PER PUMP
8.703-458.0	Kit 10	WJH Packing / Header / Brass Assy, 18 mm	21	1
8.703-459.0	Kit 12	WM - H&L Packing Kit WJH Packing / Header only, 18 mm	15	1
9.803-041.0	Kit 22	APR.S Unloader Seal(s) Kit	14	1
8.703-461.0	Kit 37	TTV-KTV-HDL Plunger Oil Seal Kit	3	1
8.703-462.0	Kit 40	KKV Check Valves / O-ring Kit	12	1
8.932-979.0	Kit 42	APR.S Unloader Valve Seal Kit	3	1
8.900-701.0	Kit 60	V-Packing, 15 mm Legacy Pump WJH, WJH - F&G Packing / Header only, 15 mm	12	1
8.900-702.0	Kit 61	Complete Plunger Set 15 mm 18 PX WJH - F&G Packing / Header / Brass, 15 mm	18	1
8.703-464.0	Kit 63	WMH&L Check Valve / O-ring Kit	12	1
8.703-465.0	Kit 64	HG / WJ / WM Plunger Oil Seal Kit	3	1
8.703-466.0	Kit 65	TM Plunger Oil Seal Kit	3	1
8.703-467.0	Kit 66	HG / WJ Valve Cap / O-ring, M18 x 1.5 Kit	12	1
8.703-468.0	Kit 67	WM / TM / TTV Valve Cap / O-ring, M27 x 1.5	12	1
8.703-469.0	Kit 68	WM - F&G Packing / Brass Assy Kit, 15 mm	21	1
8.703-470.0	Kit 69	TM - F&G Packing / Brass Assy, 15 mm	21	1
8.703-471.0	Kit 70	WM - H&L Packing / Brass Assy Kit, 18 mm	21	1
8.703-472.0	Kit 71	TM - H&L Packing / Brass Assy Kit, 18 mm	24	1
8.703-456.0	Kit 72	WML Pump Rail Kit (Foot, Spacer, Bolt)	8	1
8.703-474.0	Kit 73	WM - F&G Packing only Kit, 15 mm	15	1
8.703-475.0	Kit 74	TM - F&G Packing only Kit, 15 mm	15	1
8.703-476.0	Kit 76	TM - H&L Packing only Kit, 18 mm	18	1
8.703-479.0	Kit 79	WM-G 1" Accessory Seals Kit	8	1
8.703-483.0	Kit 84	HG / WJ Check Valve / O-ring	12	1
8.703-485.0	Kit 86	TTV-KTV Packing / Brass Assy Kit, 20 mm	24	1
8.703-486.0	Kit 87	KKV Packing / Brass Assy Kit, 22 mm	24	1
8.703-488.0	Kit 89	TTV-KTV Packing only Kit, 20 mm	18	1
8.703-489.0	Kit 90	KKV Packing only Kit L90, 22 mm	18	1
8.703-492.0	Kit 93	HDL Check Valve / O-ring	12	1
8.703-493.0	Kit 94	HDL Valve Containment Kit L94	24	1
8.900-703.0	Kit 95	HDL Packing only Kit L90, 18 mm	18	1
8.703-494.0	Kit 96	HDL Packing / Brass Assy Kit, 18 mm	24	1
8.703-498.0	Kit 123	TM-TTV-KTV Check Valve / O-ring Kit	12	1
8.703-499.0	Kit 124	WM - F&G Check Valve / O-ring Kit	12	1
8.703-501.0	Kit 127	TTV Accessory Oil Seal Kit	10	1
8.703-502.0	Kit 129	HG Packing only Kit, 15 mm	12	1

**ADMIRAL PUMP REPAIR KITS**

For the following Admiral pumps: WE Series, XD Series, XLS Series, CA Series, WG Series, XLE Series, XLG Series, C Series, IB Series.

<b>PART NO.</b>	<b>KIT NO.</b>	<b>DESCRIPTION</b>	<b>QTY NEEDED PER PUMP</b>
8.900-631.0	Kit AP1	Check Valves <i>(for WE, WG, WEL, XL Series, XD Small Brass Head)</i>	1
8.900-632.0	Kit AP2	Brass Valve Covers <i>(for WE, WG, WEL Series and XD Small Brass Head)</i>	1
8.900-633.0	Kit AP4	Oil Seals 15 mm Plunger Rod <i>(for WE, WG and WEL Series)</i>	1
8.900-634.0	Kit AP5	Oil Seals 18 mm Plunger Rod <i>(for XL Series)</i>	1
8.900-636.0	Kit AP7	Male Adapter Rings, 18 mm <i>(for WEL, XLE and XLS Series)</i>	1
8.900-637.0	Kit AP8	V-Packing Seals, 18 mm <i>(for WE and WG Series)</i>	1
8.900-643.0	Kit AP14	Brass Packing Gland, Two Piece, 18 mm <i>(For XLE and XLS Series)</i>	1
8.900-644.0	Kit AP15	V-Packing Seals, Two Piece, 18 mm <i>(for XLE and XLS Series)</i>	1
8.900-645.0	Kit AP16	Super U-Packing Seals, 18 mm <i>(for XLG Series only)</i>	1
8.900-646.0	Kit AP17	Complete Plunger Seal, Two Piece, 18 mm <i>(for XLE and XLS Series)</i>	3
8.900-647.0	Kit AP18	Complete Plunger Seal, Super-U, 18 mm <i>(for XLG Series only)</i>	3
8.900-648.0	Kit AP19	Brass Packing Gland, Super-U, 18 mm <i>(for XLG Series only)</i>	1
8.900-652.0	Kit AP23	Low Pressure Seals, 18 mm <i>(for XL Series)</i>	1
8.900-653.0	Kit AP24	V-Packing Seals, 15 mm, Two Piece <i>(for WE-T and WG-T Series)</i>	1
8.900-654.0	Kit AP25	V-Packing Seals, 18 mm, Two Piece <i>(for WE-T Series only)</i>	1
8.900-657.0	Kit AP28	Complete Plunger Seal, 15 mm, Two Piece <i>(for WE-T and WG-T Series)</i>	3
8.900-666.0	Kit AP38	"Super U" Packing <i>(for XD 20 mm)</i>	1
8.900-676.0	 Kit AP52	Check Valve Assemblies <i>(for IB-1000 Series and CA Series)</i>	1
8.900-680.0	Kit AP57	Male Adapter Rings, 45 mm <i>(for IB-1000 Series C and CA Series)</i>	1
8.900-682.0	Kit AP59	V-Packing Seals, 45 mm <i>(for IB-1000 Series C and CA Series)</i>	1
8.900-683.0	Kit AP61	Glands (45 mm), Brass Packing <i>(for IB-1019, 1032, 1037, C and CA Series)</i>	1

## LEGACY HD PUMP REPAIR KIT SELECTION CHART

FOR 

Use the selection chart below and on the following 2 pages to find the correct and quantity repair kits needed for a specific Legacy HD Pump Model.

PUMP MODEL	SEAL KIT (QTY / PUMP)	COMPLETE SEAL KIT (QTY / PUMP)	CERAMIC PLUNGER KIT (QTY / PUMP)	VALVE KIT (QTY / PUMP)	PLUNGER OIL SEAL KIT (QTY / PUMP)
FOG0614R	N/A	8.754-575.0 (3)	8.754-576.0 (3)	8.754-577.0 (6)	8.754-578.0 (1)
FOG1214R	N/A	8.754-575.0 (3)	8.754-576.0 (3)	8.754-577.0 (6)	8.754-578.0 (1)
FOG1914R	N/A	8.754-575.0 (3)	8.754-576.0 (3)	8.754-577.0 (6)	8.754-578.0 (1)
FOG2514R	N/A	8.754-575.0 (3)	8.754-576.0 (3)	8.754-577.0 (6)	8.754-578.0 (1)
GB3030L	8.754-856.0 (1)	8.758-081.0 (1)	8.754-858.0 (3)	8.754-859.0 (1)	9.803-937.0 (1)
GB3030R	8.754-856.0 (1)	8.758-081.0 (1)	8.754-858.0 (3)	8.754-859.0 (1)	9.803-937.0 (1)
GB4025L	8.754-856.0 (1)	8.758-081.0 (1)	8.754-858.0 (3)	8.754-859.0 (1)	9.803-937.0 (1)
GB4025R	8.754-856.0 (1)	8.758-081.0 (1)	8.754-858.0 (3)	8.754-859.0 (1)	9.803-937.0 (1)
GBP3030R	8.759-015.0 (1)	8.929-348.0 (1)	8.754-858.0 (3)	8.754-859.0 (1)	9.803-937.0 (1)
GBP3030L	8.759-015.0 (1)	8.929-348.0 (1)	8.754-858.0 (3)	8.754-859.0 (1)	9.803-937.0 (1)
GBP4025R	8.759-015.0 (1)	8.929-348.0 (1)	8.754-858.0 (3)	8.754-859.0 (1)	9.803-937.0 (1)
GD3025	8.725-356.0 (1)	8.725-357.0 (3)	9.803-935.0 (3)	9.803-936.0 (1)	9.803-937.0 (1)
GD3030	8.725-354.0 (1)	8.725-355.0 (3)	9.803-934.0 (3)	9.803-936.0 (1)	9.803-937.0 (1)
GD4020.1	8.725-356.0 (1)	8.725-357.0 (3)	9.803-935.0 (3)	9.803-936.0 (1)	9.803-937.0 (1)
GE2020F.1	8.725-354.0 (1)	8.725-355.0 (3)	9.803-934.0 (3)	9.803-936.0 (1)	9.803-937.0 (1)
GE2020S.1	8.725-356.0 (1)	8.725-357.0 (3)	9.803-935.0 (3)	9.803-936.0 (1)	9.803-937.0 (1)
GE2825F.1	8.725-354.0 (1)	8.725-355.0 (3)	9.803-934.0 (3)	9.803-936.0 (1)	9.803-937.0 (1)
GE2825S.1	8.725-356.0 (1)	8.725-357.0 (3)	9.803-935.0 (3)	9.803-936.0 (1)	9.803-937.0 (1)
GE3525F.1	8.725-354.0 (1)	8.725-355.0 (3)	9.803-934.0 (3)	9.803-936.0 (1)	9.803-937.0 (1)
GF2030F	8.754-860.0 (1)	8.725-357.0 (3)	8.754-862.0 (3)	8.754-859.0 (1)	9.803-937.0 (1)
GF2030S	8.754-856.0 (1)	8.725-355.0 (3)	8.754-858.0 (3)	8.754-859.0 (1)	9.803-937.0 (1)
GF2830F	8.754-860.0 (1)	8.758-083.0 (1)	8.754-862.0 (3)	8.754-859.0 (1)	9.803-937.0 (1)
GF2830S	8.754-856.0 (1)	8.758-081.0 (1)	8.754-858.0 (3)	8.754-859.0 (1)	9.803-937.0 (1)
GF3530F	8.754-860.0 (1)	8.758-0830 (1)	8.754-862.0 (3)	8.754-859.0 (1)	9.803-937.0 (1)
GFP2030S	8.759-015.0 (1)	8.929-348.0 (1)	8.754-858.0 (3)	8.754-859.0 (1)	9.803-937.0 (1)
GFP2830S	8.759-015.0 (1)	8.929-348.0 (1)	8.754-858.0 (3)	8.754-859.0 (1)	9.803-937.0 (1)
GFP3530F	8.759-031.0 (1)	8.758-218.0 (1)	8.754-862.0 (3)	8.754-859.0 (1)	9.803-937.0 (1)
GG2530G.1	8.725-354.0 (1)	8.758-081.0 (1)	9.803-934.0 (3)	9.803-936.0 (1)	9.803-937.0 (1)
GG3030G.1	8.725-354.0 (1)	8.758-083.0 (1)	9.803-934.0 (3)	9.803-936.0 (1)	9.803-937.0 (1)
GG3035G1.1	8.725-354.0 (1)	8.725-355.0 (3)	9.803-934.0 (3)	9.803-936.0 (1)	9.803-937.0 (1)
GG4030G1.1	8.725-354.0 (1)	8.725-355.0 (3)	9.803-934.0 (3)	9.802-604.0 (1)	9.802-606.0 (1)
GH5050	9.804-492.0 (1)	9.804-493.0 (3)	9.802-629.0 (3)	9.802-603.0 (1)	9.802-609.0 (1)
GM3540.2	8.725-358.0 (1)	8.758-087.0 (1)	8.933-023.0 (3)	9.802-603.0 (1)	9.802-609.0 (1)
GM3540.3	8.725-358.0 (1)	8.758-087.0 (1)	8.933-023.0 (3)	9.802-603.0 (1)	9.802-609.0 (1)
GM4030.2	8.725-362.0 (1)	8.758-086.0 (1)	9.802-620.0 (3)	9.802-603.0 (1)	9.802-609.0 (1)
GM4030.3	8.725-362.0 (1)	8.758-085.0 (1)	8.751-238.0 (3)	9.802-603.0 (1)	9.802-609.0 (1)
GM4035.2	8.725-360.0 (1)	8.758-085.0 (1)	9.802-629.0 (3)	9.802-603.0 (1)	9.802-609.0 (1)
GM4035.3	8.725-360.0 (1)	8.758-085.0 (1)	8.751-237.0 (3)	9.802-603.0 (1)	9.802-609.0 (1)
GM5030.2	8.725-362.0 (1)	8.758-086.0 (1)	9.802-620.0 (3)	9.802-603.0 (1)	9.802-609.0 (1)
GM6035.2	8.725-360.0 (1)	8.758-085.0 (1)	9.802-629.0 (3)	9.802-603.0 (1)	9.802-609.0 (1)
GM6035.3	8.725-360.0 (1)	8.758-085.0 (1)	8.751-237.0 (3)	9.802-603.0 (1)	9.802-609.0 (1)
GP2535G	8.754-860.0 (1)	8.758-083.0 (1)	8.754-862.0 (3)	8.754-859.0 (1)	9.803-937.0 (1)
GP3035G	8.754-860.0 (1)	8.758-083.0 (1)	8.754-862.0 (3)	8.754-859.0 (1)	9.803-937.0 (1)
GP3035G1	8.754-860.0 (1)	8.758-083.0 (1)	8.754-862.0 (3)	8.754-859.0 (1)	9.803-937.0 (1)

**LEGACY HD PUMP REPAIR KIT SELECTION CHART (CONTINUED)**



Use the selection chart below and on the preceding and following page to find the correct and quantity repair kits needed for a specific Legacy HD Pump Model.

<b>PUMP MODEL</b>	<b>SEAL KIT (QTY / PUMP)</b>	<b>COMPLETE SEAL KIT (QTY / PUMP)</b>	<b>CERAMIC PLUNGER KIT (QTY / PUMP)</b>	<b>VALVE KIT (QTY / PUMP)</b>	<b>PLUNGER OIL SEAL KIT (QTY / PUMP)</b>
GP3535G1	8.754-860.0 (1)	8.758-083.0 (1)	8.754-862.0 (3)	8.754-859.0 (1)	9.803-937.0 (1)
GP4035G1	8.754-860.0 (1)	8.758-083.0 (1)	8.754-862.0 (3)	8.754-859.0 (1)	9.803-937.0 (1)
GPP2535G	8.759-031.0 (1)	8.758-218.0 (1)	8.754-862.0 (3)	8.754-859.0 (1)	9.803-937.0 (1)
GPP3035G	8.759-031.0 (1)	8.758-218.0 (1)	8.754-862.0 (3)	8.754-859.0 (1)	9.803-937.0 (1)
GPP3035G1	8.759-031.0 (1)	8.758-218.0 (1)	8.754-862.0 (3)	8.754-859.0 (1)	9.803-937.0 (1)
GS3040G.2	8.725-358.0 (1)	8.758-087.0 (1)	8.933-023.0 (3)	9.802-603.0 (1)	9.802-609.0 (1)
GS3040G.3	8.725-358.0 (1)	8.758-087.0 (1)	8.933-023.0 (3)	9.802-603.0 (1)	9.802-609.0 (1)
GS3540G.2	8.725-358.0 (1)	8.758-087.0 (1)	8.933-023.0 (3)	9.802-603.0 (1)	9.802-609.0 (1)
GS3540G.3	8.725-358.0 (1)	8.758-087.0 (1)	8.933-023.0 (3)	9.802-603.0 (1)	9.802-609.0 (1)
GS4040G.2	8.725-358.0 (1)	8.758-087.0 (1)	8.933-023.0 (3)	9.802-603.0 (1)	9.802-609.0 (1)
GS4040G.3	8.725-358.0 (1)	8.758-087.0 (1)	8.933-023.0 (3)	9.802-603.0 (1)	9.802-609.0 (1)
GS5030G.2	8.725-358.0 (1)	8.758-087.0 (1)	8.933-023.0 (3)	9.802-603.0 (1)	9.802-609.0 (1)
GS5030G.3	8.725-358.0 (1)	8.758-087.0 (1)	8.933-023.0 (3)	9.802-603.0 (1)	9.802-609.0 (1)
GT4540.2L	8.753-821.0 (1)	8.758-061.0 (1)	8.753-823.0 (3)	8.753-824.0 (1)	9.802-606.0 (1)
GT4540.2R	8.753-821.0 (1)	8.758-061.0 (1)	8.753-823.0 (3)	8.753-824.0 (1)	9.802-606.0 (1)
GT5635.1	8.916-488.0 (1)	8.916-322.0 (3)	9.802-607.0 (3)	9.802-603.0 (1)	9.802-606.0 (1)
GT5636.2L	8.753-821.0 (1)	8.758-061.0 (1)	8.753-823.0 (3)	8.753-824.0 (1)	9.802-606.0 (1)
GT5636.2R	8.753-821.0 (1)	8.758-061.0 (1)	8.753-823.0 (3)	8.753-824.0 (1)	9.802-606.0 (1)
GT6036.2L	8.753-821.0 (1)	8.758-061.0 (1)	8.753-823.0 (3)	8.753-824.0 (1)	9.802-606.0 (1)
GT6036.2R	8.753-821.0 (1)	8.758-061.0 (1)	8.753-823.0 (3)	8.753-824.0 (1)	9.802-606.0 (1)
GX1025.1	8.725-364.0 (1)	8.725-365.0 (3)	9.802-614.0 (3)	9.802-608.0 (1)	9.802-606.0 (1)
GX1036.2L	8.916-487.0(1)	8.757-937.0 (1)	8.752-839.0 (3)	8.753-349.0 (1)	9.802-606.0 (1)
GX1036.2R	8.916-487.0 (1)	8.757-937.0 (1)	8.752-839.0 (3)	8.753-349.0 (1)	9.802-606.0 (1)
GX1225.1	8.725-364.0 (1)	8.725-365.0 (3)	9.802-614.0 (3)	9.802-608.0 (1)	9.802-606.0 (1)
GX1622.2L	8.752-845.0 (1)	8.757-938.0 (1)	8.752-840.0 (3)	8.717-589.0 (1)	9.802-606.0 (1)
GX1622.2R	8.752-845.0 (1)	8.757-937.0 (1)	8.752-840.0 (3)	8.717-589.0 (1)	9.802-606.0 (1)
GX5450L	8.753-512.0 (1)	8.757-939.0 (1)	8.753-514.0 (3)	8.753-515.0 (1)	9.802-606.0 (1)
GX5450R	8.753-512.0 (1)	8.757-939.0 (1)	8.753-514.0 (3)	8.753-515.0 (1)	9.802-606.0 (1)
GX8030.1	8.725-364.0 (1)	8.725-365.0 (3)	9.802-614.0 (3)	9.802-608.0 (1)	9.802-606.0 (1)
GX8043R.2	8.916-488.0 (1)	8.757-936.0 (1)	8.752-838.0 (3)	8.753-349.0 (1)	9.802-606.0 (1)
GX9536.2L	8.916-487.0 (1)	8.757-937.0 (1)	8.752-839.0 (3)	8.753-349.0 (1)	9.802-606.0 (1)
GX9536.2R	8.916-487.0 (1)	8.757-937.0 (1)	8.752-839.0 (3)	8.753-349.0 (1)	9.802-606.0 (1)
HFR105SL	8.754-245.0 (1)	8.754-244.0 (3)	8.754-242.0 (3)	8.754-243.0 (1)	8.754-235.0 (1)
HFR105SR	8.754-245.0 (1)	8.754-244.0 (3)	8.754-242.0 (3)	8.754-243.0 (1)	8.754-235.0 (1)
HFR120SL	8.754-245.0 (1)	8.754-244.0 (3)	8.754-242.0 (3)	8.754-243.0 (1)	8.754-235.0 (1)
HFR120SL	8.754-245.0 (1)	8.754-244.0 (3)	8.754-242.0 (3)	8.754-243.0 (1)	8.754-235.0 (1)
HFR40FL	8.754-231.0 (1)	8.754-232.0 (3)	8.754-233.0 (3)	8.754-243.0 (1)	8.754-235.0 (1)
HFR40FR	8.754-231.0 (1)	8.754-232.0 (3)	8.754-233.0 (3)	8.754-243.0 (1)	8.754-235.0 (1)
HFR40SL	8.754-231.0 (1)	8.754-232.0 (3)	8.754-233.0 (3)	8.754-243.0 (1)	8.754-235.0 (1)
HFR40SR	8.754-231.0 (1)	8.754-232.0 (3)	8.754-233.0 (3)	8.754-243.0 (1)	8.754-235.0 (1)
HFR60FL	8.754-231.0 (1)	8.754-232.0 (3)	8.754-233.0 (3)	8.754-243.0 (1)	8.754-235.0 (1)
HFR60FR	8.754-231.0 (1)	8.754-232.0 (3)	8.754-233.0 (3)	8.754-243.0 (1)	8.754-235.0 (1)
HFR60SL	8.754-231.0 (1)	8.754.232.0 (3)	8.754-233.0 (3)	8.754-243.0 (1)	8.754-235.0 (1)
HFR60SR	8.754-231.0 (1)	8.754-232.0 (3)	8.754-233.0 (3)	8.754-243.0 (1)	8.754-235.0 (1)

**LEGACY HD PUMP REPAIR KIT SELECTION CHART (CONTINUED)**











FOR 

Use the selection chart below and on the preceding 2 pages to find the correct and quantity repair kits needed for a specific Legacy HD Pump Model.

PUMP MODEL	SEAL KIT (QTY / PUMP)	COMPLETE SEAL KIT (QTY / PUMP)	CERAMIC PLUNGER KIT (QTY / PUMP)	VALVE KIT (QTY / PUMP)	PLUNGER OIL SEAL KIT (QTY / PUMP)
HFR80FL	8.754-231.0 (1)	8.754-232.0 (3)	8.754-233.0 (3)	8.754-234.0 (1)	8.754-235.0 (1)
HFR80FR	8.754-231.0 (1)	8.754-232.0 (3)	8.754-233.0 (3)	8.754-234.0 (1)	8.754-235.0 (1)
HFR80SL	8.754-245.0 (1)	8.754-244.0 (3)	8.754-242.0 (3)	8.754-243.0 (1)	8.754-235.0 (1)
HFR80SR	8.754-245.0 (1)	8.754-244.0 (3)	8.754-242.0 (3)	8.754-243.0 (1)	8.754-235.0 (1)
HHP25SL	8.754-236.0 (1)	8.754-237.0 (3)	8.754-246.0 (1)	8.754-241.0 (1)	8.754-235.0 (1)
HHP25SR	8.754-236.0 (1)	8.754-237.0 (3)	8.754-246.0 (1)	8.754-241.0 (1)	8.754-235.0 (1)
HHP2750R	8.754-236.0 (1)	8.754-240.0 (3)	8.754-246.0 (1)	8.754-247.0 (1)	8.754-235.0 (1)
HHP30SL	8.754-236.0 (1)	8.754-237.0 (3)	8.754-246.0 (1)	8.754-241.0 (1)	8.754-235.0 (1)
HHP30SR	8.754-236.0 (1)	8.754-237.0 (3)	8.754-246.0 (1)	8.754-241.0 (1)	8.754-235.0 (1)
HHP3650L	8.754-236.0 (1)	8.754-240.0 (3)	8.754-246.0 (1)	8.754-247.0 (1)	8.754-235.0 (1)
HHP3650R	8.754-236.0 (1)	8.754-240.0 (3)	8.754-246.0 (1)	8.754-247.0 (1)	8.754-235.0 (1)
HHP38FL	8.754-236.0 (1)	8.754-237.0 (3)	8.754-246.0 (1)	8.755-233.0 (1)	8.754-235.0 (1)
HHP38FR	8.754-236.0 (1)	8.754-237.0 (3)	8.754-246.0 (1)	8.755-233.0 (1)	8.754-235.0 (1)
HHP4150L	8.754-236.0 (1)	8.754-240.0 (3)	8.754-246.0 (1)	8.754-247.0 (1)	8.754-235.0 (1)
HHP4150R	8.754-236.0 (1)	8.754-240.0 (3)	8.754-246.0 (1)	8.754-247.0 (1)	8.754-235.0 (1)
HHP5040L	8.754-236.0 (1)	8.754-240.0 (3)	8.754-246.0 (1)	8.754-247.0 (1)	8.754-235.0 (1)
HHP5040R	8.754-236.0 (1)	8.754-240.0 (3)	8.754-246.0 (1)	8.754-247.0 (1)	8.754-235.0 (1)
HHP5750L	8.754-236.0 (1)	8.754-240.0 (3)	8.754-246.0 (1)	8.754-247.0 (1)	8.754-235.0 (1)
HY1515	8.754-980.0 (1)	8.754-981.0 (3)	8.754-983.0 (1)	8.754-577.0 (1)	9.803-937.0 (1)
HY1520	8.754-980.0 (1)	8.754-981.0 (3)	8.754-983.0 (1)	8.754-577.0 (1)	9.803-937.0 (1)
NMT1520CWR	8.754-252.0 (1)	8.754-253.0 (3)	8.754-248.0 (1)	9.802-603.0 (1)	8.754-261.0 (1)
NMT1520SCWR	8.754-252.0 (1)	8.754-253.0 (3)	8.754-248.0 (1)	9.802-603.0 (1)	8.754-261.0 (1)
NMT2120CWR	8.754-252.0 (1)	8.754-253.0 (3)	8.754-248.0 (1)	9.802-603.0 (1)	8.754-261.0 (1)
NMT2120ESR	8.754-239.0 (1)	8.754-229.0 (3)	8.754-256.0 (1)	8.754-230.0 (6)	8.754-261.0 (1)
NLT2525S	8.916-488.0 (1)	8.755-740.0 (3)	8.752-838.0 (3)	8.753-824.0 (1)	9.802-606.0 (1)

**LEGACY HD PUMP REPAIR - SEAL KITS**







FOR 







PART NO.	QTY NEEDED PER PUMP	PART NO.	QTY NEEDED PER PUMP
8.725-354.0	 1	8.754-236.0	1
8.725-356.0	1	8.754-239.0	1
8.725-358.0	 1	8.754-245.0	1
8.725-360.0	 1	8.754-252.0	1
8.725-362.0	 1	8.754-856.0	 1
8.725-364.0	 1	8.754-860.0	 1
8.752-843.0	 1	8.754-980.0	1
8.916-487.0	 1	8.759-015.0	1
8.752-845.0	1	8.759-031.0	1
8.753-512.0	1	8.916-488.0	 1
8.753-821.0	 1	9.804-492.0	1
8.754-231.0	1		



**LEGACY HD PUMP REPAIR - COMPLETE KITS**





FOR 







PART NO.		QTY NEEDED PER PUMP
8.725-355.0		3
8.725-357.0		3
8.725-365.0		3
8.758-061.0		1
8.754.232.0		3
8.754-229.0		3
8.754-237.0		3
8.754-240.0		3
8.754-244.0		3
8.754-253.0		3
8.754-575.0		3
8.754-981.0		3
8.755-740.0		3
8.757-936.0		1
8.757-937.0		1

PART NO.		QTY NEEDED PER PUMP
8.757-938.0		1
8.757-939.0		1
8.758-061.0		1
8.758-081.0		1
8.758-083.0		1
8.758-083.0		1
8.758-085.0		1
8.758-086.0		1
8.758-087.0		1
8.758-218.0		1
8.916-322.0		3
8.929-348.0		1
9.804-493.0		3

**LEGACY HD PUMP REPAIR - CERAMIC PLUNGER KITS**



FOR 





PART NO.		QTY NEEDED PER PUMP
8.751-237.0		3
8.751-238.0		3
8.752-838.0		3
8.752-839.0		3
8.752-840.0		3
8.753-514.0		3
8.753-823.0		3
8.754-233.0		3
8.754-242.0		3
8.754-246.0		1
8.754-248.0		1
8.754-256.0		1

PART NO.		QTY NEEDED PER PUMP
8.754-576.0		3
8.754-858.0		3
8.754-862.0		3
8.754-983.0		3
8.933-023.0		3
9.802-607.0		3
9.802-614.0		3
9.802-620.0		3
9.802-629.0		3
9.803-934.0		3
9.803-935.0		3

**LEGACY HD PUMP REPAIR - VALVE KITS**

FOR 

PART NO.		QTY NEEDED PER PUMP
8.717-589.0		1
8.753-349.0		1
8.753-515.0		1
8.753-824.0		1
8.754-230.0		6
8.754-234.0		1
8.754-241.0		1
8.754-243.0		1

PART NO.		QTY NEEDED PER PUMP
8.754-247.0		1
9.802-603.0		1
8.754-577.0		1
8.754-859.0		1
9.802-603.0		1
9.802-604.0		1
9.802-608.0		1
9.803-936.0		1



**LEGACY HD PUMP REPAIR - PLUNGER OIL SEAL KITS**

FOR **Legacy HD**

PART NO.	QTY NEEDED PER PUMP
8.752-835.0	1
9.802-606.0	1
8.754-235.0	1
8.754-261.0	1

PART NO.	QTY NEEDED PER PUMP
8.754-578.0	1
9.802-606.0	1
9.802-609.0	1
9.803-937.0	1



**INTERPUMP / GENERAL PUMP - SOLID-SHAFT PUMPS**



8.702-629.0



8.702-635.0



8.702-703.0

PART NO.	MODEL NO.	INTERPUMP MODEL NO.	GP MODEL NO.	GPM	PSI	RPM	SHAFT DIA
8.753-482.0			TSS1021	5.6	1700	1450	24 mm
8.702-629.0	102048	WS92	TS921	5.9	1800	1450	24 mm
9.802-358.0	102052	W99	T991	3.5	1500	1450	24 mm
8.702-625.0	102046	W92	T921	5.0	1700	1050	24 mm
8.702-622.0	102042	WS82	TS821	5.6	1500	1450	24 mm
8.702-636.0	102058	WS101	TS1011	4.0	2000	1450	24 mm
8.702-635.0	102056	W101	T1011	4.5	2000	1125	24 mm
8.702-646.0	102076	WS133	TS1331	3.5	2100	1450	24 mm
8.702-645.0	102074	WS132	TS1321	4.75	2100	1450	24 mm
8.702-643.0	102072	W132	T1321	5.5	2100	1150	24 mm
8.702-650.0	102084	WS151	TSS1511s	4.0	3500	1450	24 mm
8.702-649.0	102082	W151	T1511	4.5	2500	1125	24 mm
8.702-654.0	102088	W162	T1621	5.0	2500	1050	24 mm
8.702-665.0	102105	W201	T2011	4.5	3000	1125	24 mm
8.702-667.0	102110	WS201	TS2011	4.0	3000	1450	24 mm
8.702-670.0	102115G	WS202	TS2021	4.5	3500	1125	24 mm
8.702-701.0	102170	W995	T9951	3.4	1300	1750	24 mm
8.702-702.0	102174	W996	T9961	4.0	1100	1750	24 mm
8.702-703.0	102176	W997	T9971	4.0	2000	1750	24 mm
8.702-686.0	102135	W912	T9121	4.75	1500	1750	24 mm
8.702-687.0	102140	W913	T9131	4.0	1900	1750	24 mm
8.702-690.0	102150	W921	T9211	4.0	2900	1750	24 mm
8.702-693.0	102152	W928	T9281	4.0	4000	1750	24 mm
8.702-695.0	102154	T5050	T5050	5.0	5000	1845	24 mm
8.702-661.0	102097	-	TT9111	3.0	1500	1750	24 mm
8.702-630.0	102049	WW93	TT931	2.9	1500	2800	24 mm
8.702-628.0	102047	WW94	TT941	3.43	1300	2800	24 mm
8.702-685.0	102134	WW935	TT9351	3.5	2500	3400	24 mm
8.702-663.0	102102	WW944	TT9441	4.4	2500	3400	24 mm

\*Duplex Pump

**INTERPUMP / GENERAL PUMP - TX SOLID-SHAFT PUMP**



PART NO.	MODEL NO.	GPM	PSI	RPM	SHAFT DIA
8.702-741.0	TX1510S34	4.0	3000	3400	24 mm

**INTERPUMP / GENERAL PUMP - SERIES "44" (EZ SERIES) SOLID-SHAFT PUMP**



PART NO.	INTERPUMP MODEL NO.	GP MODEL NO.	GPM	PSI	RPM	SHAFT DIA
8.702-766.0	W956	EZ2536S	3.6	2500	1750	24 mm
8.702-768.0	W959	EZ2542S	4.2	2500	1750	24 mm
8.702-773.0	W186	EZ3040S	4.0	3000	3400	24 mm
8.702-782.0	-	EZ4040S34	4.0	4000	3400	24 mm

Note: For Direct-Drive Mounting see flanges on page 210

**INTERPUMP / GENERAL PUMP - TSF SOLID-SHAFT PUMP**



PART NO.	MODEL NO.	GPM	PSI	RPM	SHAFT DIA
8.702-740.0	TSF2021	7.0	3600	1450	24 mm
8.702-736.0	TSF2221	10.2	3000	1750	24 mm
8.702-737.0	TSF2421	12.0	2500	1750	24 mm

**INTERPUMP / GENERAL PUMP - LARGE FRAME SOLID-SHAFT PUMP**



PART NO.	INTERPUMP MODEL NO.	GP MODEL NO.	GPM	PSI	RPM	SHAFT DIA
8.702-612.0	W4A	T41A	12.0	900	650	35 mm
8.702-640.0	WS104	TS1041	8.0	1600	1450	35 mm
8.702-652.0	WS153	TS1531	8.0	2175	1450	35 mm
8.702-672.0	W203	T2031	9.0	3000	1140	32 mm
<b>DOUBLE HEADED PUMPS</b>						
8.702-648.0	WS135	TS1351	11.0	2000	1450	32 mm
8.702-657.0	W163	T1631	10.0	2500	1080	32 mm

**INTERPUMP / GENERAL PUMP - CAR WASH SOLID-SHAFT PUMP**



PART NO.	MODEL NO.	GPM	PSI	RPM	SHAFT DIA	SHIP WT
8.702-754.0	CW2040	5.0	2500	1250	24 mm	30 lbs.
8.702-745.0	CW3040	5.0	3000	1250	24 mm	32 lbs.
9.107-630.0	HTCK3623S	21.0	1500	1150	30 mm	80 lbs.



## INTERPUMP / GENERAL PUMP - HOLLOW-SHAFT



■ Direct Drive



8.702-711.0



8.702-708.0

■ Flanged for direct couple to gasoline or electric motors

PART NO.	INTERPUMP MODEL NO.	GP MODEL NO.	GPM	PSI	RPM	SHAFT DIA
<b>COUPLE TO GASOLINE MOTORS</b>						
8.702-711.0	WW906G	TT9061G	2.1	1400	3400	3/4"
8.702-682.0		TT1540GBF	4.0	1500	3400	3/4"
8.702-673.0		TT2028GBF	2.8	2000	3400	3/4"
8.702-674.0		TT2035GBF	3.5	2000	3400	3/4"
<b>COUPLE TO ELECTRIC MOTORS</b>						
8.702-708.0	W905E	T9051E	2.1	1400	1750	5/8"
8.702-710.0	WW906E	TT9061E	2.1	1400	3400	5/8"
8.702-713.0	WW907E	TT9071E	2.8	1500	3400	5/8"
8.702-677.0	-	TT9111EBF	3.0	1500	1750	5/8"
8.702-679.0	-	TT2021EBF	2.1	2000	3400	5/8"
8.702-680.0	-	TT2028EBF	2.8	2000	3400	5/8"
8.702-681.0	-	TT2035EBF	3.5	2000	3400	3/4"

## INTERPUMP / GENERAL PUMP - EZ SERIES HOLLOW-SHAFT



■ Direct Drive



■ Flanged for direct couple to gasoline or electric motors

PART NO.	INTERPUMP MODEL NO.	GP MODEL NO.	GPM	PSI	RPM	SHAFT DIA
<b>COUPLE TO GASOLINE MOTORS</b>						
8.702-764.0	WW961EZG	EZ3040G	4.0	2500	3400	1"
8.702-776.0	-	EZ4030G34	3.0	4000	3400	1"
8.702-778.0	-	EZ4035G34	3.5	4000	3400	1"
8.702-779.0	-	EZ4040G34	4.0	4000	3400	1"
<b>COUPLE TO ELECTRIC MOTORS</b>						
8.702-758.0	W956EZE	EZ2536E	3.6	2500	1750	1-1/8"
8.702-759.0	W959EZE	EZ2542E	4.2	2500	1750	1-1/8"
8.702-761.0	W950EZE	EZ2545E	2.5	2500	1750	1-1/8"
8.702-760.0	W953EZE	EZ2555E	5.5	2500	3400	1-1/8"
8.702-780.0	-	EZ4035E	3.5	4000	3400	1-1/8"

## INTERPUMP / GENERAL PUMP - TX SERIES HOLLOW-SHAFT



■ Direct Drive



■ Flanged for direct couple to 184TC electric motor

PART NO.	MODEL NO.	GPM	PSI	RPM	SHAFT DIA	SHIP WT
8.702-784.0	TX1810E179	3.2	2000	1750	1-1/8"	30 lbs.
8.702-785.0	TX1812E179	3.8	2000	1750	1-1/8"	32 lbs.

**INTERPUMP / GENERAL PUMP KIT SELECTION CHART**

Use the selection chart below to find the correct repair kit for the specific Interpump / General Pump model.



PUMP MODEL	VALVES	OIL SEAL PISTON	PACKINGS	PACKINGS WITH BRASS	CERAMIC	VALVE CAPS	PISTON	BOLTS HEAD RINGS	CRANK OIL SEAL
<b>TX1510S34</b>	Kit 123	Kit 159	Kit 160	Kit 166	104800	Kit 124	52040009	-	-
<b>TX1810E179</b>	Kit 123	Kit 159	Kit 161	Kit 167	104804	Kit 124	52040009	-	-
<b>TX1812E179</b>	Kit 123	Kit 159	Kit 161	Kit 167	104804	Kit 124	52040009	-	-
<b>TSF2021</b>	Kit 169	Kit 2	Kit 170	Kit 171	083900	66130041	66040109	-	Kit 3
<b>TSF2221</b>	Kit 169	Kit 2	Kit 172	Kit 173	107921	66130041	66040109	-	Kit 3
<b>TSF2421</b>	Kit 169	Kit 2	Kit 181	Kit 182	107923	66130041	66040409	-	Kit 3
<b>T9721</b>	Kit 1	Kit 23	Kit 19	Kit 27	104809	Kit 4	Kit 6	Kit 21	104641
<b>T9731</b>	Kit 1	Kit 23	Kit 19	Kit 27	104809	Kit 4	Kit 6	Kit 21	104637
<b>T731</b>	Kit 1	Kit 23	Kit 19	Kit 27	104809	Kit 4	Kit 6	Kit 21	104641
<b>T991</b>	Kit 1	Kit 23	Kit 19	Kit 27	104809	Kit 4	Kit 6	Kit 21	104641
<b>T9951</b>	Kit 1	Kit 23	Kit 19	Kit 27	104809	Kit 4	Kit 6	Kit 21	104641
<b>T9971</b>	Kit 1	Kit 23	Kit 19	Kit 27	104809	Kit 4	Kit 6	Kit 21	104641
<b>T921</b>	Kit 1	Kit 2	Kit 148	Kit 29	104805	Kit 4	Kit 6	Kit 11	Kit 3
<b>T1011</b>	Kit 1	Kit 2	Kit 69	Kit 28	104803	Kit 4	Kit 6	Kit 7	Kit 3
<b>T1321</b>	Kit 1	Kit 2	Kit 148	Kit 29	104805	Kit 4	Kit 6	Kit 11	Kit 3
<b>T9211</b>	Kit 1	Kit 2	Kit 69	Kit 28	104803	Kit 4	Kit 6	Kit 7	Kit 3
<b>T9281</b>	Kit 1	Kit 2	Kit 109	Kit 112	104808	Kit 106	Kit 107	Kit 108	Kit 3
<b>T4251</b>	Kit 122	Kit 44	Kit 77	Kit 78	104810	Kit 122	-	Kit 7	Kit 32
<b>T5050</b>	Kit 150	Kit 2	Kit 109	Kit 151	104808	Kit 150	47040856	Kit 108	Kit 3
<b>TS1021</b>	Kit 1	Kit 2	Kit 69	Kit 28	104803	Kit 4	Kit 6	Kit 7	Kit 3
<b>TS1011</b>	Kit 1	Kit 2	Kit 69	Kit 28	104808	Kit 4	Kit 6	Kit 7	Kit 3
<b>TS1041</b>	Kit 62	Kit 37	Kit 69	Kit 82	104803	98231200	Kit 54	Kit 7	Kit 32
<b>TS1321</b>	Kit 1	Kit 2	Kit 148	Kit 29	104805	Kit 4	Kit 6	Kit 11	Kit 3
<b>TS1511</b>	Kit 1	Kit 2	Kit 69	Kit 28	104803	Kit 4	Kit 6	Kit 7	Kit 3
<b>TS1531</b>	Kit 62	Kit 37	Kit 69	Kit 82	104803	98231200	Kit 54	Kit 7	Kit 32
<b>TS2011</b>	Kit 1	Kit 2	Kit 69	Kit 28	104803	Kit 5	Kit 6	Kit 7	Kit 3
<b>TS2021</b>	Kit 1	Kit 2	Kit 69	Kit 28	104803	Kit 5	Kit 6	Kit 7	Kit 3
<b>TT9111</b>	Kit 1	Kit 83	Kit 141	Kit 140	104806	Kit 84	51040109	-	104641
<b>TT941</b>	Kit 1	Kit 83	Kit 97	Kit 96	083807	Kit 84	51040109	-	104641
<b>TT9441</b>	Kit 1	Kit 23	Kit 88	Kit 92	104800	Kit 4	Kit 6	-	104641
<b>TT2028</b>	Kit 1	Kit 83	Kit 97	Kit 96	083807	Kit 84	-	-	104637
<b>TT2035</b>	Kit 1	Kit 83	Kit 97	Kit 96	083807	Kit 84	-	-	104637
<b>TT9061</b>	Kit 1	Kit 83	Kit 97	Kit 96	083807	Kit 84	-	-	104637
<b>TT9071</b>	Kit 1	Kit 83	Kit 97	Kit 96	083807	Kit 84	-	-	104637
<b>EZ2542E</b>	Kit 123	Kit 23	Kit 127	Kit 131	104804	Kit 124	-	Kit 129	104649
<b>EZ2545E</b>	Kit 123	Kit 23	Kit 88	Kit 130	14800	Kit 124	-	Kit 90	104649
<b>EZ3035G</b>	Kit 123	Kit 23	Kit 88	Kit 130	104800	Kit 124	52040009	Kit 90	104649
<b>EZ3040G</b>	Kit 123	Kit 23	Kit 88	Kit 130	104800	Kit 124	52040009	Kit 90	104649
<b>EZ3040S</b>	Kit 123	Kit 23	Kit 88	Kit 130	104800	Kit 124	52040009	Kit 90	104644
<b>T9051EBF</b>	Kit 1	Kit 83	Kit 97	Kit 96	104800	Kit 84	51040009	-	104644
<b>EZ2542S</b>	Kit 123	Kit 23	Kit 127	Kit 131	104804	Kit 124	44040109	Kit 129	104644
<b>EZ3042S</b>	Kit 123	Kit 23	Kit 127	Kit 131	104804	Kit 124	44040109	Kit 129	104644
<b>ES4040S34</b>	Kit 123	Kit 23	Kit 153	Kit 156	104812	Kit 124	44040266	Kit 155	104644
<b>EZ3030G34</b>	Kit 123	Kit 23	Kit 88	Kit 130	104800	Kit 124	52040009	Kit 90	104649
<b>EZ3045G</b>	Kit 123	Kit 23	Kit 88	Kit 130	104800	Kit 124	52040009	Kit 90	104649
<b>EZ4035G34</b>	Kit 123	Kit 23	Kit 153	Kit 156	104812	Kit 124	44040266	Kit 155	104649
<b>TS1331-B</b>	Kit 1	Kit 2	Kit 69	Kit 28	104803	Kit 4	Kit 6	Kit 7	Kit 3
<b>T1631</b>	Kit 1	Kit 24	Kit 148	Kit 28	104805	Kit 4	Kit 6	Kit 11	-
<b>CW1012</b>	Kit 62	Kit 37	Kit 113	Kit 67	104813	-	Kit 74	Kit 65	Kit 32



**INTERPUMP / GENERAL PUMP KITS - GENUINE**

We stock a complete selection of original Interpump / General Pump repair kits. See previous page for our kit selection chart.



■ Complete selection of repair kits

PART NO.	KIT.	DESCRIPTION
8.702-798.0	1	Valve
8.702-800.0	2	Piston, Rod Oil Seal
8.702-801.0	<b>S</b> 3	Crankshaft Oil Seal
8.702-802.0	4	Valve Cap
8.702-803.0	5	Valve Cap
8.702-805.0	<b>S</b> 6	Piston Bolt
8.702-804.0	6A	Washer for Piston Bolts
8.702-806.0	7	Head Ring
8.702-116.0	8	HP Old Style, 20 mm Packing
8.702-115.0	<b>S</b> 8	New Style
8.900-442.0	8	Old Style, Packing Kit
8.900-444.0	9	Packing Spacer
8.702-809.0	10	Retainer, 20 mm Packing
8.702-810.0	11	22 mm Head Ring
8.702-811.0	12	22 mm Packing
8.702-813.0	15	Packing Adapter
8.702-814.0	16	24 mm Packing
8.702-817.0	19	20 mm HP Packing
8.702-818.0	19	New Style
8.702-820.0	20	20 mm, Intermed. Ring
8.702-821.0	21	20 mm Head Ring
8.702-823.0	23	Piston, Rod Oil Seal
8.702-824.0	24	Piston, Rod Oil Seal
8.702-826.0	27	20 mm, Packing Assy
8.702-829.0	28	20 mm, Packing Assy
8.702-830.0	<b>S</b> 29	22 mm, Packing Assy
8.702-833.0	32	Crankshaft, Oil Seal
8.702-834.0	37	Piston, Rod Oil Seal
8.702-836.0	38	36 mm Packing
8.702-847.0	58	K5 Maintenance
8.702-849.0	60	K5, Complete Rebuild
8.702-851.0	62	Valve
8.702-853.0	64	Packing w/ Intermed. Rings
8.702-854.0	65	30 mm, Head Ring
9.107-628.0	967	30 mm Packing Assy
8.702-857.0	69	20 mm Packing with Restop
8.702-858.0	70	K7 Maintenance
8.702-859.0	71	Intermed Ring with Restop
8.702-860.0	72	Maintenance Kit
8.702-864.0	77	20 mm Packing with Restop
8.702-872.0	83	Oil Seal
8.702-873.0	84	Valve Cap
8.702-874.0	85	Complete Packing
8.702-875.0	86	Packing Retainer

PART NO.	KIT.	DESCRIPTION
8.702-877.0	88	Packing, EZ3040G
8.702-879.0	90	Head Ring
8.702-882.0	92	Piston Seal
8.702-883.0	93	Control Set W2
8.702-886.0	96	Packing Assy
8.702-887.0	97	Packing
8.702-893.0	102	Unloader Maintenance
8.702-897.0	106	Valve Cap
8.702-898.0	107	Piston Bolt, Pump T9281
8.702-899.0	108	Head Ring for T-9281
8.702-900.0	109	16 mm, Intermed Ring
8.702-901.0	110	16 mm, Intermed Ring
8.702-902.0	111	Packing, Retainer, 16 mm, Pump T9281
8.702-903.0	112	16 mm, Packing Assy
8.702-904.0	113	Packing Assy
8.702-908.0	118	Packing
8.702-909.0	119	Packing
8.702-912.0	122	Valves
8.702-913.0	<b>S</b> 123	Valve, EZ3040
8.702-914.0	124	Valve Cap and O-Ring for EZ Pump
8.702-917.0	127	Packing, EZ2542S
8.702-919.0	129	Head Ring, EZ Series
8.702-920.0	130	Packing Complete
8.702-921.0	131	EZ Pump
8.702-928.0	140	Packing Assy, T9111
8.702-929.0	141	General
8.702-930.0	148	22 mm Packing
8.702-932.0	150	Valve, General T5050
8.702-933.0	151	Packing Retainer
8.702-934.0	153	Packing Kit
8.702-936.0	156	13 mm Packing
8.702-937.0	159	Oil Seal
8.702-938.0	160	Short Packing
8.702-939.0	161	Packings
9.841-673.0	163	Seal Retainer
9.841-638.0	165	Int Ring
8.702-942.0	166	Long Kit 1
8.702-943.0	167	Packing Assy
8.702-945.0	<b>S</b> 169	Valve Kit
8.702-946.0	170	LP Seal Kit and HP Seal
8.702-947.0	<b>S</b> 171	Packings
8.702-948.0	172	Low / High Packing
8.702-949.0	173	Packings, Kit 176 & Kit 180



**INTERPUMP / GENERAL PUMP KITS - GENUINE (CONTINUED)**



PART NO.	KIT.	DESCRIPTION
8.702-950.0	174	Seal Kit
8.702-951.0	175	16MM Seal Kit
8.702-952.0	176	18 mm Packing
8.702-953.0	180	18 mm Packing
8.702-954.0	181	LP Seal Kit and HP Seal
8.702-955.0	182	Packings, Kit 196 & Kit 197
8.702-956.0	196	15 mm HP Packing
8.702-957.0	197	18 mm HP Packing

PART NO.	KIT.	DESCRIPTION
8.702-958.0	201	Valve kit
8.702-959.0	202	Packing Kit
8.723-898.0	203	Seals
8.702-960.0	204	Seals
8.723-512.0	212	Kit 212
8.702-962.0	226	15 mm Packing
8.702-961.0	220	Hot Seals & Valves

**CERAMIC PLUNGERS**



- Precision-ground, high-polish, solid ceramic plungers, designed for long life even under constant use.

PART NO.	GENERAL PUMP PART NO.	SIZE
8.703-185.0	51040109	18 mm
8.703-187.0	52040009	15 mm, EZ Series
8.703-188.0	46040009	For W50 Pump
8.703-190.0 <b>S</b>	47040409	20 mm
8.703-191.0	44040109	18 mm, EZ Series
8.703-192.0	47040509	22 mm
8.900-575.0	51040166	18 mm, TP Series
8.703-193.0	47040609	24 mm Solid, Ceramic
8.703-194.0	47040856	16 mm, 47 Series
8.703-195.0	50040409	20 mm, T Series 49
8.703-196.0	61040056	20 mm, 76 & 77 Series
8.703-198.0	44040266	13 mm, EZ Series
8.703-200.0	76040209	45 mm
8.703-767.0	66040109	22 mm, TSF2221
8.703-768.0	66040409	24 mm
8.701-400.0	51040009	15 mm, T21

## AR TRIPLEX CERAMIC PLUNGER PUMPS



■ Direct Drive



8.702-498.0



8.702-513.0



8.702-550.0

PART NO.	MODEL NO.	GPM	PSI	RPM	SHAFT DIA	SHIP WT
<b>GAS ENGINE FLANGED MODELS</b>						
8.702-494.0	XTV3G22D-F7	3.0	2200	3400	3/4"	11 lbs.
8.702-498.0	XMV3G30D-F24	3.0	3000	3400	1"	19 lbs.
8.702-495.0	XMV3G25D-F25	3.0	2500	3400	3/4"	19 lbs.
8.702-542.0	XMV35G25D-F25	3.5	2500	3400	3/4"	19 lbs.
8.702-602.0	RKV4G37D-F24	4.0	3700	3400	1"	21 lbs.
8.702-582.0	RKV4G40HD-F24	4.0	4000	3400	1"	21 lbs.
9.108-219.0	RMV2.5G30	2.5	3000	3400	3.4"	7.5 lbs.
<b>SOLID-SHAFT MODELS</b>						
8.702-506.0	XTA3G22N	3.0	2200	1750	24 mm	11 lbs.
8.715-307.0	XMA3.5G25N	3.5	2500	1750	24 mm	18 lbs.
8.702-593.0	RKA4G30N	4.0	3000	1750	24 mm	19 lbs.
8.702-597.0	RKA4G40HN	4.0	4000	1750	24 mm	21 lbs.
8.702-513.0	XW2623	6.87	3400	1450	24 mm	34 lbs.
<b>ELECTRIC FLANGED MODELS</b>						
8.702-550.0	XTV2G15EBA-F8	2.1	1500	3400	5/8"	10 lbs.
8.702-551.0	XTV3G16E-F8	3.0	1600	3400	5/8"	10 lbs.
8.702-500.0	XTV3G22E-F8	3.0	2200	3400	5/8"	11 lbs.
8.702-515.0	XTA3G22E-F8	3.0	2200	1750	5/8"	11 lbs.
8.702-514.0	XTA3G16EBA-F8	3.0	1600	1750	5/8"	10 lbs.
8.702-591.0	RKA4G20E-F17	4.0	2000	1750	1-1/8"	21 lbs.
8.702-592.0	RKA4G30E-F17	4.0	3000	1750	1-1/8"	21 lbs.

**AR DIRECT DRIVE PUMPS**



**9.113-119.0**



**9.113-106.0**



**9.113-103.0**

PART NO.	MODEL NO.	GPM	PSI	RPM	SHAFT DIA	SHIP WT
<b>DIRECT DRIVE GAS PUMPS</b>						
9.113-101.0	RCV3G27D-F7	3.0	2700	3400	3/4"	11 lbs.
9.113-102.0	RCVU3G27D-F7-EZ	3.0	2700	3400	3/4"	11 lbs.
9.113-116.0	RCV25G27D-F7	2.5	2700	3400	3/4"	11 lbs.
9.113-118.0	RCV35G25D-F8	5.0	2500	3400	5/8"	11 lbs.
9.113-119.0	RCV3G27D-VR54-PKG	3.0	2700	3400	1"	11 lbs.
9.113-121.0	RKV35G40HD-F24	3.5	4000	3400	1"	21 lbs.
9.113-122.0	RKV45G40HD-F24	4.5	4000	3400	1"	21 lbs.
9.113-123.0	RKV5G40HD-F24	5.0	4000	3400	1"	21 lbs.
<b>DIRECT DRIVE ELECTRIC PUMPS</b>						
9.113-106.0	RK1828HN	4.75	4000	1450	24 mm	20 lbs.
9.113-111.0	RCA2G22E-F8	2.0	2200	1750	5/8"	11 lbs.
9.113-112.0	RCA35G16E-F8	3.5	1600	1750	5/8"	11 lbs.
9.113-114.0	RCA3G25E-F8	3.0	2500	1750	24 mm	11 lbs.
9.113-117.0	RCV2G25E-F8	2.0	2500	3400	5/8"	11 lbs.
9.113-124.0	RRA35G30E-F17	3.5	3000	1750	1-1/8"	18 lbs.
9.113-125.0	RRA3G30E-F17	3.0	1700	1750	1-1/8"	18 lbs.
<b>COMMERICAL PUMPS</b>						
9.113-103.0	RG1528HN	4.0	4000	1450	24 mm	27.5 lbs.
9.113-104.0	RG2125HN	5.5	3650	1450	24 mm	27.5 lbs.
9.113-105.0	RK1528HN	4.0	4000	1450	24 mm	20 lbs.
9.113-107.0	RKA4G40HN-CR	4.0	4000	1750	24 mm	20 lbs.
9.113-108.0	RRA55G26E-F17	5.5	3000	1750	1-1/8"	18 lbs.
9.113-109.0	RRV4G40-VRT-PKG	4.0	3600	3400	1"	20 lbs.
9.113-110.0	XWL50.20NB	13.0	3000	1450	22 mm	34 lbs.
9.113-113.0	RCA35G25N	3.5	2500	1750	24 mm	10 lbs.
9.113-115.0	RCA3G25N	3.0	2500	1750	24 mm	10 lbs.
9.113-120.0	RKA35G40HN	3.5	4000	1750	24 mm	20 lbs.
9.113-126.0	RRA4G40N	4.0	4000	1750	24 mm	17 lbs.
9.113-127.0	RRA55G30N	5.5	3000	1750	24 mm	17 lbs.
9.113-129.0	RRV35G40HD-F24	3.5	4000	3400	1"	18 lbs.
9.113-130.0	RRV3G36D-F24	3.0	3600	3400	1"	18 lbs.

## AR PUMP REPAIR KIT SELECTION CHART

Use the following chart to find AR Repair Kits by pump model number. See next page for AR kit part numbers. We also stock a broad selection of non-kit AR repair parts.



PUMP MODEL	WATER SEALS	CHECK VALVES	OIL SEALS	PISTON KIT	PISTON GUIDE	SUPPORT RINGS	HOT KIT
<b>XJV</b>	AR002798	AR002869	AR002797	AR002596	AR1980180 ea	AR1980190 ea	-
<b>XJW</b>	AR002800	AR002869	AR002797	AR002596	AR1980180 ea	AR1980190 ea	-
<b>XT-15MM</b>	AR001866	AR001864	AR001872-N ver AR002725-H/D	AR002628	AR1260151 ea	AR1520120 ea	AR002815
<b>XT-18MM</b>	AR001874	AR001864	AR001872-N ver AR002726-H/D	AR002629	AR1260450 ea	AR1320340 ea	AR002816
<b>XTA-15MM</b>	AR001866	AR001864	AR001860-E ver	AR002628	AR1260151 ea	AR1520120 ea	AR002815
<b>XTA-18MM</b>	AR001874	AR001864	AR001860-E ver	AR002629	AR1260450 ea	AR1320340 ea	AR002816
<b>XTV</b>	AR002520	AR001864	AR001860-D, E ver AR001872-N ver	AR002628	AR1260151 ea	AR1520120 ea	AR002815
<b>XM-15MM</b>	AR002741	AR001864	AR002786-N ver AR1780100 ea R	AR002544	AR1780090 ea F	AR002740	AR002030-V
<b>XM-18MM</b>	AR002747	AR001864	AR002786-N ver AR1780120 ea R	AR002545	AR1780110 ea F	AR002745	AR002029-V
<b>XMA-15MM</b>	AR002741	AR001864	AR002786-N ver AR1780100 ea R	AR002544	AR1780090 ea F	AR002740	AR02776
<b>XMA-18MM</b>	AR002747	AR001864 AR002787-E ver	AR002786-N ver AR1780120 ea R	AR002545	AR1780110 ea F	AR002745	AR002777
<b>XMV</b>	AR002741	AR001864 AR002787-D ver	AR002786-N ver AR1780100 ea R	AR002544	AR1780090 ea F	AR002740	AR02817
<b>XRC-18MM</b>	AR001857	AR002864	AR001855-N ver	AR002546	AR1380090 ea	AR001829	AR002819
<b>XRC-20MM</b>	AR001887	AR002864	AR001855-N ver	AR002547	AR1380150 ea	AR001815	AR002820
<b>XRCA-18MM</b>	AR001857	AR002864	AR001855-N ver	AR002546	AR1380090 ea	AR001829	AR002819
<b>XRCA-20MM</b>	AR001887	AR002864	AR001855-N ver AR001856-E ver	AR002547	AR1380150 ea	AR001815	AR002820
<b>XRCV</b>	AR001857	AR001828	AR001856-D, E ver	AR002546	AR1380090 ea	AR001829	AR002819
<b>RK-18MM</b>	AR001857	AR002864	AR001855-N ver	AR002547	AR1380090 ea	AR001829	AR0042213
<b>RK-20MM</b>	AR001887	AR002864	AR001855-N ver	AR002546	AR1380150 ea	AR001815	AR002820
<b>RKA-18MM</b>	AR001857	AR002864	AR001855-N	AR002546	AR1380090 ea	AR001829	AR0042213
<b>RKA-20MM</b>	AR001887	AR002864	AR001855-N ver	AR002547	AR1380090 ea	AR001515	AR002820
<b>RKV</b>	AR001857	AR001828	AR001856	AR002546	AR1380150 ea	AR001829	AR0042213
<b>XW-20MM</b>	AR002782	AR002780	AR002781	AR002542	AR2784 ea	-	AR002778
<b>XW-22MM</b>	AR002783	AR002780	AR002781	AR002543	AR002785	-	AR002779
<b>XWA-20MM</b>	AR002782	AR002780	AR002781	AR002542	AR002784	-	AR002778
<b>XWA-22MM</b>	AR002783	AR002780	AR002781	AR002543	AR002785	-	AR002779
<b>SXW-18MM</b>	AR002874	AR002871	AR002873	AR002548	AR002875	-	-

**AR PUMP KITS**

Original factory-direct repair kits. See previous page for kit selection chart. Don't see what you're looking for? Give us a call. We stock a broad selection of AR replacement parts. AR piston kits contain all that you need to repair broken pistons, O-rings, washers, nuts, plungers...YOU GET IT ALL!



PART NO.	MODEL NO.	KIT DESCRIPTION
8.720-573.0	AR001804	Packing
8.720-574.0	AR001805	Packing, 20 mm
8.740-118.0	AR001806	Pump
8.720-575.0	AR001815	Piston
8.720-578.0	AR001825	Valve Kit
8.720-579.0	AR001826	Piston Bolt
8.720-581.0	AR001828	Valve
8.720-582.0	AR001829	Ring, Support, XRA / XRV*
8.720-583.0	AR001830	Repair, AR 2882, O-Rings Only
8.720-585.0	AR001842	Piston, XRA / XRV*
8.720-586.0	AR001843	Piston, XRA, XR
8.720-592.0	AR001855	Oil Seal, XRA*
8.720-593.0	AR001856	Oil Seal, XRV
8.720-594.0	AR001857	Packing, XRA / XRV*
8.720-596.0	AR001860	Seal, Oil, XTV*
8.720-597.0	AR001864	Valve Kit
8.720-598.0	AR001865	Oil Seal
8.720-599.0	AR001866	Water Seals
8.720-601.0	AR001869	Repair Unloader
8.720-602.0	AR001872	Oil Seal
8.720-603.0	AR001873	Oil Seal Kit Complete
8.720-604.0	AR001874	Packing
8.720-606.0	AR001887	Water Seals
8.720-611.0	AR002031	Viton Seal, XRA
8.720-612.0	AR002043	Oil Seal
8.720-613.0	AR002044	Seal
8.720-632.0	AR002544	Piston, XM*
8.720-633.0	AR002546	Piston XRCA / XRCV
8.720-643.0	AR002624	Seal
8.720-644.0	AR002628	AR Piston #2628
8.720-649.0	AR002697	Repair, Combination Set
8.720-651.0	AR002740	Support Ring, XM*
8.720-652.0	AR002741	Water Seal, XM*
8.720-655.0	AR002747	Packing, XMA* 18 mm
8.720-658.0	AR002776	Hot / Dry Cup
8.720-661.0	 AR002780	Valve, XWA8G30N-SX
8.720-662.0	AR002781	Seal, XWA8G30N-SX
8.720-663.0	AR002782	Piston Seal, XWA8G30N-SX
8.720-665.0	AR002784	Piston Guide, XWA8G30N-SX
8.720-667.0	AR002786	Oil Seals, XMA35G25N
8.720-668.0	AR002787	Oil Seals
8.720-684.0	AR002864	Valve Kit, RK*
8.702-623.0	AR002278	Hot Pack Kit

\*Series

**CAT TRIPLEX PUMPS**



■ Direct Drive



8.702-444.0



8.702-381.0



8.702-464.0



9.113-051.0



9.113-054.0



9.113-046.0



9.109-786.0



8.702-436.0

PART NO.	MODEL NO.	GPM	PSI	RPM	SHAFT DIA	SHIP WT
<b>SOLID SHAFT MODELS</b>						
8.702-444.0	56	5.5	3500	1210	24 mm	29 lbs.
8.702-440.0	530	5.0	2500	1100	24 mm	26 lbs.
8.702-449.0	660	10.0	3000	1429	30 mm	44 lbs.
9.113-045.0	700	4.7	5000	1750	24 mm	29 lbs.
8.702-429.0	310	4.0	2200	950	20 mm	20 lbs.
8.702-381.0	310S	4.0	2200	950	20 mm	20 lbs.
8.702-464.0	5CP3120	4.5	3500	1750	20 mm	20 lbs.
9.113-051.0	5CP3120CSS	4.5	3500	1645	20 mm	20 lbs.
8.702-465.0	5CP5120	5.0	3000	1415	20 mm	20 lbs.
9.113-052.0	5CP5140CSS	5.5	3500	1500	20 mm	20 lbs.
<b>DIRECT DRIVE ELECTRIC FLANGED MODELS</b>						
9.113-048.0	4DX20ER	2.0	2000	3450	5/8"	11 lbs.
9.113-049.0	4DX27ER	2.7	2000	3450	5/8"	11 lbs.
9.113-053.0	5SP30ELU	3.0	3000	1750	1-1/8"	13.2 lbs.
9.113-054.0	5SP35ELU	3.5	2500	1750	1-1/8"	13.2 lbs.
9.113-055.0	5SP40ELU	4.0	2000	1750	1-1/8"	13.2 lbs.
<b>DIRECT DRIVE GAS FLANGED MODELS</b>						
9.113-046.0	4DNX25GSI	2.5	3000	3450	3/4"	11 lbs.
9.113-047.0	4DNX27GSI	2.7	3000	3450	3/4"	11 lbs.
9.113-050.0	4DX29GUIF	2.9	2600	3450	3/4"	14 lbs.
9.109-786.0	4SPX32G1I	3.2	3000	3450	1"	18 lbs.
9.113-057.0	67DX39G1I	3.9	4000	3450	1"	18 lbs.
8.702-436.0	66DX35G1I	3.5	4000	3400	1"	27 lbs.
8.702-435.0	66DX40G1I	4.0	4000	3400	1"	27 lbs.
9.113-056.0	66DX40GG1	4.0	4000	3400	1"	27 lbs.



**COMET PUMPS AND PUMP KITS**

For use in homeowner or light commercial-duty pressure washers.



- One-Piece Bronze Connection Rods
- Built-in Unloader
- Increased surface area for lower operating temperatures Ultra High-Pressure Head



PART NO.	MODEL NO.	GPM	PSI	RPM	SHAFT DIA	INLET/OUTLET
9.802-357.0	AXD 2020 E	1.9	2000	3400	5/8" Hollow	3/4" FGH/3/8" MPT
8.702-576.0	AXD 3020 G	2.75	2000	3400	3/4" Hollow	3/4" FGH/3/8" MPT
8.715-286.0	AXD 2427 G	2.5	2700	3400	3/4" Hollow	3/4" FGH/3/8" MPT
8.750-238.0	BXD 2020 E	1.9	2000	3400	5/8" Hollow	1/2" FPT/3/8" MPT

Comet kits and parts are available for any Comet model. Call with model number for quick and accurate service.

PART NO.	MODEL NO.
8.721-902.0	Piston, 15 mm, FWD
8.721-903.0	Piston, 18 mm, FWD
8.718-556.0	Seal Kit, LWD, HP
8.721-979.0	Packing Kit, FWS / FWD
8.721-985.0	Seal Kit Oil, LW Series, Hollow
8.721-986.0	Seal Kit, ZWD4030G
8.721-987.0	Seal Kit, Hollow Shaft Pumps
8.721-989.0	Sealt Kit, AXD2020
8.721-988.0	Seal Kit, AXD3020
8.750-711.0	Seal Kit, BXD2020 E
8.721-996.0	Valve Kit ZWD / FWS / FWD / HW / FW / LW
8.721-997.0	Valve Kit, AXD 3020
8.725-562.0	Valve Kit, BXD 2020

**COMET PUMPS & PUMP KITS- MC25-GR (WITH GEAR REDUCER)**

Perfect for Soft Wash, Ag Spraying, Lawn Care, Nursery, Pest Control, Mold Removal & Insulation applications.



- Twin Diaphragm, Low Pressure
- DURAphragm Technology
- Features Anodized Aluminum body for corrosion resistance
- Buna Diaphragm/Seals
- 3/4" Hydraulic Drive
- Includes Adjustable Pressure Regulator, manual dump lever & rails

PART NO.	GPM	PSI	RPM	SHAFT DIA	INLET/OUTLET	BYPASS
9.113-711.0	6.1	362	650	3/4"	3/4" / 3/8"	1/2"



## PISTON PUMPS - HYPRO



8.702-156.0

- Temperature Max: 140°F (except 5321)
- Temperature Max: 180°F (for 5321)
- Cast Iron Body
- Stainless-Steel Check Valves
- Complete with Base or Torque Arm
- Buna Cups
- 1/2 NPT Ports

PART NO.	HYPRO	GPM	PSI	RPM
<b>SOLID SHAFT</b>				
8.702-158.0	5320	2.0	500	1750
8.702-161.0	5321	2.2	1000	1750
8.702-167.0	5330	3.0	500	1750
<b>HOLLOW SHAFT</b>				
8.702-156.0	5315	1.5	500	1750
8.702-159.0	5320	2.0	500	1750
8.702-160.0	5321	2.2	1000	1750
8.702-166.0	5330	3.0	500	1750
8.702-146.0	Injector Head 5320 / 5330 Pump			
8.702-152.0	Injector Head 5321 / 5324 Pump			

## PUMP PARTS AND TOOLS



For 5300 Series pumps.

- A necessity for working on 5300 Series pumps
- Rugged Construction



Valve Seat Tools



Piston Repair Kit



Valve Cage Tools

PART NO.	DESCRIPTION
8.722-629.0	Piston Repair Kit, Model 5320 Pump
8.722-634.0	Piston Repair Kit, Model 5321 Pump
8.722-641.0	Check Valve Kit, All 5300 Pumps
8.712-510.0	Valve Cage Tool
8.712-512.0	Valve Seat Tool

Note: Piston Repair Kits have Buna Seal

## PUMP PACKING & SEAL KITS - GENERIC - A+



UPC, General Pump and Interpump replacement kits. Time-tested, quality parts meet or exceed factory specifications.



PART NO.	DESCRIPTION
8.900-438.0	Kit 1, Check Valve
8.900-440.0	Kit 2, Oil Seal
8.900-441.0	Kit 3, Cranshaft Oil Seal
8.900-442.0	Kit 8, New Style Packing Kit
8.900-443.0*	Kit 8, V-Packing
8.900-444.0*	Kit 9, Intermed Packing
8.900-447.0*	Kit 12, V-Packing
8.900-456.0*	Kit 19, V-Packing
8.900-463.0	Kit 23, Crankcase Oil Seal
8.900-464.0	Kit 24, Crankcase Oil Seal
8.900-466.0*	Kit 27, Plunger Repair
8.900-468.0*	Kit 28, Plunger Repair
8.900-471.0*	Kit 29, Plunger Repair
8.900-476.0	Kit 37, Oil Seal
8.900-485.0	Kit 83, Oil Seal
8.900-492.0	Kit 97, Packing

\*These are old style kits to replace components in Interpump / General pumps with two brown Buna-V packings (pumps built before the change was made to restop ring and black low-pressure seals).

## JETTER PULSE VALVES



- Replaces valve cap to create pulsation action, to move nozzle in pipe cleaning applications.

PART NO.	DESCRIPTION
8.755-228.0	For Legacy GB / GF / GP Series
8.755-229.0	For Legacy GM Series / GS Series
8.755-230.0	For Legacy GT Series
8.755-231.0	For Legacy GX Series, 4350 PSI
8.712-249.0	For GP 47 Series Pump
8.712-250.0	For GP TT Pumps

**ACCUMULATOR BY INTERPUMP**

Pulse dampener.



- PSI Max: 1350
- GPM Max: 10
- 3/4" MPT Connector
- Weight: 1 lbs.

PART NO.	MAX PSI	MAX GPM	DESCRIPTION
8.711-148.0	1350	10	Accumulator

**ACCUMULATOR - PULSE DAMPENER**

Pulse dampener.



- Precharge Pressure PSI: 580
- Temperature Max: 180°F

PART NO.	WORKING PSI	CAPACITY	INLET
8.711-145.0	3100	21.4 CU"	1/2" F
8.711-146.0	3100	6.1 CU"	3/8" F
8.711-147.0	4400	2.5 CU"	3/8" F

**INTERPUMP / GENERAL PUMP - V-PACKING INSERTION TOOL KIT**



- Contains inserting tools for installing 20 mm, 22 mm and 24 mm V-packings in the packing gland
- Prevents damage to sealing surfaces

PART NO.	DESCRIPTION
8.712-519.0	V-Packing Kit
9.109-643.0	V-Packing Kit, 15mm and 18mm, 63 Series

**PUMP TOOLS - EXTRACTOR PLIERS & DENTAL PICK**



- Indispensable for Pump Repair
- Excellent for removing O-rings, seals, and more
- 6" Long Dental Pick
- Stainless-Steel
- Knurled Handle
- Double-End

PART NO.	DESCRIPTION
8.707-467.0	Dental Pick
9.802-568.0	Pliers, Seal Extractor

**PUMP PACKING EXTRACTOR HAMMER & SOCKETS**

Virtually unbreakable sockets will pull packings from Interpump, General and other brand pumps.

Easy to use: Slide-Hammer (shown below) attaches to slotted socket - which expands inside the packing gland. The slide hammer then pops the packing gland brass out of the head to facilitate easy seal repairs without damage to brass support rings.



PART NO.	DESCRIPTION
----------	-------------

**SLIDE HAMMER**

8.712-513.0	Hammer Only
-------------	-------------

**SOCKETS FOR REGULAR SLIDE HAMMER**

8.712-516.0	18 mm Socket
8.712-515.0	15 mm Socket
8.712-517.0	20 mm Socket
8.712-518.0	22 mm Socket
8.712-520.0	25 mm Socket

**LARGE SLIDE HAMMER**

8.712-521.0	Large Slide Hammer
-------------	--------------------

**SOCKETS FOR LARGE SLIDE HAMMER**

8.712-523.0	30 mm Socket
8.712-524.0	38 mm Socket
8.712-525.0	45 mm Socket

**INTERPUMP PACKING / EXTRACTION TOOL**



Expansion tool inserts into packing gland to remote lodged packing components



PART NO.	DESCRIPTION
----------	-------------

8.712-522.0	Extractor Only
-------------	----------------

**EXPANSION SOCKETS FOR EXTRACTOR ABOVE**



8.712-526.0	15 mm, Ref Kit 86 and 97
8.712-528.0	20 mm, Ref Kit 8 and 19
8.712-529.0	22 mm, Ref Kit 12
8.712-530.0	24 mm, Ref Kit 16

Note: 15 mm Expansion Sockets also Fit Admiral Pump W-Series Pumps.

**PUMP OIL**



- Quality mineral base lubricating oil ideal for use in high pressure piston precision plunger pumps.
- Blended with wear, rust and foam inhibitors.
- Available in 10W30 & 10W40

PART NO.	DESCRIPTION
8.923-425.0	 Pump Oil 10W40, Quart
8.901-077.0	 Pump Oil 10W30, Quart
8.901-080.0	 Pump Oil 10W30, Case (12 Quarts)

**PUMP LUBE**



- A premium-quality lubricating oil fortified with additives to reduce friction, foaming and corrosion.
- Ideal for use in heavy industrial applications requiring hydraulic based lubricant.

PART NO.	DESCRIPTION
8.756-854.0	Pump Lube, Quart
9.808-016.0	Case Lot, Qty 12

**PUMP LUBE**



- A multi-viscosity SAE 80W 90 lubricant with anti-friction, anti-foaming and corrosion-inhibitor additives.
- Use in Admiral Geared Speed Reducers and Interpump / General RS99, RS151, PTO and other high-speed gear boxes.

PART NO.	DESCRIPTION
8.756-728.0	Gear Lube, 2-1/2 Gallons

**GP PUMP PACKING / EXTRACTION KIT - COMPLETE**



- 13 mm - 24 mm in a Carrying Case
- Slide Hammer
- 13 mm, 15 mm, 18 mm, 20 mm, 22 mm and 24 mm Sockets
- Fits General Pumps

PART NO.	DESCRIPTION
8.723-619.0	Puller & Packaging Kit

**GEAR REDUCTION**



Fits Legacy, Admiral, Bertolini, GP, Interpump, Comet, Udor & Hawk.



- Engine-to-Pump Drive Units
- 2.18 to 1 Reduction Ratio (3,675 Eng. RPM = 1,750 Pump RPM)
- Engine Shaft Size = .0984", 1", 1-1/8" & 3/4"

PART NO.	DESCRIPTION
8.710-332.0	24 mm Pump x 1-1/8" Engine
8.710-333.0	30 mm Pump x 1" Engine
8.715-344.0	25 mm Pump x 1" Engine, B18
8.715-342.0	24 mm Pump x 1" Engine, B18
8.749-925.0	24 mm Pump x 0.984" / 25 mm Engine, B18
8.749-922.0	24 mm Pump x 3/4" Engine, B5
8.754-767.0	25 mm Pump x 1-1/8" Engine, B24
8.710-334.0	30 mm Pump x 1-1/8" Engine
8.710-336.0	24 mm Pump x 1-1/8" Engine

**ANTI-SEIZE COMPOUND**

Recommended for all metal-to-metal, power-drive assemblies. Facilitates removal after use.



- Copper-Graphite or Nickel
- Copper-graphite high-torque for high temperature to 1800°F
- Nickel continues to work up to 2400°F
- Stops rust, galling and seizure on pulley / shaft or gear / shaft interfaces

PART NO.	DESCRIPTION
8.704-638.0	Blister Pack, 1 application, Copper - Graphite
8.704-641.0	8 oz. Brush Top Can - Nickel

**GEARED REDUCTION UNITS - INTERPUMP / GENERAL PUMP**



For use with 1450 RPM Interpump, General Pumps & Admiral A-W99.

- Eliminates Belts, Pulleys and Belt Guards
- Engine-to-Pump Drive Units
- Improve Efficiency



**RS99:**  
2.4:1 Gear Reduction (3480 Engine RPM = 1450 RPM Pump) for 3-5 HP Briggs, Honda-Tecumseh-Kohler with 3/4" Shaft.



**RS151:**  
2.2:1 Gear Reduction (3190 Engine RPM = 1450 RPM Pump) for 7-18 HP Briggs, Honda Engines with 1" or 1-1/8" Shaft (must specify). Use with the appropriate size: "WS" Series Interpump, "TS" Series General Pump.

PART NO.	ENGINE SHAFT
RS-99	
8.710-321.0	3/4"
RS-151	
8.710-322.0	1"
8.710-324.0	1-1/8"

**PTO GEARED MULTIPLIER**



- 1 to 1.9 Speed Multiplier
- 1-3/8" Splined Shaft (Same shaft as standard tractor PTO)
- 540 RPM PTO speed multiplied to 1,026 RPM at pump shaft
- For Pumps with a 24 mm Shaft

PART NO.	DESCRIPTION
8.710-319.0	Gear Multiplier

**PUMPTECH PUMP**

The Pumpteck Pump is a twin plunger design originally used on the Hotsy model Sport 500.



- PSI Max: 1000
- GPM Max: 2.0

PART NO.	DESCRIPTION
8.715-240.0	Pump-Sport 500
8.707-369.0	Cranshaft
8.707-370.0	Seal Kit with Plunger
8.700-187.0	Check Valve Kit

**FLANGES - LEGACY**



- Direct attachment of Legacy Pumps to NEMA Standard C-Face Motors.

PART NO.	NEMA FRAME	PUMP SERIES
8.754-098.0	184 TC / 215 TC	GM
8.754-099.0	184 TC / 215 TC	GT-GX

**FLEX COUPLERS - LEGACY**



- Pump shaft couplers.
- Direct-drive self-adjusting resilient coupling Legacy pumps to NEMA Standard Motor Shafts.

PART NO.	MOTOR DRIVE COUPLING	PUMP SERIES
8.754-100.0	1-1/8" x 24 mm	GM
8.754-101.0	1-3/8" x 24 mm	GM
8.754-103.0	1-3/8" x 25 mm	GT-GX

**FLANGES - INTERPUMP / GENERAL PUMP**



- Direct attachment of Interpump / General Pumps to NEMA Standard C-Face Motors.

PART NO.	NEMA FRAME	PUMP FRAME SIZE
8.709-613.0	56 / 145TC	56 / 145TC
8.709-615.0	184TC*	184TC*
8.709-616.0	215TC**	215TC**
8.709-870.0	8-13 HP (G)	8-13 HP (G)

\*W995 / GD \*\*W913 / GM

**FLEX COUPLERS - INTERPUMP / GENERAL PUMP**



- 24 mm pump shaft couplers. Direct-drive flex coupling 24 mm Interpump / General and Admiral XLS Series pumps to NEMA Standard Motor Shafts.

PART NO.	NEMA FRAME	DRIVE SHAFT
<b>2-PIECE COUPLER</b>		
8.709-617.0	56 A	5/8"
8.709-619.0	145T	7/8"
8.709-621.0	184 T	1-1/8"
8.709-624.0	215 T	1-3/8"
8.709-869.0	Gas (Aluminum)	1"
8.701-262.0	Rubber Bumper - Replacement	



## PUMP TECHNICAL INFORMATION

Correct pump installation is essential for optimum performance. It is recommended that the pump flow capacity be oversized for the actual flow required. For optimum running of the system, the water circulated through the regulating valve should not exceed 10-15% of the pump flow. Recirculating too much water can generate heat in the supply tank increasing the cavitation risk.

### FREQUENTLY ASKED QUESTIONS

**How much should you reduce the pump RPM to achieve a lower flow capacity?**

$$\text{Required RPM} = \text{Expected Capacity} \times \frac{\text{Max RPM Allowed}}{\text{Max Allowed Capacity}}$$

**What diameter of pulley must I use to achieve the correct pump RPM?**

$$\frac{\text{External Diameter of the Engine}}{\text{Motor Pulley}} = \text{External Diameter of the Pump Pulley} \times \frac{\text{Pump RPM}}{\text{Engine / Motor RPM}}$$

**What if I cannot change the engine / motor pulley?**

$$\text{External Diameter of the Pump Pulley} = \frac{\text{External Diameter of the Engine}}{\text{Motor Pulley}} \times \frac{\text{Engine / Motor RPM}}{\text{Pump RPM}}$$

**If the engine / motor is running at a lower RPM than the maximum pump RPM allowed, what will be the pump flow capacity?**

$$\text{Attainable Maximum Capacity} = \text{Engine / Motor RPM} \times \frac{\text{Max Capacity Indicated on Label}}{\text{Max RPM Indicated on Label}}$$

**What is the approximate power required to achieve the maximum performances allowed?**

$$\text{Required Electric Motor HP} = \frac{\text{PSI} \times \text{GPM}}{1460} = \text{Electric Motor HP}$$

$$\text{Required Gas Engine HP} = \frac{\text{PSI} \times \text{GPM}}{1460} \times 1.30 = \text{Gas Motor HP}$$

### CONDITIONS TO PREVENT PUMP CAVITATION

Minimum difference in height HZ (Pos / Neg) between pump and water level.

The minimum inlet pressure value of the pump is limited by the cavitation phenomenon. Cavitation is the forming of vapor bubbles when the local pressure is below the vapor pressure of the liquid. Bubbles flow together with the liquid and when they reach a higher pressure area, they collide, generating abnormal stresses that are extremely dangerous to the pump components. To avoid the risk of cavitation, it is necessary that the pump installation is correct.



**YAMADA PUMPS**



Air-powered double diaphragm pump, "Reliable Performance Since 1905". The answer to difficult product transfer problems. Air-drive allows freedom from electrical hazards or explosion-proof motor requirements. Choose from various wetted-parts materials to customize the pump to the chemical being pumped. Yamada's smaller pumps are often used for pumping car wash chemical for 'low-pressure' functions. The 1/2" pump is also ideal for rapidly pumping oil, soap, etc., from 55 gallon barrels. Larger pumps are used for high-volume product transfer. Since all pumps are designed without rotating parts, they can also handle abrasive liquids such as ceramic slip, sand slurry or enamel frit without damage. Have a unique challenge? Call us for help!



8.702-180.0

8.702-183.0

- PSI: 100
- Temperature: 180°F
- Environmentally-Friendly Non-Lube Air Valve
- Automatic Start/Stop
- Non-Stalling Air Valve - Positive Switching Every Stroke and Won't Ice Up
- Outside Accessible Air Valve: Easy Inspection & Maintenance
- Bolted Flange Connections: Leak-free & Easy Maintenance
- Built-in Abrasion and Chemical-Resistance
- Virgin Diaphragm Material Lasts Twice as Long as Other Pumps
- With 20-100 PSI Drive Air:
  - 1/4" Model Delivers 3.4 GPM
  - 1/2" Model Delivers 15 GPM
  - 3/4" Model Delivers 19.5-27.3 GPM
  - 1" Model Delivers 35.7-48.3 GPM
- Infinitely Variable Flow Control Regulated by Opening or Closing Discharge Side Valve and/or Fluctuating Air Supply

PART NO.	INTAKE AND DISCHARGE	AIR INLET W/BALL VALVE	AIR EXHAUST W/B-I MUFFLED	PUMP BODY	DIAPHRAGM MATERIAL	MAX FLOW @ 100 PSI	MAX SOLID
8.702-180.0	1/4" FPT	1/4" FPT	3/8" FPT	Poly	Teflon®	3.4 GPM	N/A
8.702-201.0	3/8" FPT	1/4" FPT	3/8" FPT	Poly	Santoprene®	6 GPM	1/32"
8.702-182.0	1/2" FPT	1/4" FPT	3/8" FPT	Poly	Hytrel®	15 GPM	1/32"
8.702-183.0	1/2" FPT	1/4" FPT	3/8" FPT	Poly	Santoprene®	15 GPM	1/32"
8.702-184.0	1/2" FPT	1/4" FPT	3/8" FPT	Poly	Teflon®	15 GPM	1/32"
8.702-190.0	3/4" FPT	1/4" FPT	3/4" FPT	Poly	Teflon®	27.3 GPM	1/16"
8.702-192.0	1" FPT	3/8" FPT*	3/4" FPT	Poly	Neoprene	48.3 GPM	3/16"
8.702-193.0	1" FPT	3/8" FPT*	3/4" FPT	Poly	Hytrel®	48.3 GPM	3/16"
8.702-194.0	1" FPT	3/8" FPT*	3/4" FPT	Poly	Teflon®	48.3 GPM	3/16"
8.702-202.0	1-1/2" FPT	1/2" FPT*	3/4" FPT	Alum	Buna-N	116 GPM	9/32"

\*With air-cock instead of ball valve

**YAMADA PUMPS DIAPHRAGM KITS**



To minimize downtime, Yamada pumps are designed for quick, trouble-free maintenance. Pump diaphragms, balls and seats can be replaced in 20 minutes or less and with little chance of leaks commonly associated with other diaphragm pumps.

- Kits include everything required for routine maintenance



PART NO.	KIT	PUMP SIZE	YAMADA PUMP NO.
8.703-277.0	Teflon®	1/4"	100381
8.703-278.0	Hytrel®	1/2"	100383
8.703-279.0	Santoprene	1/2"	100384
8.703-281.0	Teflon®	1/2"	100385
8.703-282.0	Neoprene	3/4"	100391
8.703-283.0	Buna	3/4"	100392
8.932-947.0	Teflon®	3/4"	100394
8.703-284.0	Neoprene	1"	100396
8.703-285.0	Hytrel®	1"	100397
8.703-286.0	Teflon®	1"	100398
8.703-320.0	Buna	1-1/2"	100415

Note: Individual Components (O-rings or Diaphragms Only, For Example) Also Available. Call For Pricing and Delivery.



## UNLOADER VALVES - UU1 UNIVERSAL

The Legacy Universal Unloader is unique in that it allows for height or width adjustments making it ideal for any pump.



- PSI: 3500
- GPM: 6.0
- Temperature: 195°F
- Forged-Brass Body
- 1/2" NPT Inlet
- 3/8" NPT Outlet
- Stainless-Steel and low friction, wear-resistant plunger
- Weight: 16.1 oz.
- Patent US 8,313,311 B2'

PART NO.	DESCRIPTION
----------	-------------

9.175-018.0	Legacy Universal Unloader (UU1)
-------------	---------------------------------

Note: Legacy Universal Unloader (UU1) will not fit Legacy Pump GF 3530F

**Adjusting inlet port**

1.- Push up inlet port to make it shorter.

2.- Pull down inlet port to make it longer.

**Adjusting horizontal sliding connector**

1.- Turn the connector clockwise direction to make it shorter.

2.- Turn the connector counterclockwise direction to make it longer.

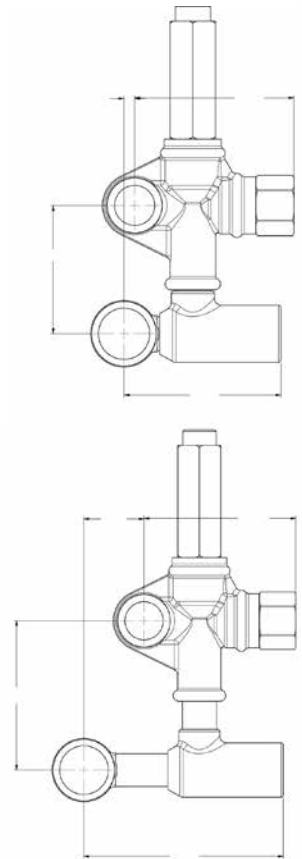

## UNLOADER VALVES - VBT SERIES

A trapped pressure direct mount unloader valve.



- GPM: 6.6
- Temperature: 195°F
- Weight: 1.95 oz.
- Brass, Stainless, Buna-N

PART NO.	DESCRIPTION	CONNECTION	PSI	FITS PUMP
8.754-703.0	Universal, VBT Direct Mount	3/8" FPT Inlet x 3/8" MPT Outlet	1500	FOG
8.754-696.0	Universal, VBT Direct Mount	1/2" FPT Inlet x 3/8" MPT Outlet	3000	LB, LP, LF
8.754-700.0	Universal, VBT Direct Mount	1/2" FPT Inlet x 3/8" MPT Outlet	4000	LB, LP, LF
8.754-701.0	Universal, VBT Direct Mount	1/2" FPT Inlet x 3/8" MPT Outlet	4000	LB, LP, LF
8.754-702.0	Universal, VBT Direct Mount	1/2" FPT Inlet x 3/8" MPT Outlet	4000	LM, LS

**UNLOADER VALVES - APR SERIES**

Integral Automatic Pressure Regulator for Admiral Pumps: WE - WG - WEL - XLS - XLE - XLG bolt on for Admiral and Legacy pumps. Trapped-pressure regulator specifically designed for use on the Admiral plunger pumps. Integral inlet, bypass and outlet eliminate the need for bypass hose.



- PSI: 3200
- GPM: 6.0
- Temperature: 195°F
- Forged-Brass Body
- 3/8" MPT Outlet
- Stainless-Steel Plunger and Seat Valve
- Weight: 29 oz.

8.703-401.0

PART NO.	DESCRIPTION	INLET
8.703-401.0	APR-Brass / Black	3/8"
9.802-365.0	APR-Brass / Black	1/2"
8.900-760.0	Seal Repair Kit	3/8"
8.900-761.0	Seal Repair Kit	1/2"

**UNLOADER VALVES - VR53**



- PSI: 3630
- GPM: 8.0
- Temperature: 194°F
- 3/8" FPT Inlet and Outlet, 1/4" FPT Bypass
- Adjustable Pressure Setting Nut
- Heavy-Duty Forged-Brass Body
- Stainless-Steel Ball and Valve Seat
- High-Temperature Viton Seals
- Adjustable Upper-Pressure Limit Lock

PART NO.	DESCRIPTION	PSI	GPM
8.753-027.0	VR53 without Knob	3630	8
8.753-026.0	VR53 with Knob	3630	8

**UNLOADER VALVES - VR54/56**

Basic valves, premium performance.



- Temperature: 194°F
- Forged-Brass Body
- Stainless-Steel Seat and Piston
- 3/8" MPT Inlet, Outlet & 3/8 FPT Bypass

**VR54 Black Regulator / Unloader**

- PSI: 2030
- Max PSI: 2175 PSI
- GPM: 8.0
- Weight: 15 oz.

**VR54 Red Regulator / Unloader**

- PSI: 2610
- Max PSI: 2900 PSI
- GPM: 8.0
- Weight: 13.7 oz.

**VR56 Regulator / Unloader**

- PSI: 3625
- Max PSI: 3400 PSI
- GPM: 8.0
- Weight: 15 oz.

**Repair Kits**

- For Use with VR54/VR56 Regulator/Unloaders

PART NO.	DESCRIPTION
8.753-028.0	VR54 Black with Knob
8.753-029.0	VR54 Red with Knob
8.753-017.0	VR56 with Knob

**UNLOADER VALVES - VR56/ VBA35 SERIES**



Commonly used on Legacy HD Pumps.



- VBA35**
- PSI: 3500
- GPM: 6.6
- VB56**
- PSI: 3650
- GPM: 8.0

PART NO.	DESCRIPTION	PSI	GPM
<b>VBA35 FOR LEGACY HD MODELS</b>			
9.803-899.0	GG, GD, GE	3500	6.6
9.803-900.0	GM, GS	4000	6.6
<b>VB56 FOR LEGACY HD MODELS</b>			
8.753-011.0	GM, GS	3650	8.0



## UNLOADER VALVES - VRT3 SERIES



Basic valves, premium performance.



- GPM: 8.0
- Temperature: 200°F
- Forged-Brass Body
- Stainless Internals
- 3/8" Inlet, Outlet, Bypass
- EZ Start models do not have dual inlets

PART NO.	DESCRIPTION	PSI	GPM
8.750-297.0	Yellow Spring	2320	8.0
8.750-298.0	Blue Spring	3630	8.0
8.750-299.0	 Black Spring	4500	8.0
8.750-300.0	 Black with EZ Start	4500	8.0
8.750-955.0	Black with Switch	4500	8.0
8.750-956.0	 Black with Knob Switch	4500	8.0
<b>REPAIR KITS</b>			
8.750-709.0	Kit for Blue & Yellow Spring Unloaders	2320 / 3630	8.0
8.750-710.0	Kit for Black Spring Unloaders	4500	8.0
9.802-694.0	Old Style VRT 605, 606, 607	Up to 4500	8.0

## UNLOADER VALVES - VRT100 HIGH-VOLUME SERIES



- GPM: 26.4
- Temperature: 194°F
- 1/2" FPT, Inlet, Outlet & Bypass
- Stainless Internals
- Forged-Brass Body

PART NO.	DESCRIPTION	PSI	GPM
8.753-726.0	Blue with Knob	Up to 5075	26.4
8.753-443.0	Yellow without Knob	Up to 2760	26.4
8.753-444.0	Blue without Knob	Up to 5075	26.4
8.753-727.0	Blue with Microswitch 120 / 240 VAC - without Knob	Up to 5075	26.4
8.753-728.0	VRT100 Repair Kit	Up to 5075	26.4

## UNLOADER VALVES - PULSAR RV SERIES



- GPM: 8.0
- Temperature: 195°F
- Pulsar RV Blue Rated 4050 PSI, Max PSI: 4500
- Pulsar RV White Rated 2300 PSI, Max PSI: 2600
- All Stainless-Steel Valves
- Pressure Actuated
- Forged Body
- 3/8" FPT Inlet, Outlet
- Two 3/8" FPT Bypass Ports

PART NO.	DESCRIPTION	GPM
8.754-867.0	Pulsar RV, White, with Knob	8.0
8.754-870.0	Repair Kit- Pulsar RV	8.0
8.754-866.0	Pulsar RV, Blue, without Knob	8.0
8.754-869.0	Pulsar RV, Blue, with Knob & Switch	8.0

## UNLOADER VALVES - VB7 SERIES



Fits GP/Interpump 63 Series, CAT 45F pumps as well as many other pumps requiring up to 8 GPM - 3650 PSI max pressure.



- PSI Max: 3650
- Temperature: 195°F
- Weight: 19.7 oz.

PART NO.	DESCRIPTION	PSI
8.712-741.0	without Knob, 3/8 MPT Inlet, 3/8 FPT Outlet & Bypass	3650
8.904-580.0	w/ Knob, 2.1 Fixed Inj., 3/8 MPT Inlet & Outlet	3650
8.704-488.0	Repair Kit	
8.712-735.0	Knob Only	

## UNLOADER VALVES - VB8 SERIES



- Trapped Pressure
- 8 GPM
- 3200 MIN-3650 PSI Max
- Temp- 195 Deg

PART NO.	DESCRIPTION
9.802-362.0	w/ Knob & Switch, 5 Amp Microswitch, 3/8" MPT Inlet, 3/8" FPT Outlet & Bypass
8.757-462.0	w/o Knob, 3/8" MPT Inlet, 3/8" FPT Outlet

### UNLOADER VALVES - VB130/135 SERIES



Trapped Pressure Unloader for the 51 & 60 Series pumps. Fits CAT 2SF pumps as well as others.



- PSI Max: 2600
- Temperature: 195°F
- 3/8" MPT Inlet and Outlet
- 3/8" FPT Bypass
- Stainless-Steel Plunger
- Stainless-Steel Valve Seat
- Weight: 14.7 oz.

PART NO.	DESCRIPTION	TEMP
8.712-739.0	VB 130 Without Knob	195°F
8.904-579.0	VB-135- with Knob, Banjo Connection, Hollow Screw Fitting	195°F
9.802-006.0	Repair Kit	195°F
8.712-735.0	Knob Only	195°F

### UNLOADER VALVES - VB85 / 280 SERIES



Fits CAT 2SF pumps and other pumps. This pressure sensitive regulating unloader is designed for single or multiple pumps, weep or multi-nozzle systems.



- GPM: 21
- Temperature: 200°F
- Pressure Actuated
- Forged-Brass Body
- Stainless-Steel Plunger and Seat
- 1/2" FPT Inlet, Outlet, Bypass
- Weight: 45 oz.

PART NO.	DESCRIPTION	PSI	GPM	MAX PSI
8.751-964.0	VB85/ YUB21405, Blue Spring	4050	21	4500
8.751-963.0	VB85/ YUW21235, White Spring	2300	21	2600

### UNLOADER VALVES - VB80 / 400 STAINLESS-STEEL



- Rated PSI: 5800, Max PSI: 6500
- GPM: 21.0
- Forged Stainless-Steel Body
- All Stainless-steel Valve Parts
- Viton Seals
- 1/2" FPT Inlet, Outlet, Bypass

PART NO.	DESCRIPTION	GPM	TEMP
8.712-656.0	VB 80/400 - YU2158	21	195°F
9.802-007.0	Repair Kit	21	195°F

### UNLOADER VALVES - VB200 HIGH-VOLUME SERIES



Fits CAT 2SF pumps and other pumps.



- PSI: 2175
- GPM: 52.5
- Temperature: 194°F
- Steel and Brass Body
- Large Plastic Knob (Removable)
- Lock Nut on Pressure Adjustment
- 1" FPT Inlet, Outlet, Bypass
- Two 5/16" - 18 Bolt Mounting Ports
- Hexagonal shaped check valve to avoid jamming
- Weight: 73.5 oz.

PART NO.	DESCRIPTION	PSI	GPM
8.712-754.0	VB 200 without Knob	2200	52.5
8.712-755.0	VB 200 with Knob	2200	52.5
8.704-583.0	Repair Kit	2200	52.5

### UNLOADER VALVES - VB75 / VB135 SERIES



The VB75 is an integrated unloader for Interpump and General Pump with 7.8 GPM - 3600 PSI max pressure. The VB135 fits Interpump "WW" Series pumps and General "TT" Series pumps with 6.5 GPM - 2600 PSI max pressure.

#### VB75

- Rated PSI- 3200, Max PSI 3650
- Temperature: 195°F
- 1/2" FPT Inlet, 1/4" FPT Gauge Port
- 3/8" FPT Outlet and Bypass
- Weight: 19.7 oz.

#### VB135

- Rated PSI: 2300, Max PSI: 2600
- Temperature: 195°F
- 3/8" FPT Inlet, 3/8" MPT Outlet
- 6.5 GPM
- Stainless Internals
- Forged-Brass Body
- Weight: 22.9 oz.



VB75



VB135

PART NO.	DESCRIPTION
<b>VB75</b>	
8.712-742.0	VB75 Direct Mount Control Set for EZ, 47, 60, 63 & W151 Series
8.704-488.0	Seal Kit
8.712-735.0	Knob Only
8.705-934.0	1/2" Bolt with Hole
<b>VB135</b>	
8.712-659.0	VB135- Direct Mount Control Set for WW & TT Series Pumps
8.712-735.0	Knob Only
9.802-006.0	VB 135 Repair Kit
8.705-935.0	3/8" Bolt with Hole





## UNLOADER VALVES - VB9 / VB10 TRAPPED PRESSURE SERIES



- PSI: 3600
- Rated PSI: 3200
- GPM: 8.0
- Instant Pressure Response
- Hex-Shaped Non-stick Check Valve
- 3/8" FPT Inlet, Outlet, Bypass
- Brass Valve Body / Stainless Ball and Seat
- Knob Included
- VB9 - Panel Mountable
- Reduces trapped pressure to 25% of operating pressure when unloading; allows easier gun trigger pull

PART NO.	DESCRIPTION
8.712-736.0	VB9 with Knob - YVB9K
8.715-462.0	VB9 with Knob and Pressure Switch - YVB9KMS2
8.715-489.0	VB9 with Check Valve and Pressure Switch - YVB9KMSS
8.712-745.0	VB10 with Knob - YU3678
8.704-548.0	Repair Kit VB9
8.704-561.0	Repair Kit VB10
8.901-056.0	Seal Kit VB10

## UNLOADER VALVES - VB350 / VB7 SERIES



Bigger. Stronger. Faster - 5650 PSI.



- PSI Max: 5650
- Rated PSI: 5075
- GPM: 10.0
- Temperature Max: 195°F
- Forged-Bronze Body
- Stainless-Steel Plunger and Valve Seat
- 3/8" FPT Outlet
- 1/2" F Bypass
- 3/8" MPT Inlet, 1/4" Gauge Port
- Weight: 31 oz.

PART NO.	DESCRIPTION	TEMP
9.802-360.0	Unloader, Red Knob (YU5075K)	195°F
9.800-106.0	Repair Kit, Red Knob	195°F
8.704-499.0	Repair Kit, Old VB 350	195°F

## UNLOADER VALVES - CONTROL SET "W" SERIES



Integrated Regulator & Unloader designed exclusively to fit Interpump & General Pump pumps.



- Mounts directly on pump inlet and outlet; internal bypass loop
- Pressure Actuated: "Instant-On"
- 3/8" MPT Inlet & Outlet, 1/4" HB (8.712-638.0, 8.712-643.0)
- 1/2" FPT Inlet, 3/8" MPT Outlet, 1/4" HB (8.712-644.0, 8.712-642.0, 8.712-647.0)
- Integrated Injector - Optional
- Pressure and flow-engineered for specific pump models

PART NO.	MODEL	GPM	PSI	PUMP
<b>"W" SERIES UNLOADERS WITHOUT INJECTORS</b>				
8.712-638.0	W1	3.0	1600	W905
8.712-643.0	W2	4.5	3000	W997
8.712-644.0	W2-L	6.0	3000	W201
8.702-883.0	W2 / W2L Rebuild Kit			
8.702-888.0	W1 / W1L Rebuild Kit			
<b>"W" SERIES UNLOADERS WITH INJECTORS</b>				
8.712-642.0	W2-1	4.5	3000	W997
8.712-645.0	W2L-1	4.5	3000	W201
8.712-647.0	W2L-2	6.0	3000	WS202
8.702-884.0	Injector Maintenance Kit			

## UNLOADER VALVES - KITS FOR K / ZK SERIES



Repair Kits for all K3, K5, K7 and K9 models.

PART NO.	DESCRIPTION
8.702-847.0	K5/K58 Maintenance Kit
8.702-849.0	K5/K60 Rebuild Kit
8.705-045.0	K5 Back Nut 3/4" NPT
8.702-858.0	K7/K70 Repair Kit
8.702-911.0	K9/K121 Repair Kit



**UNLOADER VALVES - K / ZK SERIES**



Unloaders relieve line pressure in bypass mode.



**ZK3 / ZK5**

- Temp: 165°F
- 3/8" FPT Inlet
- ZK3: 1500 PSI  
ZK5: 3000 PSI

**ZK7**

- Temp: 165°F
- 3/8" FPT Inlet
- 3500 PSI
- GPM: 2.11 - 10.8

**ZK1**

- Temp: 165°F
- 3/8" FPT Inlet
- 3600 PSI
- GPM: 2.3 - 10.8

**ZK9**

- Temp: 165°F
- 1/2" FPT
- 5800 PSI
- GPM 2.5 TO 13.2

PART NO.	MODEL	GPM	OUTLET
----------	-------	-----	--------

**ZK1**

8.712-602.0	ZK138	2.30 - 10.80	3/8" M
8.712-601.0	ZK1	2.30 - 10.80	1/2" M

**ZK3**

8.712-603.0	ZK3.0	2.10 - 3.00	3/8" M
8.712-605.0	ZK3.1	3.00 - 3.22	3/8" M
8.712-607.0	ZK3.2	4.22 - 5.55	3/8" M
8.712-609.0	ZK3.3	5.00 - 6.50	3/8" M
8.712-604.0	ZK3.0	2.10 - 3.00	1/2" M
8.712-606.0	ZK3.1	3.00 - 4.22	1/2" M
8.712-608.0	ZK3.2	4.22 - 5.55	1/2" M
8.712-610.0	ZK3.3	5.00 - 6.50	1/2" M

**ZK5**

8.712-611.0	ZK5.1	3.00 - 4.22	3/8" M
8.712-613.0	ZK5.2	4.22 - 6.60	3/8" M
8.712-615.0	ZK5.3	6.60 - 10.83	3/8" M
8.712-612.0	ZK5.1	3.00 - 4.22	1/2" M
8.712-614.0	ZK5.2	4.22 - 6.60	1/2" M
8.712-616.0	ZK5.3	6.60 - 10.83	1/2" M
8.715-478.0	Bypass plate for ZK3 / ZK5		

Note: 1. Use 8.705-045.0 back nut on bypass nipple when mounting 1/2" bypass line on ZK3 and ZK5 series. 2. Use restricted .156-.225 ID orifice in bypass line for smoother operation / pressure balancing.

**ZK7**

8.712-617.0	ZK7.0	2.11 - 3.00	3/8" M
8.712-618.0	ZK7.1	3.00 - 4.22	3/8" M
8.712-619.0	ZK7.2	4.22 - 6.60	3/8" M
8.712-620.0	ZK7.3	6.60 - 10.8	3/8" M
8.701-386.0	ZK7 - #0 Bypass Orifice 2.2 mm		
8.701-389.0	ZK7 - #1 Bypass Orifice 2.5 mm		

**Z9**

8.712-621.0	ZK9	2.50 - 13.20	1/2" M
-------------	-----	--------------	--------

**UNLOADER VALVES - HM MODEL**



- Pressure Adjustable: 0-3000 PSI
- Flow Range: 1.4 to 10.8 GPM
- Temperature: 185°F
- 3/8" FPT Inlet, Bypass, 3/8" MPT Outlet
- Excess Flow Bypassed to Maintain Selected Pressure
- Operates on Single / Multiple Gun Systems
- Brass Body, Stainless-Steel Valve & Seat

PART NO.	DESCRIPTION	PSI	GPM
8.712-622.0	HM Regulator / Unloader	0-3000	1.3-10.8
8.702-860.0	Repair Kit #72	0-3000	1.3-10.8

**UNLOADER VALVES - HYPRO-STYLE**



- PSI: 400 to 1500
- GPM: 4.0
- Temperature: 180°F
- 3/8" MPT Inlet and Outlet
- Buna Seals
- Weight: 8 oz.

PART NO.	PRESSURE	BYPASS	GPM
8.712-689.0	200-500	1/4" FPT	5.0
8.712-690.0	400-1000	1/4" FPT	5.0
8.712-691.0	800-1500	1/4" FPT	5.0
8.712-692.0*	400-1000		5.0
8.712-693.0*	800-1500		5.0
8.722-643.0	Repair Kit for All		

\*Bypass port not threaded, closed coupled

**UNLOADER VALVES - YU HIGH VOLUME**



- GPM: 21.0
- Temperature: 200°F
- 1/2" FPT Inlet and Outlet
- Two 1/2" FPT Bypass Ports
- Forged-Brass Body
- Stainless-Steel Internals

**YU-21235 YELLOW SPRING**

- PSI: 2300
- Rated Pressure: 2600 Max

**YU-21405 GREEN SPRING**

- PSI: 4050
- Rated Pressure: 4500 Max

PART NO.	DESCRIPTION	PSI
8.753-326.0	YU-21235 Yellow Spring	2600
8.753-168.0	YU-21405 Green Spring	4500



**UNLOADER VALVES - ST-230**



- PSI: 500 - 3600 PSI
- GPM: 8.0
- Temperature: 200°F
- 1/4" FPT Inlet and Bypass
- Mounts Off-Line - No Line Restrictions
- Brass Body, Stainless-Steel Piston & Seat
- Weight: 14 oz.

PART NO.	DESCRIPTION	GPM	TEMP
8.712-628.0	ST-230	8	200°F
8.757-359.0	Repair Kit	8	200°F

NOTE: Tamper proof wire and seal are not included

**UNLOADER VALVES - ST-280**



- PSI: 500 - 4060
- GPM: 8.0
- Temperature: 175°F
- Brass Housing, Stainless-Steel Valve
- 3/8" FPT Inlet, Outlet and 1/4" FPT Bypass
- Weight: 22.5 oz.

PART NO.	DESCRIPTION	PSI	GPM
8.712-674.0	ST-280	3600	8
8.701-654.0	Piston Seal Kit "C"	3600	8
8.701-653.0	Check Valve Kit "A"	3600	8

**UNLOADER VALVES - ST-261 SERIES**



ST-261 STD



ST-261/S



ST-261/I



ST-261/SI



ST-261 Bypass Switch Only

**ST-261 STANDARD**

- PSI Regulation: 0-3600
- GPM: 1.0 - 8.0
- Temperature: 176°F
- 3/8" FPT Inlet & Outlet  
1/4" FPT Bypass
- Stainless-Steel Plunger and Seat
- Forged-Brass Body and Viton Seals
- Weight: 22.5 oz.

**ST-261 / S UNLOADER WITH BYPASS  
ST-261 / I - UNLOADER WITH CHEMICAL INJECTORS  
ST-261 / SI UNLOADER WITH SWITCH AND INJECTOR**

- Micro Switch Specs; 115 VAC, 5A / 230 VAC, 3A
- Temperature: 176°F
- 3/8" FPT Inlet & Outlet  
1/4" FPT Bypass & Aux Port
- Siphon Rate- 10-1
- Switches at full bypass flow
- Wired N/C (may be wired N/O)

**ST-261 BYPASS SWITCH (ONLY)**

- Field-Mountable
- 10 AMP, 115 / 230V
- Switches at full bypass flow
- Wired N/C (may be wired N/O)

PART NO.	DESCRIPTION	PSI	GPM
<b>ST-261 STANDARD</b>			
8.712-681.0	ST-261 STD	0-3600	8
8.701-627.0	Repair Kit "B"	0-3600	8
8.701-650.0	Outlet Check Kit "A"	0-3600	8
<b>ST-261 / S- UNLOADER WITH BYPASS MICRO SWITCH</b>			
8.712-685.0	ST-261 / S	500-3625	8
8.701-647.0	Switch Seal Kit		
<b>ST-261 / I- UNLOADER WITH CHEMICAL INJECTORS</b>			
8.712-682.0	ST-261 / I / 1.8 mm	500- 3650	1.50-2.25
8.712-683.0	ST-261 / I / 2.1 mm	500- 3650	2.25-3.35
8.712-684.0	ST-261 / I / 2.4 mm	500- 3650	3.35-5.00
8.900-159.0	Injector Repair Kit without Barb		
8.701-648.0	Injector Repair Kit with Barb		
<b>ST-261 / SI- UNLOADER WITH MICRO SWITCH &amp; INJECTORS</b>			
8.712-686.0	ST-261 / SI-1		1.50-2.25
8.904-576.0	ST-261 / SI-2		2.25-3.35
8.904-577.0	ST-261 / SI-3		3.35-5.00
<b>ST-261 BYPASS MICRO SWITCH &amp; KIT</b>			
8.712-629.0	Complete Micro Switch Assembly		
8.701-642.0	Micro Switch Only		
8.701-647.0	Seal Kit - Micro Switch		

**UNLOADER VALVES - AR BOLT-ON**



- PSI Rated Pressure: 2600
- Fits RC, XT & XM Series Pumps
- 1/2" F Inlet
- 3/8" M Outlet

PART NO.	DESCRIPTION	GPM	BYPASS
8.712-582.0	AR20608 (4/B)	3.0-5.5	Aluminum, No Injector
8.712-564.0	AR20821 (3/B)	2.0-5.0	Aluminum, No Injector
8.712-573.0	AR20890 (4/B)	2.0-3.0	Aluminum, 2.0 Adj Injector
8.712-576.0	AR21039 (4/B)	2.0-3.0	Brass 2.0 Adj Injector
8.712-575.0	AR21040 (4/B)	3.0-4.0	Brass 2.2 Adj Injector
8.720-676.0	Seal Kit (4/B)		

Note: AR has discontinued the Combiset unloaders. Use Mini-Mate unloaders as replacements. For 22 mm twist coupler outlet models, add Part No. 8.709-546.0 (3/8" x 22 mm) to injector outlet.

**UNLOADER VALVES - GYMATIC - 3/B & VR35 3/B SERIES**



- PSI Rated Pressure: 3650
- GPM: 3.0-5.5
- Fits RK, RR, SXM, XM Series Pumps
- 3/8" M Outlet

PART NO.	DESCRIPTION	INLET
8.712-565.0	AR20242 (3/B)	1/2" F without Injector
8.712-563.0	AR20242G (3/B)	3/4" GHT & Filter, without Injector
8.712-574.0	AR20081 (3/B)	1/2" M Fixed Injector, 1.8 mm
8.712-567.0	AR20082 (3/B)	1/2" M Fixed Injector, 2.0 mm
8.712-568.0	AR20399 (3/B)	1/2" M Adj Injector, 1.8 mm
8.712-569.0	AR20400 (3/B)	1/2" F Adj Injector, 2.0 mm
8.720-642.0	AR2611 (3/B)	Repair Kit

**AR21669 - VR35 3/B**

- PSI Max: 4000
- GPM: 5.0
- Brass Bypass
- 1/2" M Inlet
- 3/8" M Without Injector

**AR24760 - VR35 3/B**

- PSI Max: 4000
- GPM: 5.0
- Brass Bypass
- 1/2" F Inlet
- 3/8" M Outlet Without Injector

PART NO.	DESCRIPTION	INLET	OUTLET
8.712-583.0	AR21669	1/2" M	3/8" M
8.720-903.0	AR24760	1/2" F	3/8" M

**UNLOADER VALVES - 22900A PRESSURE ACTUATED SERIES**



- Minimum PSI: 375 (Max PSI Listed Below)
- GPM: 2.2 - 13.0
- Temperature: 160°F
- Bellville Spring Washers Minimize Spikes
- Forged-Brass Bodies, Stainless Ball and Seat
- Four 1/4" Side Ports Enhance Versatility
- 1/2" FPT Inlet, Outlet and Bypass Ports
- Weight: 57.3 oz.

PART NO.	MODEL NO.	MAX GPM	MAX PSI	SPRING
8.712-709.0	22910A	13	800	Silver
8.712-710.0	22911A	13	1400	Yellow
8.712-711.0	22912A	13	2400	Red
8.712-708.0	22913A	13	3000	Orange
8.722-137.0	Repair Kit- 012099			

**UNLOADER VALVES - APM PRESSURE ACTUATED SERIES**



8.712-705.0



8.712-706.0

- Temperature: 160°F
- Unloads pressure in entire system when in bypass
- Forged-Brass Bodies
- Stainless-Steel Seat
- 3/8" FPT Inlet
- 3/8" FPT Outlet
- 1/4" FPT Bypass & Gauge Port

PART NO.	MODEL NO.	GPM	PSI
8.712-705.0	22760APM	8	145-3045
8.712-706.0	22765APM	5	580-4000

### UNLOADER VALVES - FLOW-ACTUATED



Designed for any pump that fits within the flow and pressure range of the unloader.



- Temperature: 160°F
- Unloads pressure in entire system when in bypass
- Forged-Bronze Body, Stainless-Steel Seat
- 3/8" FPT Inlet, 3/8" MPT Outlet
- 1/2" FPT Bypass

PART NO.	MODEL NO.	GPM	PSI
8.712-698.0	22650	3.0-4.5	0-3000
8.712-701.0	22654A	3.5-4.8	3000-4000
8.712-702.0	22655	4.5-5.5	0-3000
8.712-703.0	22656	4.5-6.5	0-3000
8.722-204.0	Seal Kit- 22666		

### PRESSURE RELIEF VALVES - SR/S3



For use as a backup to an unloader or main relief in an open system without a trigger operated spray gun.



- S-R Safety Valve: PSI: 3000 GPM: 1.3 to 10.0 3/8" M Inlet, 1/4" F Outlet
- S-3 Safety Valve: PSI: 500 to 10,000 GPM: 2.6 to 26.4 1/2" M Inlet, Side Discharge
- Bypass and Outlet
- Stainless-Steel Plunger and Seat
- Machined-Brass Bodies
- Adjustable Pop-Off Protection

PART NO.	DESCRIPTION	TEMP
8.711-215.0	S-R Valve/ ZKSR	165°F
8.711-227.0	S-3 Valve/ ZKS3	284°F

### PRESSURE RELIEF VALVES - TIMAX



- PSI Max: 870
- GPM Max: 53
- 3/4" F Inlet, 1/2" F, 1" F Bypass
- 1" FPT Bypass
- Brass-Body, Stainless-Steel Piston and Seat

PART NO.	DESCRIPTION	GPM	PSI
8.712-624.0	Timax Regulator Valve	53	870
8.702-844.0	Repair Kit		

NOTES: Lever control manual dump for bypass to relieve line pressure

### UNLOADER VALVES - MG4000 SERIES



"The world's best unloader valve" with a choice of PSI: 1500, 3000 or 4500.



- PSI: Up to 4500 PSI
- GPM: 10.0
- Temperature: 200°F
- Forged-Brass Body
- 3/8" FPT Inlet, Outlet and Bypass
- Auxiliary 1/4" Outlet
- Can be panel mounted
- Pressure limit indicated with color coded ring

PART NO.	DESCRIPTION	GPM	PSI
<b>WITHOUT KNOB</b>			
8.712-715.0	Yellow	10	1500
8.712-724.0	Black	10	4500
<b>WITH KNOB</b>			
8.712-716.0	Yellow	10	1500
8.712-719.0	Red	10	3000
8.712-725.0	Black	10	4500
8.704-567.0	Repair Kit- 463104K		



- **MG4000 WITH MICROSWITCH**
- 15 Amp Microswitch
- Panel Mountable
- Use for time-delay shutdown or as burner control
- Can be used as Normally Open (NO) or Normally Closed (NC)

PART NO.	DESCRIPTION	GPM	PSI
8.712-720.0	Red	15	3000
8.712-714.0	Blue	15	4000
8.712-727.0	Black	15	4500

**PRESSURE RELIEF VALVES - VS 200 / 180, HIGH PSI**



Prompt and effective damping against pressure spikes



- Rated PSI: 2600, Max PSI: 2900
- GPM: 52.5
- Temperature: 194°F
- 3/4" FPT Inlet x 1/2" FPT Bypass
- Weight: 29.4 oz.

PART NO.	MODEL NO.	GPM
8.712-753.0	VS 200/180	52.5
8.704-582.0	Repair Kit	

**PRESSURE RELIEF VALVES - VS 350, HIGH PSI**



Prompt and effective damping against pressure spikes. Perfect For Multiple Gun Applications as well.



- PSI: 5600
- Rated PSI: 5100
- GPM: 6.5
- Temperature: 195°F
- 3/8" FPT Inlet, Outlet and Bypass
- Weight: 16.8 oz.

PART NO.	MODEL NO.	GPM	PSI
8.712-756.0	VS 350	6.5	5600
8.704-611.0	Repair Kit		

**PRESSURE RELIEF VALVES - VS 220**



- PSI Max: 3600
- Rated PSI: 3200
- GPM: 6.3
- Temperature: 200°F
- Two 3/8" FPT inlets
- 3/8" FPT Outlet and Bypass
- Forged-Bronze Body
- Stainless-Steel Plunger and Seat Valve
- Compact Design
- Weight: 14.2 oz.

PART NO.	MODEL NO.	GPM	PSI
8.712-737.0	VS220	6.3	3600
8.901-057.0	Repair Kit		

**PRESSURE RELIEF VALVES - VS 500, HIGH PSI**



- PSI Max: 8100
- Rated PSI: 7250
- GPM: 21
- Suitable to be utilized as a safety valve
- Temperature: 195°F
- Internals: Stainless-steel
- Brass Body and Fittings
- 1/2" FPT Inlet and 3/8" FPT Bypass
- Weight: 14.2 oz.

PART NO.	MODEL NO.	GPM	PSI
8.712-757.0	VS 500	21	8100

**REGULATING RELIEF VALVE**

Economical replacement for paraplate BR5 series.



- Adjustable Pressure: 200-2000 PSI
- GPM: 7
- Temperature: 200°F
- 3/8" FPT Inlet, Outlet and Bypass
- Flow-Thru Design for Smooth Operation
- Machined-Brass Body and Knob
- Stainless-Steel Plunger and Seal

PART NO.	DESCRIPTION	GPM	PSI
8.712-625.0	Relief Valve	7	200-2000
8.900-042.0	Repair Kit		

**UNLOADER VALVES - MOUNTING BLOCK**



End vibrator-caused fitting failure.



- GPM: 12
- Mounting Hardware Included
- Machine Block Brass or Steel

PART NO.	DESCRIPTION	MATERIAL	PSI
8.904-568.0	3/8" x 3/8"	Brass	5500
8.904-567.0	1/2" x 1/2"	Brass	5500
9.802-870.0	3/8" x 3/8"	Steel	
9.802-871.0	1/2" x 1/2"	Steel	





## CHEMICAL INJECTORS - AMERIMAX SERIES



The higher rate injector. Our best seller!



- PSI: 3500
- Brass Housing
- Stainless-steel Orifice & Spring
- Fully Adjustable Metering Valve
- 3/8" MPT Inlet, Outlet
- 1/4" Hose Barb

PART NO.	DESCRIPTION	GPM	PSI
<b>STANDARD</b>			
8.904-192.0	"0"	1.0-2.0	3500
8.904-193.0	"1"	2.0-3.0	3500
9.803-998.0	"2"	3.0-5.0	3500
8.904-194.0	"3"	5.0-8.0	3500
8.900-040.0	Repair Kit Stainless-steel Check Ball		
<b>"ACID" INJECTOR WITH SPECIAL INLET CHECK VALVE</b>			
8.904-201.0	"0A"	1.0-2.0	3500
8.904-202.0	"1A"	2.0-3.0	3500
8.904-203.0	"2A"	3.0-5.0	3500
8.904-204.0	"3A"	5.0-8.0	3500
8.700-536.0	Ceramic Ball for 8.904-203.0		
8.900-041.0	Acid Repair Kit*		

\*Ceramic Check Ball

## CHEMICAL INJECTORS - STAINLESS-STEEL



- PSI: 5000
- Stainless-Steel

PART NO.	DESCRIPTION	GPM	PSI
9.802-217.0	Non-Adjustable, Injector Only	3.0-5.0	5000
9.802-226.0	Complete Injector Assembly, with Hose & Filter	3.0-5.0	5000

## CHEMICAL METERING VALVES - ST-61



- Max Temperature: 140°F
- GPM: .27
- 1/4" Hose Barb
- Teflon® Seals
- Glass-Filled Polyamide Body and Valve Parts
- Adjusts From Off to Full Flow
- Snap-on attachment to ST-60, ST-62, ST-261/1

PART NO.	DESCRIPTION
8.710-777.0	ST-61, 1/4" Hose Barb, Teflon® Seals

## CHEMICAL INJECTORS - AMERIMAX SERIES - QUICK-COUPLED ASSEMBLIES



Assembled for added convenience - quick couplers to unloader outlet and quick couplers hose to injector outlet.



- Top quality quick couplers: 3/8" Plug Inlet, 3/8" Socket Outlet
- 6" industrial-grade poly-braid reinforced tubing (will not collapse, resists crimping, high-chemical tolerance)
- Heavy-duty brass chemical filter with check valve prevent loss of prime

PART NO.	DESCRIPTION	GPM
<b>AMERIMAX "QC"</b>		
8.904-195.0	Quick-Coupled "0"	1.0-2.0
8.904-196.0	Quick-Coupled "1"	2.0-3.0
8.904-197.0	Quick-Coupled "2"	3.0-5.0
8.904-199.0	Quick-Coupled "3"	5.0-8.0
8.900-040.0	Repair Kit Stainless-steel Check Ball	
<b>AMERIMAX ACID "QC"</b>		
8.904-205.0	Quick-Coupled "0A"	1.0-2.0
8.904-206.0	Quick-Coupled "1A"	2.0-3.0
8.904-207.0	Quick-Coupled "2A"	3.0-5.0
8.904-208.0	Quick-Coupled "3A"	5.0-8.0
8.900-041.0	Acid Repair Kit*	

\*Ceramic Check Ball

## CHEMICAL INJECTORS - ST-60 SERIES



Requires ST-61 Metering Valve to regulate the chemical injection rate.



- Forged-Brass Body
- Compact Size
- PSI: 3600
- Siphon Rate: 10:1
- 3/8" MPT Inlet
- 3/8" FPT Outlet

PART NO.	DESCRIPTION	GPM	ORIFICE
8.710-476.0	ST 60/0	1.50-2.25	1.8 mm
8.710-477.0	ST-60/1	2.25-3.25	2.1 mm
8.710-478.0	ST-60/2	3.25-5.00	2.4 mm
8.701-648.0	Repair Kit with Barb-"F"		



## CHEMICAL INJECTORS - ST-64, UP STREAM



Apply soap at high pressure. Restricts waterflow to create suction. Used on Pressure Pro Equipment as well as other major manufacturers.

- PSI: 140
- Temperature: 160°F
- 3/4" FGH Inlet, 3/4" MGH Outlet
- Chemical strainer and 4' PVC tubing included
- Adjustable with ST-61 Metering Valve
- Locking Waterflow Adjustment



PART NO.	MODEL NO.	GPM	PSI
8.710-482.0	ST-64 Up Stream Injector	1.5-4.0	140
8.710-483.0	ST-64 Up Stream Injector	4.0-7.0	140

## CHEMICAL INJECTORS - ROBOKIM

- Rated PSI: 3200  
Max PSI: 3500
- Max Temperature: 210°F
- 3/8" MPT Inlet, Outlet
- 1/4" Hose Barb
- Stainless-Steel Orifice
- Stainless-Steel Inlet Check Valve Components



PART NO.	MODEL NO.	GPM	PSI	PSI
<b>ROBOKIM WITH PLASTIC METER KNOB</b>				
8.710-497.0	Chemical Injector "0"	2.1-2.9	3500	2.0 mm
8.710-498.0	Chemical Injector "1"	2.9-4.0	3500	2.2 mm
8.710-499.0	Chemical Injector "2"	4.0-5.5	3500	2.5 mm
8.710-500.0	Chemical Injector "3"	5.5-10.8	3500	2.75 mm
8.704-708.0	Repair Kit, RoboKim			

## CHEMICAL INJECTORS - ST-62 VARIABLE



Flow orifice adjusts for machines from 2-8 GPM. Requires ST-61 to regulate chemical injection rate.



- Max PSI: 36500
- GPM: 2.0 - 8.0
- Forged-Brass Body
- 3/8" FPT Inlet & Outlet

PART NO.	MODEL NO.	GPM	PSI
8.710-485.0	ST-62	8	3600
8.701-648.0	Repair Kit with Barb-"F"		

## CHEMICAL INJECTORS - ROBOKIM QUICK-COUPLED ASSEMBLIES



- Quick-Couplers:  
3/8" QC Plug Inlet  
3/8" QC Socket Outlet
- 6" industrial-grade poly-braid reinforced tubing
- AP brass chemical filter with stainless-steel check valve

PART NO.	DESCRIPTION	GPM
<b>ROBOKIM "QC" WITH PLASTIC KNOB</b>		
8.904-209.0	Chemical Injector "0"	2.1-2.9
8.904-210.0	Chemical Injector "1"	3.0-4.0
8.904-211.0	Chemical Injector "2"	4.0-5.5
8.904-212.0	Chemical Injector "3"	5.5-10.8
<b>ROBOKIM "QC" WITH BRASS KNOB</b>		
8.904-217.0	Chemical Injector "0"	2.1-2.9
8.904-218.0	Chemical Injector "1"	3.0-4.0
8.904-219.0	Chemical Injector "2"	4.0-5.5
8.904-220.0	Chemical Injector "3"	5.5-10.8

## CHEMICAL INJECTORS - HI-LO

May be used on high or low side of pump. Adjustable flow orifices plus adjustable chemical valves. Standard features similar to ST-62.

- Performance Range:
  - Low Side/Upstream: PSI: 10-120, GPM: .5-3.5
  - High Side/Downstream: PSI: 3500, GPM: 2.0-8.0
- Max Temperature: 180°F
- Machined-Brass Body
- 3/8" FPT Inlet, Outlet



PART NO.	MODEL NO.	GPM	PSI
8.710-486.0	Hi / Lo Injector with Meter Valve	2.0-8.0	3500
8.710-487.0	without Chemical Adjust	2.0-8.0	3500
8.700-290.0	Repair Kit		
8.900-044.0	Seal Kit		

## CHEMICAL INJECTORS - 400 SERIES

The injector of choice.



- PSI: 3200
- Temperature: 200°F
- Forged-Brass Housing
- Teflon® Valve Seat
- 3/8" Inlet, Outlet (3 Configurations)
- Renewable Orifices and Check Valve
- Options Include: Quick-Coupled, Stainless-Steel Orifices, Acid-Resistant Check
- Weight: 5 oz.



### ORIFICE SELECTION

ORIFICE DIA.	DESCRIPTION	GPM / FLOW RATE	PSI
1.6 MM	3/8" Inlet / Outlet	1.5-2.7	3200
1.8 MM	3/8" Inlet / Outlet	2.0-3.6	3200
2.1 MM	3/8" Inlet / Outlet	2.7-4.9	3200
2.3 MM	3/8" Inlet / Outlet	3.3-6.0	3200

### ADJUSTABLE INJECTORS, PRECISE NEEDLE-METERING VALVE

ORIFICE SIZE	M X M PART NO.	M X F PART NO.	F X M PART NO.
<b>BRASS BODY</b>			
1.6	8.710-541.0	8.710-549.0	8.710-559.0
1.8	8.710-535.0	8.710-543.0	8.710-551.0
2.1	8.710-537.0	8.710-545.0	8.710-554.0
2.3	8.710-539.0	8.710-547.0	8.710-557.0
<b>BRASS BODY / STAINLESS-STEEL INSERT</b>			
1.6	8.710-542.0	8.710-550.0	8.710-560.0
1.8	8.710-536.0	8.710-544.0	8.710-552.0
2.1	8.710-538.0	8.710-546.0	8.710-556.0
2.3	8.710-540.0	8.710-548.0	-
<b>BRASS BODY / ACID-RESISTANT</b>			
1.6	8.904-230.0	8.904-238.0	-
1.8	8.904-224.0	8.904-232.0	-
2.1	8.904-226.0	8.904-234.0	8.904-242.0
2.3	8.904-228.0	8.904-236.0	-
<b>BRASS BODY / STAINLESS-STEEL INSERT / ACID-RESISTANT</b>			
1.6	-	-	8.904-246.0
1.8	8.904-225.0	8.904-233.0	8.904-241.0
2.1	8.904-227.0	8.904-235.0	8.904-243.0
2.3	8.904-229.0	8.904-237.0	-

PART NO.	DESCRIPTION
<b>REPAIR KITS INCLUDE CHECK BALL, SPRING, SEAT AND O-RING</b>	
8.900-769.0	Standard Kit
8.900-770.0	Acid Kit

### CHEMICAL INJECTORS - STAINLESS-STEEL



- PSI: 5500
- Temperature: 190°F
- 3/8" MPT Inlet, Outlet
- 1/4" Hose Barb
- 1.8 mm Orifice
- Weight 8.0 oz.
- High Draw: 20%

PART NO.	MODEL NO.	GPM	PSI
9.112-213.0	Chemical Injector	2.0-3.0	5500

### CHEMICAL INJECTORS - 505 SERIES STAINLESS-STEEL



All metal parts are stainless-steel



- PSI: 5650
- GPM: 8.0
- Temperature Max: 195°F
- 3/8" Inlet, Outlet
- Premier Type Injector
- Teflon® O-Rings

PART NO.	MODEL NO.	GPM	PSI
8.710-586.0	Stainless-steel Injector 1.8	2.0-2.6	5650
8.710-587.0	Stainless-steel Injector 2.1	2.6-4.0	5650
8.710-588.0	Stainless-steel Injector 2.3	4.0-5.3	5650
8.704-027.0	Repair Kit		

### CHEMICAL INJECTORS - ADJUSTABLE, WITH QUICK-CONNECT



- PSI: 3500
- Temperature Max: 200°F
- 3/8" M Plug Inlet
- 3/8" F Coupler Outlet
- 1/4" Hose Barb

PART NO.	MODEL NO.	GPM
8.710-502.0	Adjustable QC - 1.8 mm	2.0-3.0
8.710-503.0	Adjustable QC - 2.1 mm	3.0-5.0
8.710-504.0	Adjustable QC - 2.3 mm	5.0-8.0

#### ACID INJECTORS

8.904-221.0	Adjustable QC - 1.8 mm	2.0-3.0
8.904-222.0	Adjustable QC - 2.1 mm	3.0-5.0
8.904-223.0	Adjustable QC - 2.3 mm	5.0-8.0
8.701-187.0	Injector Repair Kit	
8.900-087.0	Injector Acid Kit	

### CHEMICAL INJECTORS - BRASS

All metal parts are brass



- PSI: 4000
- Temperature Max: 190°F
- 3/8" Inlet, Outlet
- Premier Type Injector
- EPDM O-Ring

PART NO.	MODEL NO.	GPM	PSI
8.710-505.0	Brass Injector 1.8	2.0-2.6	4000
8.710-506.0	Brass Injector 2.1	2.7-4.0	4000
8.710-507.0	Brass Injector 2.3	4.0-5.3	4000
8.704-028.0	Repair Kit		

### CHEMICAL INJECTORS / PRESSURE REDUCER - EXTRACT-A-FLOW

"Low side" chemical injector that regulates inlet pressure to maintain consistent chemical ratio.



- GPM: Up to 6.0
- 1/2" FPT I/O Ports
- 1/4" Hose Barb Chemical Inlet
- +2% Injection Ratio Variation

PART NO.	DESCRIPTION
8.711-162.0	Weep Seat*
8.711-160.0	Non-Weep
8.711-161.0	With Switch**
8.904-389.0	Hose Barb with Viton Check
8.904-390.0	Hose Barb with Buna Check

\*Weep Seat allows pump to self-prime

\*\*With burner control switch (9.802-362.0) automatically turns burner off when water flow stops

### FLOAT VALVES - ADJUSTABLE, BRONZE



- Temperature Max: 180°F
- Cast-Bronze Body
- Adjustable Float Arm
- Live Rubber Stopper

PART NO.	THREAD	STEM	GPM AT 40 PSI
8.710-045.0	1"	1/4"-20	47

#### REPAIR PARTS FOR ADJUSTABLE VALVES

8.700-475.0	Long Arm*
8.700-476.0	Short Arm*
8.700-477.0	Thumb Screw*
8.700-479.0	3/8" and 1/2" Plunger

\*Fits 3/8", 1/2" and 3/4" valve only

Note: Float valve requires stem and float



### FLOAT VALVES - STEMS



PART NO.	LENGTH	THREAD
<b>BRASS</b>		
9.802-157.0	8"	1/4" - 20
8.710-051.0	10"	1/4" - 20
<b>STAINLESS-STEEL</b>		
8.710-047.0	8"	1/4" - 20 x 5/16" - 18

Parts for other float valves also available

### FLOAT VALVES - BALLS, COPPER & PLASTIC



PART NO.	LENGTH	THREAD
<b>COPPER</b>		
8.710-061.0	4" x 5"	1/4"-20
8.710-052.0	5"	1/4"-20
8.710-053.0	6"	1/4"-20
<b>PLASTIC</b>		
8.710-057.0	6"	1/4"-20
8.710-059.0	8"	1/4"-20
9.802-061.0	4" x 5"	1/4"-20

Parts for other float valves also available

### FLOAT VALVES - PA BRASS ASSEMBLY

Used on Pressure Pro Equipment as well as other major equipment manufacturers.



- Max GPM: 7.0
- Max PSI: 145
- Temperature: 140°F
- 3/8" BSP-M Inlet
- Brass Body
- Positional / Adjustable Arm

PART NO.	DESCRIPTION	MATERIAL	TEMP
8.710-042.0	Float Valve	Brass Body	140°F
8.704-204.0	Repair Kit		

### FLOAT VALVES - ST-8, BRASS ASSEMBLY



Complete assembly includes valve, stem and float.



- GPM: 5.0
- Temperature: 175°F
- 1/2" FPT Inlet
- Brass Housing with Polyamide Cover

PART NO.	DESCRIPTION	GPM	TEMP
8.710-031.0	ST-8	5.0	175°F
8.710-033.0*	MPT Adapter Kit for ST-8		

\*Double MPT nipple, sealing washer and lock nut

### FLOAT VALVES - BRASS FLOAT WITH BALL & STEM



- Inlet PSI Max: 142
- GPM: 7.1 at PSI: 28
- 1/2" MPT Inlet
- Temperature: 140°F
- Positive Soft Buna / Brass Shut-Off
- Adjustable Float Ball Settings
- Inlet Nut and Washer Seal Provided

PART NO.	DESCRIPTION	PSI MAX	TEMP
8.710-037.0	Valve Complete	142	140°F
8.704-092.0	Repair Kit		

### FLOAT VALVES - DIAPHRAGM



- PSI: 142
- GPM: 7.86 at PSI: 28
- GPM: 6.68 at PSI: 14
- Temperature: 140°F
- 3/8" MPT Inlet
- Requires only 6.5" x 3" inside tank
- All-Plastic Snap-On Float
- Positive Shutoff Diaphragm Style
- Inlet Screen, Tank Gasket and Nut Included

PART NO.	DESCRIPTION	PSI	TEMP
8.710-030.0	Float Valve Complete	142	140°F

### FLOAT VALVES - VERTICAL



- GPM: 8.0 at PSI: 150
- Temperature: 140°F
- 1/2" MPT Inlet
- Inlet Nut and Washer Seal Provided

PART NO.	DESCRIPTION	TEMP
9.802-185.0	Vertical Float Tank Valve, 1/2" MPT Inlet	140°F

### FLOAT VALVES - HUDSON



- PSI: 0-130
- Temperature: 90 & 150°F
- No External Moving Parts
- No Float Ball or Arm
- All Plastic, Nylon, Rubber and Stainless-Steel
- 1" Inlet - Easy Installation
- Automatic Anti-Siphon
- Flow Capacity 80% of Supply: GPM:40 at PSI: 40

PART NO.	DESCRIPTION	PSI	TEMP
8.710-035.0	1" Hudson Float Valve, 90°	0-130	90°F
8.710-036.0	1" Hudson Float Valve, 150°	0-130	150°F

### FLOAT VALVES - KERICK



#### FLOW RATE FOR 1/2" VALVE

- PSI: 20 at GPM: 7.7
- PSI: 30 at GPM: 9.1
- PSI: 40 at GPM: 10.5
- PSI: 50 at GPM: 11.4
- PSI: 60 at GPM: 12.5

#### FLOW RATE FOR 3/4" VALVE

- PSI: 30 at GPM: 13
- PSI: 60 at GPM: 16.5

PART NO.	DESCRIPTION	ORIFICE
8.749-328.0	1/2" Float Valve	.25"
8.749-329.0	3/4" Float Valve	.30"

### FLOAT VALVES - BRASS

- MTM / Veloci
- Includes Filter and Pipe

PART NO.	DESCRIPTION
8.754-085.0	Float Valve 3/4" M with Filter and Pipe

### CHECK VALVES - SWING ACTION, LOW PSI



Retain prime on pumps with low-lift capability.



- PSI: 150
- Brass Body, Swing (flapper) Action
- FPT Inlet, Outlet
- Gravity Seal, No Spring Pressure

PART NO.	DESCRIPTION	PSI
8.709-378.0	1/2", FPT Inlet / Outlet, Gravity Seal	150
8.709-379.0	3/4", FPT Inlet / Outlet, Gravity Seal	150
8.709-380.0	1", FPT Inlet / Outlet, Gravity Seal	150
8.709-381.0	1-1/4", FPT Inlet / Outlet, Gravity Seal	150

### CHECK VALVES - STAINLESS-STEEL, HIGH PSI

Holds pump prime without overloading pump suction.



- PSI: 6500
- Rated PSI: 5800
- Temperature: 195°F
- Female x Female
- Weight: 2.0 oz.

PART NO.	DESCRIPTION	FLOW RATE	PSI
8.709-361.0	1/4" F x F	6.1	6500
8.709-362.0	3/8" F x F	10.5	6500



### CHECK VALVES - 460 SERIES, HIGH PSI

Holds pump prime without overloading pump suction



8.709-356.0

- Max PSI: 2500
- Buna Seals

8.709-357.0

- Stainless-Steel Check Ball & Spring
- Machined-Brass Body

8.709-358.0

PART NO.	DESCRIPTION	CRACKING PRESSURE
<b>2500 PSI MINIATURE BALL CHECK</b>		
8.709-356.0	1/4", M x F	1 PSI
8.709-357.0	1/4", M x M	3 PSI
<b>3000 PSI STAINLESS GUIDED BALL AND QUAD RING SEAT</b>		
8.709-358.0	1/4", F x F	1 PSI
8.709-359.0	3/8", F x F	3 PSI

### CHECK VALVES - SPRING LOADED, HIGH PSI

Holds pump prime without overloading pump suction.



- PSI: 1200
- Max Temperature: 250°F
- Cracking Pressure PSI: 1
- Machined-Brass Body
- Stainless Steel Springs
- Poppet Seal

PART NO.	DESCRIPTION	MATERIAL
8.709-351.0	1/4", F x F	Machined Brass Body
8.709-352.0	3/8", F x F	Machined Brass Body
8.709-353.0	1/2", F x F	Machined Brass Body
8.709-354.0	3/4", M x M	Machined Brass Body

### CHECK VALVES - SPRING LOADED, LOW PSI

Holds pump prime without overloading pump suction



- PSI: 150
- Max Temperature: 250°F
- Machine-Cast Brass Bodies
- FPT x FPT
- Mount Horizontal or Vertical

PART NO.	DESCRIPTION	PSI	TEMP
8.709-384.0	1/2"	150	250°F
8.709-385.0	3/4"	150	250°F
8.709-386.0	1"	150	250°F

### CHECK VALVES / BACKFLOW PREVENTOR - T533 MODEL, VACUUM BREAKER

Protects water supply from harmful chemical backflow - will not allow "spike" pressure to push chemicals into supply line. Now required by many city and state regulations.



- Max PSI: 125
- Max Temperature: 180°F
- Machined-Brass Housing, Chrome Plated Finish
- Plastic Diaphragm Check
- 3/4" Female Garden Hose Inlet (with Lock Screw)
- 3/4" Male Garden Hose Outlet

PART NO.	DESCRIPTION	MATERIAL
8.705-039.0	Backflow Preventor	Machined Brass Housing

### CHECK VALVES - PVC, LOW PSI

Holds pump prime without overloading pump suction.



- PSI: 125
- Cracking Pressure PSI: 1
- Temperature: 180°F
- Choice of Connects
- PVC Plastic Body
- Stainless-Steel Ball Check
- Designed for Harsh Chemical Applications

PART NO.	DESCRIPTION	PSI	TEMP
8.709-366.0	1/4" MPT x 1/4" Barb	125	180°F
8.709-367.0	1/4" Barb x 1/4" MPT	125	180°F
8.709-369.0	1/4" Barb x 1/4" Barb	125	180°F
8.709-370.0	3/8" Barb x 3/8" Barb	125	180°F
8.709-373.0	1/2" Barb x 1/2" Barb	125	180°F

\*8.709-373.0 has Viton Seals



**BALL VALVES - STAINLESS-STEEL, LOW PSI**



- PSI: 2000 at Temperature: 180°F
- PSI: 1000 at Temperature: 300°F
- PSI: 300 at Temperature: 350°F
- Full-Flow Ports
- Investment Cast Process
- Two-Piece 316 Stainless Bodies
- Glass-Filled Teflon® Seals

PART NO.	DESCRIPTION
8.709-265.0	1/4" F x F, Glass-filled Teflon® Seals
8.709-266.0	3/8" F x F, Glass-filled Teflon® Seals
8.709-268.0	1/2" F x F, Glass-filled Teflon® Seals
8.709-269.0	3/4" F x F, Glass-filled Teflon® Seals

**BALL VALVES - FORGED-BRASS, LOW PSI**



- PSI: 600
- Temperature: 180°F
- Forged-Brass Body
- Full-Flow Ports
- Teflon® PTFE Seals

SIZE	M X F PART NO.	F X F PART NO.	M X M PART NO.
1/4"	8.709-249.0	8.709-250.0	-
3/8"	8.709-252.0	8.709-253.0	8.709-254.0
1/2"	8.709-255.0	8.709-256.0	8.709-257.0
3/4"	8.709-258.0	8.709-259.0	8.709-260.0
1"	8.709-261.0	8.709-262.0	8.709-263.0

**BALL VALVES - MINI, LOW PSI**



- PSI: 600
- 180° Handle Movement
- Forged-Brass Body

SIZE	M X F PART NO.	F X F PART NO.	M X M PART NO.
1/8"	8.709-208.0	8.709-209.0	-
1/4"	8.709-211.0	8.709-212.0	8.709-213.0
3/8"	8.709-216.0	-	-

### BALL VALVES - NICKEL-PLATED BRASS, LOW PSI



- Threaded FPT Connects
- Chrome-Plated Ball
- Full-Flow Bore
- Seats and Seals have Glass-Filled Teflon®
- Nickel Plated Brass Body

PART NO.	DESCRIPTION	PSI
8.709-242.0	1/4", Chrome-plated Ball, Full-flow Bore	710
8.709-243.0	3/8", Chrome-plated Ball, Full-flow Bore	710
8.709-244.0	1/2", Chrome-plated Ball, Full-flow Bore	710
8.709-245.0	3/4", Chrome-plated Ball, Full-flow Bore	570
8.709-246.0	1", Chrome-plated Ball, Full-flow Bore	570
8.709-247.0	1-1/4", Chrome-plated Ball, Full-flow Bore	430
8.709-248.0	1-1/2", Chrome-plated Ball, Full-flow Bore	430
8.709-264.0	2", Chrome-plated Ball, Full-flow Bore	360

### BALL VALVES - RKH SERIES - STAINLESS-STEEL, HIGH PSI



- 316 Stainless-Steel Body, Ball and Stem
- Viton O-Rings
- Delron Ball Seats
- Full Port

PART NO.	FPT	PSI
8.709-277.0	3/8" x 3/8"	5880
8.709-280.0	1/2" x 1/2"	5880
8.709-283.0	3/4" x 3/4"	5154
8.709-286.0	1" x 1"	5154

### BALL VALVES - SHUT-OFF, HIGH PSI



- Max PSI: 3000
- Max Temperature: 176°F
- Nickel Plated Brass Body

PART NO.	DESCRIPTION	PSI
8.753-959.0	3/8 FPT x 3/8 FPT	3000
9.113-462.0 <small>NEW</small>	3/8" FPT x FPT	5000

### BALL VALVES - BKH SERIES, HIGH PSI



- Rugged Carbon Steel Construction
- 2-Way
- NPT (F x F) Threads
- Blow-Out Proof Stems
- Delrin Ball Seats
- Buna O-Rings

PART NO.	FPT	PSI
8.709-274.0	1/4" x 1/4"	7350
8.709-276.0	3/8" x 3/8"	7350
8.709-279.0	1/2" x 1/2"	7350
8.709-282.0	3/4" x 3/4"	5880
8.700-270.0	Replacement Handle (fits all sizes above)	
8.700-271.0	Replacement Screw for Handle	

### BALL VALVES - PVC, LOW PSI

Great for chemical on / off flow control.



- PSI: 125
- Temperature: 140°F
- Flag Handle
- PVC and Nitrile Material
- Chemical and Impact Resistant

PART NO.	DESCRIPTION	PSI
8.709-214.0	1/4" Panel Mtg, Barb x Barb	125
8.709-219.0	1/4" In-line, Barb x Barb	125
8.709-220.0	3/8" In-line, Barb x Barb	125

### BALL VALVES - STAINLESS-STEEL, LOW PSI, ONE PIECE



- PSI: 800 at Temperature: 300°F
- PSI: 400 at Temperature: 350°F
- Standard Port
- 316 Stainless-Steel Body
- Suitable for Steam

PART NO.	FPT	MATERIAL
8.709-287.0	1/4" x 1/4"	316 Stainless-steel Body
8.709-288.0	3/8" x 3/8"	316 Stainless-steel Body
8.709-290.0	3/4" x 3/4"	316 Stainless-steel Body

### BALL VALVES - 2940/3830 MINI SERIES, LOW PSI



- PSI: 147 Working Pressure
- Nickel Plated Brass
- Brass Housing-Hex Bar
- Compact Knob Operation
- Designed to fit tight quarters
- Telfon® Seals

PART NO.	DESCRIPTION
8.709-270.0	Series 3830 - Nickel Plated Brass, 1/8" x 1/8" FPT
8.709-271.0	Series 3830 - Nickel Plated Brass, 1/4" x 1/4" FPT
8.709-272.0	Series 2940 - Brass, 3/8" x 3/8" FPT
8.709-273.0	Series 2940 - Brass, 1/2" x 1/2" FPT

### BALL VALVES - T-601 SERIES COMPACT PVC, LOW PSI



- PSI: 150 Working Pressure
- Temperature: 140°F
- FPT Thread Both Ends
- Easy-Turn Handle
- EPDM Seals - White Body

PART NO.	FPT
8.709-233.0	1/4" x 1/4"
8.709-234.0	1/2" x 1/2"
8.709-235.0	3/4" x 3/4"
8.709-236.0	1" x 1"
8.709-237.0	1-1/4" x 1-1/4"
8.709-238.0	1-1/2" x 1-1/2"
8.709-239.0	2" x 2"

### BALL VALVES - MODEL 727, 3 WAY



- PSI Max: 500
- Temperature Max: 180°F
- Telfon® Seat & Stainless Handle Screw
- Buna Seals
- Brass

PART NO.	DESCRIPTION	PSI	TEMP
8.709-207.0	1/4" M x F x F	500	180°F

### BALL VALVES - 454 SERIES, POLYPROPYLENE, LOW PSI

Full port reinforced polypropylene body for strength & chemical resistance.



8.709-222.0    8.709-228.0

- Max PSI: 240 Working Pressure
- Teflon Seats for smooth operation & proper sealing.
- Double EPDM O-Rings in Stem for "No Leak"
- Threaded Mounting Brass Inserts on 1-1/4" - 2" Sizes
- 8mm Mounting Inserts

PART NO.	FPT
<b>TWO-WAY BALL VALVES</b>	
8.709-222.0	1/2" x 1/2"
8.709-223.0	3/4" x 3/4"
8.709-224.0	1" x 1"
8.709-225.0	1-1/2" x 1-1/2"
8.709-226.0	2" x 2"
<b>THREE-WAY BALL VALVES</b>	
8.709-227.0	1/2" x 1/2" x 1/2"
8.709-228.0	3/4" x 3/4" x 3/4"
8.709-229.0	1" x 1" x 1"
8.709-230.0	1-1/4" x 1-1/4" x 1-1/4"
8.709-231.0	1-1/2" x 1-1/2" x 1-1/2"
8.709-232.0	2" x 2" x 2"

### CHEMICAL METERING VALVES - FLOW SELECTOR, 3 & 4 WAY

3-way and 4-way lever control with brass body.



- 3-Way
- Plumb for 2 Inlets and 1 Outlet or 1 Inlet and 2 Outlets
- 4-Way
- Plumb for 3 Inlets and 1 Outlet or 1 Inlet and 3 Outlets
- Rated Temperature: 180°F

PART NO.	DESCRIPTION	TEMP
8.710-108.0	1/4" FPT 3-Way	180°F
8.710-110.0	3/8" FPT 3-Way	180°F
8.710-113.0	1/4" FPT 4-Way	180°F
8.710-114.0	3/8" FPT 4-Way	180°F

## CHEMICAL METERING VALVES - SERIES 28, FLOW CONTROL



- PSI: 150
- Rated Temperature: 175°F
- Forged-Brass, Nickel-Plated Body
- Panel Mtg in 17/32" Hole
- Compact Size
- Double-Stem Seal

PART NO.	DESCRIPTION	TEMP	PSI
8.710-775.0	1/4", FPT Inlet/Outlet	175°F	150
8.710-776.0	3/8", FPT Inlet/Outlet	175°F	150

## CHEMICAL METERING VALVES - BRASS



- PSI: 400 - 450
- Rated Temperature: 100°F
- 1/4" Inlet, Outlet
- Easy-Grip, Fluted Plastic Handle with Pointer
- Brass Body, Viton gland seal eliminates air leaks
- Panel Mount 11/16" or 3/4" Hole
- Extremely Compact T-Style

PART NO.	DESCRIPTION	PSI
8.710-773.0	"T" 1/4" F x F, Forged	440
9.802-188.0	"L" 1/4" M x M	440

## CHEMICAL METERING VALVES - SERIES 28, FLOW CONTROL



9.802-187.0



9.802-532.0

- PSI: 4000
- GPM: 6
- 1/4" Inlet, Outlet
- Adjusts from off to full flow
- 9.802-187.0 has presettable limiting orifice
- Forged-Brass Body

PART NO.	DESCRIPTION	PSI
8.710-771.0	Flow Control	4000
9.802-187.0	Flow Control with Bottom 4000 Locking Adjustment	
9.802-532.0	Valve, Less Solenoid	4000

## CHEMICAL METERING VALVES - FLOW CONTROL



The valve that "seals" (will not suck air).



- PSI: 3500
- Rated Temperature: 195°F
- 28" Vacuum - No Leak
- Viton Gland Seal Isolates Metering Threads from Solution
- Stainless-Steel Needle, Brass Seat
- 1/4" FPT Ports
- Heavy-Duty Brass Bar Stock Body
- Panel Mounts 5/8" Hole
- Large Easy-Grip Four-Lobe Handwheel
- Aluminum or Poly Available

PART NO.	DESCRIPTION	PSI
8.904-362.0	Metering Valve, Aluminum Knob	3500
8.904-361.0	Metering Valve, Poly Knob	3500
8.740-083.0	Replacement Knob	

## CHEMICAL METERING VALVES - DUAL - ST-66 MODEL

Chemical flow can be metered and shut off remotely from the injector. With two inlets, it also allows switching from one solution to another.



- Double-Metering Dial with Center OFF
- Panel Mount in Single 5/8" Hole
- Two Input Barbs - for Different Chemicals to Single Outlet Barb

PART NO.	DESCRIPTION	PANEL MOUNTING
8.710-779.0	ST-66	Single 5/8" Hole

## THERMAL RELIEF VALVE/PUMP PROTECTOR- COMPACT



- With and W/out 90° Hose Barb

PART NO.	SIZE	90° BARB	"TRIP" TEMP
8.712-544.0	1/4" MPT	No	145°F
8.712-545.0	3/8" MPT	No	145°F
9.802-181.0	3/8 MPT	Yes	145°F
9.804-025.0	1/4" MPT	Yes	145°F
8.707-250.0	3/8 MPT	Yes	190°F
9.803-670.0	1/2" MPT	Yes	190°F
8.707-256.0	1/2" MPT	Yes	145°F

### REGULATOR VALVE - STEAM

For "combo" hot pressure washer / steamer units. The single-turn on / off diverter valve bypasses pump flow to reduce water flow to the coil, creating steam in place of normal hot water.



- PSI: 4000
- Rated Temperature: 175°F  
Max Temperature: 300°F
- 1/4" MPT Inlet, Outlet
- Panel Mount in 11/16" or 3/4" Hole
- Machined-Brass Body
- Easy-Grip Plastic Knob

PART NO.	ORIFICE (MM)	PSI
8.711-263.0	0.8	4000
8.904-406.0	1.2	4000
8.904-407.0	1.5	4000
8.904-408.0	1.8	4000
8.904-409.0	2.0	4000

### THERMAL RELIEF VALVE/ PUMP PROTECTOR



A must for any pump that might ever be left in bypass mode (unloading) for more than 15 seconds. Protects the pump from overheating caused by recirculating water.



- Installs in Bypass Line
- Automotive Style Wax Element
- Automatically Resets at Cool Down to 115°F+
- No Adjustment Required
- 1/8" FPT Side Discharge
- PSI: 125 Inlet Pressure
- GPM: 2.5

PART NO.	INLET	GPM	"TRIP" TEMP
8.904-565.0	3/8" MPT	2.5	140°F
8.904-566.0	1/2" MPT	2.5	140°F
8.723-943.0	1/2" MPT	2.5	165°F

### RUPTURE DISKS



- Temperature: 225°F
- 3/8" Inlet x 1/2" MPT Outlet
- Prevents dangerous thermal expansion of water in the coil
- Ensures operator safety

PART NO.	DESCRIPTION	MAX PSI
9.802-192.0	Assembly	7000
8.707-381.0	Assembly	8500

### THERMAL RELIEF VALVE/PUMP PROTECTOR - TRV



- PSI: 145
- Opens Temperature: 135°F
- Low Profile
- Brass Body
- Plastic-Covered Barb

PART NO.	DESCRIPTION	PSI
8.712-547.0	3/8" Inlet, Low Profile, Brass Body	145
8.712-548.0	1/2" Inlet, Low Profile, Brass Body	145

### PRESSURE RELIEF VALVES



Commonly referred to as a Pop-Off Valve.



- Temperature: 160°F
- GPM: 10
- MPT Inlets x End Vent Outlets
- Machined Brass
- Automatically Resets
- Prevents pressure overloads, protecting people and equipment

PART NO.	DESCRIPTION	MAX PSI
8.722-192.0	1/4", Silver Spring	1200
8.722-193.0	1/4", Red Spring	2400
8.722-194.0	1/4", Orange Spring	3600
8.722-190.0	3/8", Orange Spring	3600
9.802-191.0	3/8", Blue Spring	5000

### AIR VALVE - COIL BLOW OUT



Also good for water tank blowouts as well as blowing out irrigation lines.



- Threaded Connection
- 1/8" Brass Valve
- 1/8" Model is Stainless-Steel
- Valve Cap Included

PART NO.	DESCRIPTION
8.705-047.0	Stainless-steel, 1/8" MPT Connect
8.705-048.0	Lead Free Brass, 1/4" MPT Connect
8.902-426.0	Valve Assy, Water Blow-Out
8.707-314.0	Valve Assy, Water Tank Blow-Out

### FLOW METERS - VISI - FLOAT



- Installs in Bypass Line
- Automotive Style Wax Element
- Automatically Resets at Cool Down to 115°F+
- No Adjustment Required
- 1/8" FPT Side Discharge
- PSI: 125 Inlet Pressure
- GPM: 2.5
- 2" Scale

PART NO.	GPH	MATERIAL	METERING VALVE
8.710-097.0	.6-5	Brass	No
8.710-098.0	.6-5	Brass	Yes
8.710-101.0	2-10	Brass	No
8.710-102.0	2-10	Brass	Yes
8.710-099.0	.6-5	Stainless-steel	No
8.710-100.0	.6-5	Stainless-steel	Yes
8.710-104.0	2-10	Stainless-steel	No
8.710-105.0	2-10	Stainless-steel	Yes

Note: All flow measurements must be on low-pressure side of pump

### PRESSURE RELIEF VALVE - EASY-START, HIGH PSI



- Rated PSI: 4050  
Permissible PSI: 4500
- Temperature: 176°F
- GPM: 8.0
- 3/8" MPT Inlet
- Hose Barb Outlet (8 mm)
- Machined-Brass Body
- Stainless-Steel Spring and Ball

PART NO.	DESCRIPTION	GPM	PSI
8.709-867.0	Easy-Start Valve	8.0	4500

### PRESSURE GAUGES - PORT KIT



- PSI: 5000 Cold Water
- 1-3/4" Gauge
- 3/8" QC Socket
- 3/8" QC Plug

PART NO.	DESCRIPTION	QC SOCKET / PLUG
8.712-208.0	Pressure Gauge Kit	3/8" / 3/8"

### PRESSURE RELIEF VALVE - EASY-START, LOW PSI



- Temperature: 195°F
- Machined-Brass Housing
- GPM: 8.0
- Stainless-Steel Internals

PART NO.	DESCRIPTION	INLET / OUTLET	PSI
9.804-065.0	Easy-Start Valve	1/4" MPT, 1/8" FPT	5000
9.802-190.0	Easy-Start Valve	3/8" MPT, 1/8" FPT	5000
8.709-865.0	Easy-Start Valve	3/8" MPT, 1/4" Barb	4100
8.709-866.0	Easy-Start Valve	3/8" MPT, 1/8" FPT	3500
8.751-265.0	Easy-start Valve	3/8" MPT, 5/16" HB	5000
9.802-137.0	Hose Barb (only) - 1/4" Barb x 1/8" MPT		

### PRESSURE GAUGES - 100 SERIES PNEUMATIC



- Black Lacquered Steel Case
- Bronze Bourdon Tube
- Dry Gauge
- 1/4" NPT Brass Mounting Stem
- Accuracy + 3-2-3%

PART NO.	PRESSURE RANGE	MOUNTING STEM
<b>2" BOTTOM MOUNT</b>		
8.710-307.0	0-60	1/4" NPT Brass
8.710-308.0	0-100	1/4" NPT Brass
8.710-309.0	0-200	1/4" NPT Brass
8.710-310.0	0-300	1/4" NPT Brass

### PRESSURE GAUGE - FUEL / OIL



- PSI: 0-200
- Perfect for Testing Burner Pump Fuel Pressure
- Metal Housing
- 2" Bottom Mount, 1/4" NPSM

PART NO.	DESCRIPTION	PRESSURE RANGE
8.700-738.0	Fuel Oil Pressure Gauge	0-200 PSI

NOTE: NPSM - American National Straight Pipe Threads



**PRESSURE GAUGES - ABS, CORROSION-RESISTANT**



- 2-1/2", Bottom Mount
- Acid and Alkali Proof Plastic Case
- 1/4" NPT Brass Mounting Stem
- Accuracy, Dry: + 3-2-3%
- Accuracy, Filled: + 1.5%
- Bronze Bourdon Tube

PART NO.	PRESSURE RANGE	MOUNTING STEM
8.710-291.0	0-100 PSI	1/4" NPT Brass
8.710-293.0	0-200 PSI	1/4" NPT Brass
8.710-294.0	0-300 PSI	1/4" NPT Brass
8.710-295.0	0-1000 PSI	1/4" NPT Brass
8.710-296.0	0-2000 PSI	1/4" NPT Brass
8.710-297.0	0-3000 PSI	1/4" NPT Brass
8.710-299.0	0-5000 PSI	1/4" NPT Brass

**PRESSURE REGULATOR, WATER 2-WAY**



- PSI: 10 - 125
- 3/8" Valve
- Lowers city water pressure for better machine performance

PART NO.	DESCRIPTION	PSI
8.707-248.0	Pressure Regulator	10-125

**PRESSURE GAUGES - VACUUM - STAINLESS-STEEL**



- Black Lacquered Steel Case
- Bronze Bourdon Tube
- Dry Gauge
- 1/4" NPT Brass Mounting Stem
- Accuracy + 3-2-3%

PART NO.	DESCRIPTION
<b>2-1/2" BACK MOUNT WITH BRONZE INTERNALS</b>	
8.710-246.0	30Hg - 0 Vacuum Gauge
<b>MOUNTING HARDWARE FOR BACK MOUNT GAUGES</b>	
8.710-223.0	U-Bracket, Mounting
8.710-228.0	3-Hole Flange, Mounting

**PRESSURE GAUGES - STAINLESS-STEEL**



- AISI 304 Stainless-Steel Case
- Bronze Bourdon Tube
- 99.5% Pure Glycerin Filled
- PSI and Bar Dual Scale
- 1/4" NPT Brass Mounting Stem
- Convex Magnifying Lens for Easy Readings
- Steel Needle and Peg
- Accuracy + 1.5%

PART NO.	PRESSURE RANGE	MOUNTING STEM
<b>2-1/2" BOTTOM MOUNT WITH BRONZE INTERNALS</b>		
8.710-270.0	0-100 PSI	1/4" NPT Brass
8.710-272.0	0-200 PSI	1/4" NPT Brass
8.710-273.0	0-300 PSI	1/4" NPT Brass
8.710-276.0	0-500 PSI	1/4" NPT Brass
8.710-278.0	0-1000 PSI	1/4" NPT Brass
8.710-280.0	0-2000 PSI	1/4" NPT Brass
8.710-281.0	0-3000 PSI	1/4" NPT Brass
8.710-283.0	0-4000 PSI	1/4" NPT Brass
9.804-017.0	0-5000 PSI	1/4" NPT Brass
8.710-286.0	0-6000 PSI	1/4" NPT Brass
9.804-001.0	0-10,000 PSI	1/4" NPT Brass
<b>2-1/2" BACK MOUNT WITH BRONZE INTERNALS</b>		
8.710-250.0	0-100 PSI	1/4" NPT Brass
8.710-254.0	0-500 PSI	1/4" NPT Brass
8.710-256.0	0-1000 PSI	1/4" NPT Brass
8.710-257.0	0-2000 PSI	1/4" NPT Brass
8.710-258.0	0-3000 PSI	1/4" NPT Brass
8.710-259.0	0-4000 PSI	1/4" NPT Brass
8.712-149.0	0-5000 PSI	1/4" NPT Brass
8.712-150.0	0-6000 PSI	1/4" NPT Brass
8.710-262.0	0-6000 PSI	1/4" NPT Brass
9.804-013.0	0-10,000 PSI	1/4" NPT Brass
<b>MOUNTING HARDWARE FOR BACK MOUNT GAUGES</b>		
8.710-223.0	U-Bracket, Mounting	1/4" NPT Brass
8.710-228.0	3-Hole Flange, Mounting	1/4" NPT Brass



## PRESSURE GAUGES / TEMPERATURE TEST SET



Convenient test set provides both pressure and temperature check with one easy quick coupled connection at outlet of unloader or coil.



- Test Set 5000  
500°F Thermometer  
5000 PSI Pressure Gauge for  
Systems up to 2000 PSI
- Test Set 10,000  
10,000 PSI Pressure Gauge for  
Systems up to 5000 PSI

PART NO.	DESCRIPTION
8.904-559.0	Test Set 5000 (0-2500 PSI Systems)
8.904-558.0	Test Set 10,000 (0-5000 PSI Systems)

## THROTTLE CONTROL - SPEEDMASTER



Stop overworking the engine and pump during bypass. Decelerator reduces engine speed when pump head pressure drops below 215 PSI, reduces flow during bypass, slows recirculation heat build-up.



- PSI: 3500
- Temperature: 300°F
- A Major System Saver for Gas Engine Units
- Machined-Brass Body
- Stainless-Steel Gland Components
- 1/4" Male Connect
- Viton Seals
- 42" Lined and Covered Control Cable
- Engine Speeds Infinitely Adjustable for "Fine Tuned" System Performance

PART NO.	DESCRIPTION
8.903-840.0	Throttle Control

## VOLTMETERS



- Designated for OEM or Replacement
- Accuracy to + 5%
- Metal Case
- Rugged and Weather-Resistant
- Bright Stainless Bezel
- Utilize as Constant Monitor or as Test Instruments
- Fits 2-1/16" Mounting Hole

PART NO.	DESCRIPTION
8.712-159.0	Voltmeter 120V

## TEMPERATURE GAUGE



Dial thermometers.



- 3" Diameter Dial - Stainless-Steel Case
- Shatter-Resistant Polycarbonate Lens
- Stainless-Steel Stem (2.5")
- 1/2" MPT Connector
- Accuracy to within 3% of Dial Range (50-500+ 6.8°F)

PART NO.	DESCRIPTION
8.712-488.0*	Temp Gauge +50° to 500°F

\*"Thermwell" to be used with dial thermometers in systems over 300 PSI. For best results, fill Thermwell with liquid silicon or glycol to increase sensitivity and accuracy of readings.

## TEMPERATURE GAUGE - THERMWELL

For use with above temperature gauge.



- PSI: 2000 Collapse Protection
- 1.75" Immersion Length
- Stainless-Steel, 3/4" MPT x 1/2" FPT

PART NO.	DESCRIPTION
8.712-489.0	Thermwell for 8.712-488.0

## HOUR METERS FOR GASOLINE ENGINES



- Elapsed Time
- No Battery Required
- Digital Quartz Accuracy (+ .02%)
- Extremely Rugged and Tamperproof
- Sealed from Dirt and Moisture
- Requires 2" Panel Cutout

PART NO.	DESCRIPTION
8.749-183.0	EL 5-80V AC/DC 50/60 Hz
8.749-316.0	EL 24-277 AC/DC 50/60 Hz
9.802-283.0	24-240V AC - Rectangle
8.904-540.0	Tach/Hour 12V DC with Magnet Tool

**BRIGGS & STRATTON ENGINES - GASOLINE**

Briggs & Stratton's top-of-the-line engines have proven performance in the pressure washer industry. They contain the power to complete any job faster and easier with less wear and tear on major engine components.



- Easy, Quick-Starting
- Large Fuel Tank
- Super Quiet Muffler
- OilGaurd® Low-Oil Shutdown
- State-of-the-Art Carburetion System

PART NO.	HP	SHAFT DIA	START	CHARGE RATE	FUEL TANK	MODEL NO.
8.754-819.0	18	1"	Electric	20 Amp	N/A	Vanguard
8.715-067.0	21	1"	Electric	N/A	N/A	Vanguard

Note: Mufflers for the above engine are sold separately. See Briggs & Stratton Engine Parts section below.



OHV Vanguard

- 30% quieter muffler than competition
- Cast / Sintered Iron Sleeve
- OilGaurd® Low-Oil Shutdown

PART NO.	HP	SHAFT DIA	START	CHARGE RATE	FUEL TANK	MODEL NO.
8.709-887.0	11	1"	Recoil	N/A	2 Gal	Vanguard

**BRIGGS & STRATTON ENGINE PARTS**

Genuine Briggs & Stratton replacement parts are available. Please provide engine model / type / code to ensure proper fit of replacement parts. All are authorized manufacturer replacement parts.



8.701-826.0



8.701-823.0

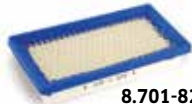

8.701-820.0

PART NO.	DESCRIPTION
8.701-826.0	Briggs 16/18 HP Vanguard, Oil Filter
8.701-820.0	Briggs 5 HP Industrial, Air Filter
8.701-821.0	Briggs 8 or 11 HP IC, Air Filter
8.701-823.0	Briggs 16/18 HP Vanguard, Air Filter
8.718-021.0	Sparkplug, Vanguard, RC12YC

**HONDA ENGINE PARTS**

Original Honda replacement parts from the factory. Filters are a great add-on to every service order. All are authorized manufacturer replacement parts.



8.701-764.0



8.701-830.0



8.701-782.0



8.701-783.0

PART NO.	DESCRIPTION
8.701-830.0	Honda 18/20 HP, Oil Filter
8.701-764.0	Honda GX160, Air Filter
8.701-780.0	Honda GX240/270, Air Filter
8.701-781.0	Honda GX340, Air Filter
8.701-782.0	Honda GX610/620, Air Filter (old style)
8.701-783.0	Honda GX610/620, Air Filter (new style)
8.718-117.0	Honda GX All, Sparkplug

**ENGINES - KOHLER LOMBARDINI - DIESEL**

Kohler Lombardini water cooled diesel engines provide superior power and quiet operation.



- Diesel Powered
- Water Cooled

PART NO.	HP	SHAFT DIA	START	CHARGE RATE	FUEL TANK	MODEL NO.
9.802-327.0	27	1-1/2"	Electric	N/A	No	LDW1003, Water Cooled



## ENGINE PARTS - KOHLER LOMBARDINI

Factory direct Kohler parts. All are authorized manufacturer replacement parts.



8.717-912.0



8.717-915.0

PART NO.	DESCRIPTION	ENGINE MODEL
8.717-912.0	Oil Filter	LDW602/903/1003
8.717-915.0	Air Filter	LDW602/903/10003
8.717-909.0	Fuel Filter	LDW602/903/1003

## STARTER SOLENOID - 12V DC

Universal type used on many lawn and garden tractors and mowers.



- Double Terminal - 5/16", 24 Studs
- Same as used on 16 HP B & S Vanguard Engines
- Rated for Intermittent Duty (i.e. for starting small gasoline engines)

## VOLTAGE REGULATOR - HEAVY-DUTY 15V



- Eliminates need for battery on 12 volt recoil hot water washers

PART NO.	DESCRIPTION
8.701-691.0	12V DC Starter

PART NO.	DESCRIPTION
9.802-531.0	Regulator, Voltage 15 Volts

## KEYED IGNITION SWITCH - 12V DC



- Universal Style / 5 Pole
- Off / On Start (Spring Back to On)
- Panel Nut and Star-Lock Washer
- Two keys included
- Has two auxiliary circuits
- Universal - used for small engine controls on many lawn and garden tractors, mowers

PART NO.	DESCRIPTION
8.701-689.0	Keyed Ignition Switch, 5 Pole
8.701-690.0	Keyed Ignition Switch, 6 Pole

## BALDOR MOTORS - C-FACE OPEN DRIP PROOF (ODP)

Built to "industrial" specifications.



PART NO.	MOTOR HP	RPM	SHAFT DIA	BOLT CIRCLE	FRAME C-FACE	FULL LOAD AMPS	VOLTAGE	MODEL
<b>SINGLE-PHASE MOTORS</b>								
9.107-929.0	2.0	1725	5/8"		56C	16.4/8.2	115/230	EPCL1322M
8.709-754.0	3.0	3450	5/8"	5-7/8"	56C	13.7/12.5	208/230	35K316Y771A4
8.709-723.0	3.0	1725	5/8"	5-7/8"	184CZ	32/16	115/230	36G309-2761
8.709-727.0	4.0	1725	5/8"	5-7/8"	182CZ	17.5/16	208/230	36G551X401G1
8.709-728.0	4.0	3450	5/8"	5-7/8"	56C	38/21/19	115/208/230	35K316S276G1
8.709-730.0	5.0	1725	1-1/8"	7-1/4"	184TC	25/23	208/230	CL1410TM
8.709-731.0*	5.0	3450	5/8"	5-7/8"	56HCY	24/23	208/230	PCL1327M
8.709-733.0	6.0	1725	1-1/8"	7-1/4"	184TCZ	26	230	36G601X288G1
8.709-734.0	7.5	1725	1-1/8"	7-1/4"	215C	36/33	208/230	37N007X177G1

\* SPECIAL MOTOR/ODTF- OPEN DRIP PROOF TANDEM FAN

**BALDOR MOTORS - OPEN DRIP PROOF (ODP)**

Industrial-grade motors built specifically to meet or exceed the demands for the pressure washer industry.



■ The Industry Standard

■ U.L. Listed



**1 Phase, 56 Frame**



**1 Phase, 184T Frame**



**3 Phase, 184T Frame**

PART NO.	MOTOR HP	VOLTAGE	RPM	SHAFT DIA	FRAME	FULL LOAD AMPS	MODEL
<b>SINGLE-PHASE MOTORS</b>							
9.804-516.0	1.5	115V	1725	5/8"	56C	13.6	35R735R770G1
8.754-709.0	<b>S</b> 2.0	115V	1750	5/8"	56C	16.4	35E3197L171G1
8.754-710.0	2.0	115/230V	3470	5/8"	56C	15.6/7.8	35U075L138G1
9.107-929.0	2.0	115/230V	1725	5/8"	56C	16.4/8.2	EPCL1322M
8.715-158.0	2.3	115V	1750	5/8"	56C	18	35Q899R328G1
8.709-751.0	3.0	115/230V	1725	1-1/8"	184T	32/16	L1408TM
8.715-090.0	3.0	208/230V	1725	5/8"	56HC	12.5	35M895T356
8.715-144.0*	5.0	200V	3450	3/4"	56CZ	24.5	35V142R510G1
8.715-146.0	5.0	208/230V	3450	3/4"	56CZ		35L358S214G1
8.709-759.0*	5.0	208/230V	3450	5/8"	56/56H	23/24	PL1327M
8.709-757.0*	5.0	208/230V	1725	1-1/8"	184T	25/23	L1410TM
8.715-091.0	5.0	230V	1725	7/8"	184TCZ	23	36L306W903G1
8.715-142.0	<b>S</b> 5.0	230V	1725	1-1/8"	182TZ	23	36J800X811
9.802-337.0	6.2	200V	1725	1-1/8"	184TZ	30.7	36J468Y852
9.802-336.0**	<b>S</b> 6.2	230V	1725	1-1/8"	184TZ	26	36K907T466
8.715-102.0	<b>S</b> 7.5	230V	1725	1-3/8"	215TZ	31	37H404W885G1
8.715-163.0	8.2	208V	1740	1-3/8"	215T	36.5	37H847Y711G1
8.715-165.0	8.2	230V	1740	1-3/8"	215T	34.5	37H847Y712
8.715-168.0	8.2	230V	3450	1-1/8"	184T	32.8	36E002Y277G1
8.725-973.0	8.2	230V	1740	1-3/8"	215T	34.5	37L276Y712G1
<b>THREE-PHASE MOTORS</b>							
8.751-009.0**	5.0	575V	1750	1-1/8"	184T	5.3	EM3218T-5
8.751-004.0**	6.2	208-230/460	1750	1-1/8"	184T	17.6-17.4/8.7	36G548S590G1
8.751-014.0**	7.5	208-230/460	1770	1-3/8"	213T	20.4-19.4/9.7	EM3311T
8.751-010.0**	7.5	575V	1770	1-3/8"	213T	7.8	EM3311T-5
8.750-999.0**	8.2	208-230/460	1770	1-3/8"	215T	22.2/11.1	37F614S938G1
8.751-005.0**	8.2	575V	3450	1-1/8"	184T	7.4	36G548S515G1
8.751-011.0**	10.0	575V	1770	1-3/8"	215T	10.0	EM3313T-5
8.751-008.0**	20.0	575V	1765	1-5/8"	256T	19.1	EM2515T-5

Note: Amp draw ratings require adequate wire size and full voltage to apply. Full load Amp ratings apply only when full rated.  
 \* SPECIAL MOTOR/ODTF- OPEN DRIP PROOF TANDEM FAN \*\* OPSB = Additional slotted bands to vent the heat.



## MOTORS - TOTALLY ENCLOSED FAN COOLED (TEFC)

Featuring heavy-gauge steel frames, ball bearings, welded base and "snap-action" starting for reliability. Built to industrial specifications.



PART NO.	MOTOR HP	RPM	SHAFT DIA	BOLT CIRCLE	FRAME / C-FACE	FULL LOAD AMPS	VOLTAGE	MODEL
<b>SINGLE-PHASE MOTORS</b>								
8.709-767.0	1.5	1725	5/8"	5-7/8"	56C	12/6	115/230	PCL3514M
8.723-881.0	2.0	1725	5/8"		56C	17.6/8.8	115/230	35W249T988G1
8.709-774.0	2.0	3450	5/8"	5-7/8"	56C	17.6/8.8	115/230	PCL3515M
8.709-779.0	3.0	3450	5/8"	5-7/8"	56C	13.7/12.5	208/230	PCL3519M
8.709-784.0	5.0	1725	1-1/8"	7-1/4"	184TC	23	230	CL3612TM
8.709-737.0	7.5	1725	1-1/8"	7-1/4"	215C	34.1/30.8	208/230	37H209T032
8.709-793.0	10.0	1740	1-3/8"		215T	38	230	L3712T
<b>THREE-PHASE MOTORS</b>								
8.751-318.0	5.0	1750	1-1/8"	7-1/4"	184TC	13.9-13.4/6.7	208-230/460	CEM3615T
8.751-016.0	10.0	1770	1-3/8"		215T	25.4-24/12	208-230/460	EM3714T

## MOTORS - A.O. SMITH - PRESSURE WASHER - OPEN DRIP PROOF (ODP)

Excellent power efficiency.



PART NO.	MOTOR HP	RPM	SHAFT DIA	BOLT CIRCLE	FRAME / C-FACE	FULL LOAD AMPS	VOLTAGE	MODEL
<b>SINGLE-PHASE MOTORS</b>								
8.709-808.0	6.0	3600	7/8"	5-7/8"	56Y	22.0	208/230	B869

## REFERENCE / CALCULATION GUIDE

Conversion Factors	Horsepower (HP) Equations	QUESTIONS AND ANSWERS
1 inch = 25.4 mm	HP = $\frac{\text{GPM} \times \text{PSI}}{1460}$	How fast do I turn my pump to give me a desired GPM?
1 cm = 0.394 inch	PSI = $\frac{\text{HP} \times 1460}{\text{GPM}}$	Required RPM = $\frac{(\text{Desired GPM} \times \text{Rate RPM})}{\text{Rated GPM}}$
1 gal H2O = 8.33 lbs.	GPM = $\frac{\text{HP} \times 1460}{\text{PSI}}$	How fast do I turn my pump to give me a desired GPM?
1 oz. = 23.35 gram		Pump Pulley Diameter = $\frac{\text{Motor Pulley Diameter} \times \text{Motor RPM}}{\text{Pump RPM}}$
1 gal = 3.79 liter		
1 liter = 0.2642 gal		



**MOTORS - WEG - PRESSURE WASHER - OPEN DRIP PROOF (ODP)**

Built to industrial specifications.



- Three-Phase Motors
- 1800 RPM
- Rolled Steel Platform



PART NO.	MOTOR HP	SHAFT DIA	FRAME	FULL LOAD AMPS	VOLTAGE	MODEL
8.755-598.0	5.0	1-1/8"	182/4T	14.6	200	005180T3P184T-S
8.755-599.0	10.0	1-3/8"	213/5T	28.5	200	010180T3P215T-S
8.755-600.0	15.0	1-5/8"	254/6T	42.2	200	015180T3P254T-S
8.755-601.0	20.0	1-5/8"	254/6T	56.8	200	020180T3P256T-S
8.755-606.0	7.5	1-3/8"	213/5T	21.0	200	007180T3P213T-S
8.756-431.0	20.0	1-5/8"	254/6T	55.3-50.0/25.0	208-230/460	020180T3E256T-S
8.755-604.0	7.5	1-3/8"	213/5T	20.5-18.5/9.25	190/380/208-230/460	007180T3E213T-S
8.755-605.0	10.0	1-3/8"	213/5T	27.4-24.8/12.4	190/380/208-230/460	010180T3E215T-S
8.756-425.0	5.0	1-1/8"	182/4T	14.0-12.7/6.33	190/380/208-230/460	005180T3E184T-S
8.756-429.0	15.0	1-5/8"	254/6T	41.1-37.2/18.6	190/380/208-230/460	015180T3E254T-S

**SMALL ENGINE TEST EQUIPMENT**



**SPARK TESTER**

- Connects between plug and plug wire
- Totally Contained Spark
- Engine will run with tester attached
- Neon test light verifies proper ignition
- Handy tool allow safe, easy visual inspection of ignition output



**COMPRESSION TESTER**

- Designed for small engines
- 2-1/2" dial reads up to 300 PSI
- 12" flexible hose to reach spark plug holes
- Adapters for 14 mm and 18 mm spark plug holes
- Built-in pressure holding / release valves



**WIRELESS TACHOMETER**

- Terrific service aid for 1-cylinder engines
- Just hold built-in antenna near spark plug
- Two scales: 0-5,000 RPM or 0-15,000 RPM
- Solid-State Electronics
- Requires 9V Battery (not included)
- Excellent for setting GPM on pressure washers; accuracy within 2% of full scale

PART NO.	DESCRIPTION
8.701-680.0	Spark Tester
8.701-682.0	Compression Tester
8.701-681.0	Wireless Tach

## COUPLERS SECTIONS - BROWNING / LOVEJOY

Listed as individual coupler sections (half) to allow flexibility in design. For complete coupler select: Bore size for motor + Bore size for pump + Spider = Complete Coupler.

Please Note: Select halves from same series as listed in groups below. (e.g. All "090/095", "099/100")



PART NO.	DESCRIPTION	BORE
<b>090/095 SERIES: UP TO 3 HP ELECTRIC OR 4 HP GAS</b>		
8.709-620.0	Coupler Half	24 mm
8.709-640.0	Coupler Half	5/8" (090)
8.709-634.0	Coupler Half	3/4" (090)
8.709-639.0	Buna Spider for 090 (STD)	
<b>099/100 SERIES: UP TO 5-7 1/2 HP ELECTRIC OR 5-13 HP GAS</b>		
8.709-626.0	Coupler Half	3/4" (100)
8.709-625.0	Coupler Half	20 mm (100)
8.709-627.0	Coupler Half	24 mm (099)
8.709-628.0	Coupler Half	24 mm (100)
8.709-629.0	Coupler Half	1" (100)
8.709-632.0	Coupler Half	1-1/8" (100)
8.709-637.0	Coupler Half	1-3/8" (100)
8.709-633.0	Buna Spider for 099/100 (STD)	

## PULLEY BUSHINGS

Split taper "H"



- Split Taper, Malleable Iron
- Keyed to Both Shaft and Hub
- Highest Torque Carrying Capacity

PART NO.	SIZE
<b>MOTOR / ENGINE BUSHINGS</b>	
9.802-397.0	H X 5/8"
9.803-897.0	H X 3/4"
8.715-633.0	H X 7/8"
9.802-399.0	H X 1"
9.802-400.0	H X 1-1/8"
9.802-401.0	H X 1-3/8"
8.715-638.0	H X 1-3/8" - 6B, Spline
<b>PUMP BUSHINGS</b>	
8.711-118.0	H X 20 mm
8.711-119.0	H X 22 mm
9.802-402.0	H X 24 mm
9.802-403.0	H X 25 mm
8.715-646.0	H X 30 mm
8.711-124.0	H X 32 mm
8.711-125.0	H X 35 mm

## PULLEYS

Fits Interpump, General and Admiral XLS, XDS Series pumps, plus XD3040, XD3047, XD3047, XD3055 and XD3065.





- Double Groove
- 24 mm Bore
- 2 x A Groove

PART NO.	OD
8.711-115.0	4.0"
8.711-116.0	5.5"
8.711-117.0	6.3"

## V-BELTS - SUPER "GRIPNOTCH"



- Full Line of Belts
- "V"-notched for longer life and better performance

PART NO.	SIZE
8.715-669.0	AX26
8.715-671.0	AX28
8.715-672.0	AX29
8.715-673.0	AX30
9.804-026.0	AX31
9.803-896.0	AX33
9.802-407.0	AX34
9.803-683.0	AX35
9.802-408.0	AX36
9.802-409.0	AX37
9.802-410.0	AX38
8.715-682.0	AX41
9.802-411.0	AX42
9.802-412.0	 BX22
9.802-413.0	BX32
9.802-414.0	BX34
9.802-415.0	BX35
9.802-416.0	 BX36
8.715-698.0	BX37
8.710-745.0	BX38
9.802-418.0	BX39
8.715-701.0	 BX40
8.715-702.0	BX41
9.802-419.0	BX42
9.802-420.0	BX43
9.802-421.0	BX44
8.710-756.0	BX45
8.715-706.0	BX46
8.715-708.0	BX48
8.715-710.0	BX51

**PULLEYS**

High-quality, cast-iron pulleys, Cast design. All sizes available.



**AK Pulley**



**2AK Pulley**



**BK Pulley**



**2BK Pulley**



**3TB Pulley**

PART NO.	SIZE	OD
8.715-517.0	AK21*	2.10"
8.715-519.0	AK23*	2.30"
9.802-368.0	AK25*	2.50"
9.804-028.0	AK28*	2.80"
8.715-527.0	AK32H	3.25"
8.715-530.0	AK34H	3.45"
9.803-898.0	AK39H	3.75"
9.802-369.0	AK74H	7.25"
8.715-538.0	AK84H	8.25"
8.715-539.0	AK89H	8.75"
9.803-298.0	2AK30H	3.05"
9.802-371.0	2AK32H	3.25"
9.804-047.0	2AK34H	3.45"
8.715-546.0	2AK44H	4.25"
8.715-548.0	2AK49H	4.75"
8.715-549.0	2AK51H	4.95"
9.802-372.0	2AK54H	5.25"
8.715-555.0	2AK94H	6.25"
9.802-374.0	2AK74H	7.25"
9.802-375.0	2AK84H	8.25"
9.803-548.0	2AK94H	9.25"
8.715-560.0	BK30H	3.30"
9.802-377.0	BK32H	3.35"
9.802-379.0	BK36H	3.75"
8.715-566.0	BK40H	3.95"
8.710-819.0	BK45H	4.25"
8.710-823.0	BK47K	4.45"
8.710-831.0	BK52H	4.95"

PART NO.	SIZE	OD
8.710-837.0	BK60H	5.75"
8.715-568.0	BK65H	6.25"
8.715-570.0	BK70H	6.75"
8.715-571.0	BK75H	7.25"
9.802-380.0	BK80H	7.75"
8.715-573.0	BK85H	8.25"
8.710-858.0	BK100H	9.75"
8.715-576.0	2BK32H	3.35"
9.802-382.0	2BK34H	3.55"
9.802-383.0	2BK36H	3.76"
9.802-384.0	2BK40H	3.95"
9.802-385.0	2BK45H	4.25"
8.715-582.0	2BK47H	4.45"
8.715-583.0	2BK50H	4.75"
9.802-386.0	2BK52H	4.95"
9.802-387.0	2BK60H	5.75"
8.715-588.0	2BK62H	5.95"
9.804-060.0	2BK65H	6.25"
9.802-388.0	2BK67H	6.45"
8.715-591.0	2BK70H	6.75"
9.802-389.0	2BK80H	7.75"
8.715-593.0	2BK90H	8.75"
9.802-391.0	2BK100H	9.75"
8.715-598.0	2TB40	4.35"
9.802-392.0	3TB34	3.75"
9.802-394.0	3TB40	4.35"

\* X 5/8" BORE

## BURNERS - BECKETT - 115V / 230V

Ergonomically designed to be the most comfortable gun on the market.



- .4 to 3 GPH firing rate
- 6-1/4" Blower Fan, 115V and 230V
- 3,450 RPM Pump / Blower Motor
- Solid-State Ignition
- Beckett "CleanCut" Fuel Pump with Oil Valve
- Air Tube: 2-3/4"
- UL-Recognized

PART NO.	DESCRIPTON
8.709-325.0	Beckett AFG 115
8.709-326.0	Beckett AFG 230

## BURNER CHART - BECKETT



BURNER			MOTOR		BLOWER WHEEL		IGNITOR ASSEMBLY	
PART NO.	DESCRIPTON	BECKET NO.	PART NO.	BECKET NO.	PART NO.	BECKET NO.	PART NO.	BECKET NO.
8.709-326.0	AFG, 240V 3"	VMG202	8.750-518.0	22825U	9.802-649.0	2999U	8.751-780.0	5199701U
8.709-325.0	AFG, 120V AC	VMG902	9.802-642.0	21805U	9.802-649.0	2999U	9.802-647.0	51771U
8.709-327.0	ADC, 13.5V DC - without ICB*	VMG504	9.802-638.0	52145U	9.802-636.0	2999AU	8.751-784.0	5218301U
8.709-328.0	ADC, 13.5V DC - with ICB*	VMG505	9.802-638.0	52145U	9.802-636.0	2999AU	8.751-784.0	5218301U
8.717-071.0	SM, 120V	HO1501	8.701-090.0	2364U	9.803-057.0	2383U	9.803-060.0	51824U
8.717-090.0	SM, 240V	HO1301	8.701-093.0	21344U	9.803-057.0	2383U	8.751.781.0	5199702U

\*Ignition Control Board

BURNER			FUEL PUMP		SOLENOID WITH CORD SET		TUNE UP KIT	
PART NO.	DESCRIPTON	BECKET NO.	PART NO.	BECKET NO.	PART NO.	BECKET NO.	PART NO.	BECKET NO.
8.709-326.0	AFG, 240V AC	VMG202	9.802-644.0	2184403U	8.900-082.0	N/A	8.723-715.0	578730
8.709-325.0	AFG, 120V AC	VMG902	9.802-645.0	2184405U	8.900-081.0	N/A	8.723-715.0	578730
8.709-327.0	ADC, 13.5V DC - without ICB*	VMG504	9.802-562.0	2184402U	8.900-080.0	N/A	8.723-715.0	578730
8.709-328.0	ADC, 13.5V DC - with ICB*	VMG505	9.802-562.0	2184402U	8.900-080.0	N/A	8.723-715.0	578730
8.717-071.0	SM, 120V	HO1501	9.802-645.0	2184405U	8.900-081.0	N/A	8.723-715.0	578730
8.717-090.0	SM, 240V	HO1301	9.802-644.0	2184403U	8.900-082.0	N/A	8.723-715.0	578730

\*Ignition Control Board

## BURNERS - BECKETT 14V DC



- 14V, Solid-State Ignition
- 1/6 HP
- 3,450 RPM
- 4-1/4" Fan
- Max Rate 2.5 GPH
- Beckett "CleanCut" Fuel Pump with Oil Valve

PART NO.	DESCRIPTION	OIL VALVE	ELECTRIC EYE	MOTOR RPM
8.709-327.0	Beckett, 13.5V, VMG504	Yes	-	3450
8.709-328.0	Beckett, 13.5V, VMG505	Yes	Yes	3450

Note: Proper operation requires an engine with 16+ Amp alternator and deep-cycle battery on nightly, overnight recharge

Specifications, product descriptions, product availability, and pricing subject to change without notice.

**FLEX COUPLINGS - BECKETT**



PART NO.	BECKETT NO.	DESCRIPTION
9.802-648.0	2454	A/AF/AFG/NX
9.803-058.0	2433	5/16" X 1/2" SR/SF/SM/CF
9.802-637.0	2140501U	12V DC ADC

**BURNER PARTS - BECKETT - MISC REPAIR**



PART NO.	BECKETT NO.	DESCRIPTION
9.802-651.0	31332	Mntg Flange Gasket, 323005
8.701-059.0	578726	Electrode Insltr Assy,- SDC
8.701-063.0	5432	Flange, Adj, with Gasket (All)
8.723-912.0	5850	Flange, Split, Adj, with Gasket
8.701-070.0	31653	Gasket, Universal Flange (Replaces 3616)
9.802-653.0	31802	Gasket, Mtg Flange, 4 slot Square (Replaces 3416)
8.701-085.0	5717 (51400)	Knurled Nut Kit ADC
8.701-134.0	51304	Gasket Kit, Xfmr Mntg -A/AF/AFG/NX
8.701-132.0	31404	Clamp, Xfmr Mntg Plate
9.802-676.0	7006U	Cad Cell Eye with leads-A/AF/AFG/NX/SR/SF
8.701-137.0	7556A0000U (7556A)	Burner Control, 12V DC
8.701-133.0	3245	Spring, Xfmr Contact
8.701-106.0	AF90	9" Air Tube Assy without Head, Includes 51400
8.701-074.0	5151501	Air Band, 8 Slot- A/AF/AFG

**BURNER PARTS - BECKETT - ELECTRODE / INSULATOR ASSEMBLY**



PART NO.	BECKETT NO.	DESCRIPTION
9.802-668.0	5780	Electrode Insulator Kit: AF/AFG/AR/SF/SR
8.717-978.0	578728	Electrode Insulator Assembly EA17305H-ADC
9.802-669.0	578711	Electrode Insulator Assembly EA13602J withContact
9.802-670.0	578727	Electrode Insulator Assembly EA15602J
8.751-342.0		Electrode Ignition AC/DC

**BURNER CONTROLLER AND CONTRACTOR TOOL - GENISYS™**

Advanced burner control, 120V AC primary safety control for residential and light commercial oil burners.



PART NO.	BECKETT NO.	DESCRIPTION
8.751-335.0	7505A	Genisys Controller
8.726-018.0	52082U	Genisys Contractor Tool

**BURNERS - WAYNE**



**115V AND 220V WAYNE BURNER**

- 75 to 3 GPH Firing Rates
- Solid-State Ignition (Low Amp)
- 3,450 RPM Pump / Blower Motor
- "A"-Type Suntec Fuel Pump
- UL-Recognized
- High-volume 6-1/4" blower on 220V unit, 5-3/16" blower on 110V unit
- 3-3/4" air tube with adjustable flange for maximum versatility



**12V WAYNE BURNER CHART**

- 12V Solid-State Ignitor
- 3,450 RPM Fuel Pump
- .5 to 2.75 GPH Capacity with Oil Valve

PART NO.	DESCRIPTION
8.709-317.0	115V AC Burner with Oil Valve - EHASR
8.709-318.0	230V AC Burner with Oil Valve - EHASR
8.709-319.0*	 12V DC Burner with Oil Valve - MSRDC

\*Proper operation requires an engine with 16+ Amp alternator and deep-cycle battery on nightly, overnight recharge

**BURNER CHART - WAYNE**



PART NO.	DESCRIPTION	IGNITOR	TRANSFORMER	MOTOR
8.709-317.0	Wayne 115V	8.700-802.0 079111	8.700-804.0 079115	8.701-095.0 079612
8.709-318.0	Wayne 220V	N/A N/A	8.700-809.0 079123	8.701-094.0 079611
8.709-319.0	Wayne 12V	8.700-807.0 079120 Includes	N/A N/A	8.700-739.0-FASCO 079021  8.750-715.0-MET to FASCO 079021X

Note: 8.700-721.0 - Coupling for 8.700-740.0 FASCO motor used on MET to FASCO converted burner  
 8.700-720.0 - Adapter Bushing to allow MET blower wheel to work with FASCO motor  
 8.700-740.0 - Conversion Kit, use MET to FASCO conversion kit if 12V burner motor cannot be identified.  
 The kit contains the following parts: 8.700-739.0 Motor, 8.700-720.0 Adapter Bushing, 8.700-682.0 Adapter Plate, 8.700-721.0, Coupling, 8.700-691.0 Screws (2), 8.700-104.0 Nuts

PART NO.	DESCRIPTION	BLOWER WHEEL	FUEL PUMP	SOLENOID VALVE	ELECTRODE ASSEMBLY
8.709-317.0	Wayne 115V	8.700-730.0 079005	8.700-749.0 079030	8.700-779.0 079062	8.700-770.0 079052
8.709-318.0	Wayne 220V	8.700-731.0 079006	8.700-749.0 079030	8.700-780.0 079063	8.700-770.0 079052
8.709-319.0	Wayne 12V	8.700-727.0-FASCO 079003  2.44"W x 2.53" T 5/16" Shaft 8.700-728.0 (079003A) MET 3.44" W x 4.25" T 1/2" Shaft	8.700-749.0 079030	8.700-782.0 079064	8.700-774.0 079056 with 8.700-721.0 coupling for converting from MET to FASCO

Note: 8.700-721.0 - Coupling for 8.700-740.0 FASCO motor used on MET to FASCO converted burner  
 8.700-720.0 - Adapter Bushing to allow MET blower wheel to work with FASCO motor  
 8.700-740.0 - Conversion Kit, use MET to FASCO conversion kit if 12V burner motor cannot be identified.  
 The kit contains the following parts: 8.700-739.0 Motor, 8.700-720.0 Adapter Bushing, 8.700-682.0 Adapter Plate, 8.700-721.0, Coupling, 8.700-691.0 Screws (2), 8.700-104.0 Nuts



**BLOWER WHEELS - WAYNE**



PART NO.	WAYNE NO.	DESCRIPTION	SHAFT SIZE
8.700-730.0	20288 / SER	5-3/16" X 3-7/16"	1/2"
8.700-731.0	21854 / SER	6-14" X 4-3/16"	1/2"
8.700-726.0	20673	4-1/4" X 3-1/8"	1/2"
8.700-727.0	21427 / SER3	12V (FASCO)	5/16"
8.700-728.0	21427	(MET)	1/2"

**BURNER REPAIR PARTS / COMMON - BECKETT & WAYNE**



Brass Elbow

Oil Line



PART NO.	DESCRIPTION
8.701-054.0	Oil Line, 6.5", Copper
9.802-667.0	Oil Line, 8", Copper
8.701-053.0	Oil Line, 9.5", Copper
8.700-784.0	Brass 90° Elbow 1/8" Flare, 1/8" MPT
8.700-785.0	Brass 90° Elbow 3/16" Flare, 1/8" MPT
8.700-738.0	Oil Pressure Gauge 0-200 PSI
8.700-768.0	(28737-1) Nozzle Adapter
8.705-063.0	Straight Thru Double Nipple 1/8" x 1/8"

**BURNER REPAIR PARTS - WAYNE**



PART NO.	WAYNE NO.	DESCRIPTION
8.700-774.0	31156	Wayne Burner Tune-up Kit
8.700-770.0	14733-001	Electrode Assembly (Pair)
8.700-743.0	12945	Buss Bar - G Shape
8.700-754.0	14344	Burner Gasket- 4" (E-Series)
8.700-692.0	12484	Universal Flange Gasket- 7 3/8" x 4 5/16"
8.700-735.0	20372	Burner Housing (E-Series)
8.700-736.0	2689-SER	Adj. Flange Kit with Gasket-Serv
8.700-776.0	13279	Shaft Coupler - 5/16"(Green) x 1/2" (Gray) - 4.33" long
8.700-777.0		Coupler End (J Pump 7/16")
8.700-733.0	13360	Transformer Clip Screw, 5/16"-15
8.700-734.0	13038	Transformer Hold Down Clip
8.700-729.0	2668-002	Outer Air Band (8 Hole)
8.700-732.0	2669-002	Inner Air Band (8 Hole)
8.700-714.0	31702-014	Gun Assy, F/307007
8.700-680.0	21913-SER	Nzl Adaper with Legs MSR / DC

## BURNER MOTORS

	PART NO.	CAPACITOR	RPM	HP	FLANGE	VOLTAGE	WAYNE / BECKETT	
 48M 5.75" Diameter	9.802-642.0	Y	3450	1/7	48M	115V	20627 / 21805U	
	8.750-518.0	Y	2850 / 3450	1/7	48M	220V	NA / Beckett PN#22825U	
	8.700-739.0		4500	1/5	48M	12V DC	21993-005 / N/A	
	9.802-638.0	Kit	3450	1/6	48M	13.5V	N/A / 52145U	
	8.701-090.0		3450	1/4	48N	115V	N/A / 2364U	
	8.701-091.0		3450	1/4	48N	12V	N/A / 52146U	
 48N 7.25" Diameter	8.701-093.0	Y	3450	1/4	48N	115/240V	N/A / 21344	
	8.701-094.0		3450	1/5	48N	240V	21328 / 21173U	
	8.701-095.0		3450	1/5	48N	115V	20554 / 2900U	
	8.700-740.0	Kit, 12V DC / MET to FASCO						
	<b>UNIVERSAL</b>							
	8.700-741.0			3450	1/7	48M	110-60 Hz	
	8.700-744.0			3450	1/5	48N	110/240V	Capacitor Start

## BURNER TUNE UP KIT - BECKETT

Fits all Beckett Burners with 3" or 3-5/8" air tube.



### KIT CONTAINS:

- Four Beckett Electrodes
- Two Couplings
- One Fuel Line
- T-Gauge

PART NO.	DESCRIPTION
8.723-715.0	Beckett Burner Tune-up Kit

## BLOWER WHEELS - BECKETT



PART NO.	DESCRIPTION	SHAFT SIZE
9.803-057.0	6-1/4" D x 3-7/16" W	1/2", SR/SF/SM
9.802-649.0	4-1/4" D x 2-1/2" W	1/2", AFG/ADC
9.802-636.0	4-1/4" D x 2-7/16" W	1/2" & 5/16", AFG/ADC

## FUEL CONDITIONER AND SOOT REMOVER

Red Devil eliminates soot build-up.



- Easy to Use - just add to burner fuel
- Keeps burner at top efficiency
- 1 oz. Per 10 Gallons

PART NO.	DESCRIPTION
8.704-625.0	Pint (16 oz.)
8.704-626.0	Quart

## FUEL PUMP - BECKETT CLEAN CUT

Simple design provides faster cleaning, more reliable cut-offs, and cut-ons. Cleaner operation - less soot. More reliable - fewer moving parts. Reduced motor load in start-up. Higher capacity - 4 GPH at 100 PSI.



- PSI: 100-200
- Factory Set PSI: 100
- Inlet Pressure PSI: 10
- Rated Speed: 3,600 RPM
- Includes built-in solenoid with cord set

PART NO.	DESCRIPTION
9.802-645.0	110V
9.802-644.0	220V
9.802-562.0	12V
9.802-646.0	Valve Stem Kit (21877U)

## BURNER IGNITORS - BECKETT



- Solid-State Technology
- 14,000V Spark
- Only .35 AMP @ 110V
- 1.7 lbs.

PART NO.	BECKETT PART NO	NO MOUNTING	VOLT
9.802-647.0	51771U	AFG/Lo Amp	120V
8.751-788.0	5218309U	ADC/ SDC	12V DC
8.751-785.0	517780	SDC w/Con BD	12V DC
9.803-060.0	51824U	SM/SF	120V
8.701-140.0	51779U	SDC w/o CB	12V DC

\*Complete with timer

**FUEL PUMPS & REPLACEMENT PARTS - SUNTEC**



■ Use with Single- or Dual-Line Systems

■ Pressure Adjustment Valve



PART NO.	SUNTEC NO.	GPH	RPM	ROTATION
<b>STANDARD PUMPS</b>				
8.700-749.0	<b>S</b> A2VA7116	3.0	3450	RH
8.700-789.0	A2VD-7119	3.0	3450	LH
8.700-756.0	A1YA7912	7.0	1725	RH
8.700-757.0	A2YA7916	7.0	3450	RH
8.700-748.0	A2RA7710	2.5		RH
<b>PUMPS WITH SOLENOID</b>				
8.754-705.0	OL35, 12/24V			
8.754-706.0	<b>S</b> OL35, 120V	3.0		
8.754-707.0	OL35, 230V			
8.700-758.0	<b>S</b> A2VA3106-N221R/ 12-24V	4.0	3450	RH
8.700-760.0	<b>S</b> A2VA-3106-N721R / 230V	3.0	3450	RH
<b>PUMP REPLACEMENT PARTS</b>				
8.700-764.0	3715732 (A2VA 7116)	Pump Fuel Screen		
8.717-878.0	3715744 (A2AVA 7916)	Screen with Gasket		
8.700-765.0	3779801 Gasket Cover	Gasket Cover		

**BURNER TRANSFORMERS - BECKETT**



■ 10,000V Spark  
 ■ 2.2 AMP @ 120V

■ 8.5 lbs.  
 ■ Traditional Copper-Wire Wound



PART NO.	BECKETT NO.	MOUNTING	VOLT
8.751-780.0*	5250001U	AF/AFG/NX/CF375	240V
9.803-060.0*	51824U	A-SF-SR-SM	120V
8.751-781.0*	5250002U	SM/SF/CF500/CF800	240V

\*Bottom Mount

**BURNER TRANSFORMERS - ALLANSON**



■ 10,000V Spark  
 ■ 2.2 AMP @ 120V

■ 8.5 lbs.  
 ■ FranceFormer



PART NO.	ALLANSON NO.	WAYNE NO.	MOUNTING	VOLT
8.700-804.0	<b>S</b> 2721-620	23101/E	Side / EH-EHA	120V
8.700-806.0	2721-628G	23101/M	Back / M-MSR	120V
8.700-809.0	2744-620	23103/E	Side / EH-EH	230V
8.700-798.0	2729-619	23103/M	Back	220V

## BURNER IGNITOR / BASE PLATES - BECKETT



PART NO.	BECKETT NO.	DESCRIPTION
8.701-116.0	51830U	A, Trans / Ign
8.701-117.0	51831U	S, Trans / Ign
8.701-118.0	51833U	E, Trans / Ign
8.701-119.0	51829U	M, Trans / Ign

## FUEL NOZZLE TRAY



PART NO.	DESCRIPTION
8.700-849.0	Nozzle Tray (Metal) Open Top, 55-Compartment, Plastic

## BURNER IGNITORS - WAYNE



- Solid-State Technology
- 14,000V Spark

- Only .35 AMP @ 120V
- 1.7 lbs.



PART NO.	WAYNE NO.	MOUNTING	VOLT
8.700-810.0	23101-FH	Side, FH-FHA	120V
8.700-802.0	101295-SERE	Side, EH/EHA/EHASR	120V
8.700-803.0	101295-SERM	Back, M/MH/MSR	120V
8.700-801.0	31812-002	Back, M-MSR	220V
8.700-807.0	31812-003	Bottom, W/M	12V
8.700-820.0	31813-003	Side Mount (E)	12V

## BURNER IGNITORS - ALLANSON



PART NO.	ALLANSON NO.	WAYNE NO.	MOUNTING	VOLT
8.700-800.0	2280-620S	31813-002	Side, E/EH/EHA/EHS	220V

## FUEL SOLENOID VALVE - 12V DC KIP



- Brass Body
- 12V DC Coil
- 1/8" NC, FPT, I/O Ports
- Conduit Connector
- 5/64" Orifice = 6 Watt

PART NO.	DESCRIPTION
8.701-120.0	Fuel Solenoid Valve

## SMOKE TESTER - DIAGNOSTIC TOOL

A Properly Tuned Burner:



- Heats water more efficiently
- Doesn't build up soot in the coil
- Doesn't pollute the air
- Keeps your customers happy
- A tool that should be used by every serviceman in the industry

PART NO.	DESCRIPTION
8.712-507.0	Smoke Tester
8.712-506.0	Filter Paper Refill*

\*40 sheet (10 tests per sheet)

**FUEL SOLENOID VALVES / COILS - SUNTEC**



- PSI: 300
- 1/8" FPT Inlet
- Unitized mounting on Suntec fuel pumps
- Uses Standard Suntec Coil

PART NO.	DESCRIPTION
8.700-779.0	110V Oil Valve, Non-Delay, R642NL
8.700-780.0	220V Oil Valve, Non-Delay, R753NL
8.700-782.0	12 Oil Valve, Non-Delay, R261NL
8.900-081.0	110V Coil with Cord Set
8.900-082.0	230V Coil with Cord Set
8.900-080.0	12/24 Coil with Cord Set
9.802-640.0	115V Coil without Cord Set
9.802-641.0	230V Coil without Cord Set
8.700-794.0	12/24V DC Coil without Cord Set
8.700-795.0	Cord Set Only
8.900-079.0	8mm Nut for Old Style Coil

**GAS JETS**



PART NO.	DRILL SIZE	ORIFICE SIZE	USE
<b>GAS JETS FOR BURNER RINGS</b>			
8.710-215.0	#52	(.0635)	NG
8.710-216.0	<b>S</b> #54	(.055)	NG
8.710-217.0	#62	(.038)	LP
8.717-377.0	#63	(.037)	LP
8.710-218.0	#65	(.035)	LP
8.710-219.0	#66	(.033)	LP
9.802-684.0	#69	(.029)	LP
8.710-214.0	Blank (Must Be Drilled)		

**GAS VALVES - HONEYWELL**



9.803-615.0      9.803-616.0      8.718-048.0      9.803-612.0      9.803-613.0      9.803-610.0

PART NO.	DESCRIPTION
<b>NATURAL GAS - SMALL MILLIVOLT VALVE</b>	
9.803-615.0	Natural Gas Millivolt Valve, 3/4" NPT
9.803-617.0	NG Pilot for Piezo Ignitor
9.803-611.0	Thermopile/Powerpile with Spade Terminals, 47"
9.803-614.0	LP Conversion Kit (NG to LP)
8.718-116.0	NG Conversion Kit (LP to NG)
<b>NATURAL GAS - SMALL ELECTRONIC IGNITION VALVE</b>	
9.803-616.0	Natural Gas Electronic Ignition Valve, 24V, 3/4" NPT
9.803-618.0	LP Conversion Kit (NG to LP)
8.718-112.0	NG Conversion Kit (LP to NG)

PART NO.	DESCRIPTION
<b>NATURAL GAS / LP - LARGE ELECTRONIC IGNITION VALVE</b>	
8.718-050.0	NG Diaphragm Gas Valve, Single Stage Pressure Regulating, Slow Opening (No LP Conversion Kit)
8.718-048.0	LP Diaphragm Gas Valve, Single Stage Pressure Regulating, Slow Opening. (No NG Conversion Kit)
9.803-612.0	Pilot Gas Solenoid Valve, 24V, 1/4" Small Normally Closed
<b>ELECTRONIC IGNITION</b>	
9.803-613.0	Electronic Ignition Controller Back 90 sec TFI
9.803-610.0	Pilot, Electronic Ignition
9.803-562.0	48" Ignition Cable
8.905-681.0	60" Ignition Cable
8.930-332.0	69" Ignition Cable



## GAS REGULATORS - NATURAL GAS

■ A.G.A. Design Certified

■ CGA Certified



PART NO.	SIZE	VOLTAGE	MODEL NO.	BRAND
9.803-616.0	3/4"	24V	VR8304M4002B	Honeywell
8.710-182.0	3/4"	120V	36C03A-410	White Rogers
8.717-766.0	3/4"	Millivolt	VS820A1088/U	Honeywell
8.718-099.0	3/4"	24V	SV9601M4167/B	Honeywell
8.710-174.0	1"	24V	700-059	Robert Shaw with Pilot
9.802-674.0	1"	24V	7000 DERHC, 5N2-501-531	Robert Shaw

## GAS REGULATORS - LP GAS CONVERSION KITS

■ A.G.A. Design Certified

■ CGA Certified

PART NO.	MODEL NO.	DESCRIPTION
8.718-111.0	F0092 073700S1 (F92-0737)	Fits White Rogers: 36C Series
9.803-614.0	391937/U	Fits: V/VR800 Series, Standard & Delay Models
9.803-618.0	393691/U	Fits Honeywell: VR/SV Series
8.710-187.0	1751-013	Fits Robert Shaw: 7000, 7010, 7100, 7200 and 7222

## GAS REGULATORS - LP



8.717-746.0



9.802-633.0

■ High Quality Fischer Regulators

■ High and Low Pressure

PART NO.	MODEL NO.	DESCRIPTION
8.717-752.0	LV404B96	LP,F.POL X 3/4" F.NPT, 525K BTU
8.717-746.0	R122HAAJ	1st Stage,High Pressure,1,180,000 BTU
8.717-747.0	R622CFF	2nd Stage, Low Pressure- Reducing
8.717-749.0	R632CFF	Integral 2 Stage, 1/4" x 3/4" NPT
9.802-633.0		LP Assembly, Includes High / Low Pressure Assy

## PROPANE GAS HOSE



PART NO.	DESCRIPTION
8.711-853.0	LP 1/4" x 10' POL x POL
8.711-856.0	LP 1/2" x 48", MNPT Both Ends
8.711-854.0	LP 1/4" x 18" MPOL Both Ends
8.711-864.0	LP 3/4" x 16" MNPT Both Ends

## PROPANE TANKS

PART NO.	DESCRIPTION
8.717-791.0	Tank, 43#, without OPD Valve

Note: No Air Freight Shipments



**DRAFT DIVERTERS & RAIN CAPS**



- Prevents backdrafts and keeps cold air out
- Fits on Standard Stove Pipe
- Hot Dipped Galvanized
- Prevents water from running down vent pipes

PART NO.	DESCRIPTION
8.717-764.0	8" Oil Fired, Barometric Dampener
8.717-728.0	8", Round Gas-Fired
9.801-040.0	10", Round Gas-Fired
8.717-730.0	12", Round Gas-Fired
<b>RAIN CAPS</b>	
9.105-845.0	8", Exhaust Stack, Cap
8.717-731.0	10", Exhaust Stack, Cap
8.717-732.0	12", Exhaust Stack, Cap

**GAS PILOTS**



PART NO.	DESCRIPTION
8.718-100.0	LP Orifice HS, Q3480C 1437 (829858)
8.718-101.0	NG Orifice HS Q3480C 1205 (829977)
8.718-011.0	NG Pilot Burner & Ignition with Orifice (Q345A1073/B)
9.802-685.0	NG Pilot 77623, A3-S, 77623 2SH60
9.803-610.0	NG Electronic Ignition Pilot

**GAS VALVES - 1" BY ROBERT SHAW**

Universal type for new equipment or replacement.



- Manual Gas Cock
- Auto-Pilot Safety Valve
- Wiring and Hardware Included
- Pilot Gas Filter
- 600,000 BTU LP Gas  
720,000 BTU Natural Gas
- 1" Inlet / Outlet

\*Kit is for 8.710-174.0 and includes: gas valve, flame sensor, electrode pilot relight and harness

PART NO.	DESCRIPTION
8.710-179.0	24V AC/NG, Standing Pilot
8.710-174.0	24V AC/NG, Electronic Ignition
8.710-181.0	700 MV, Natural Gas
8.710-163.0*	24V Retrofit Kit (NG) 720,000 BTU
9.802-677.0	Ignition. Ctrl. Module- SP-745 LP Conversion Kit Below

**GAS CONVERSION KITS - LP - ROBERT SHAW**



- Convert NG to LP

PART NO.	DESCRIPTION
8.710-187.0	1" LP Conversion Kit
8.710-164.0	LP Orifice .010

**POWERED DAMPER**



PART NO.	DESCRIPTION
8.749-806.0	Powered Damper, 10"
8.753-171.0	Powered Damper, 12"
8.755-253.0	Powered Damper, 8"
8.749-807.0	Wiring Harness for Powered Damper



## FUEL NOZZLES - DELAVAN - 45° & 60°

Select proper size for maximum burner efficiency.



PART NO.	DESCRIPTION	GPH
<b>45° W HOLLOW</b>		
8.701-013.0	Delavan Fuel Nozzles	2.25
<b>45° A HOLLOW</b>		
8.717-282.0	Delavan Fuel Nozzles	1.00
8.717-285.0	Delavan Fuel Nozzles	1.20
8.701-001.0	Delavan Fuel Nozzles	1.25
8.701-002.0	Delavan Fuel Nozzles	1.35
8.701-003.0	Delavan Fuel Nozzles	1.50
8.701-004.0	Delavan Fuel Nozzles	1.75
8.701-005.0	Delavan Fuel Nozzles	2.00
8.701-014.0	Delavan Fuel Nozzles	2.25
<b>45° B HOLLOW</b>		
8.701-009.0	Delavan Fuel Nozzles	0.90
8.701-008.0	Delavan Fuel Nozzles	1.25
8.700-847.0	Delavan Fuel Nozzles	1.35
8.701-010.0	Delavan Fuel Nozzles	1.50
8.701-012.0	Delavan Fuel Nozzles	2.25
<b>60° W</b>		
8.740-139.0	Delavan Fuel Nozzles	1.25
8.701-007.0	Delavan Fuel Nozzles	1.35
8.701-015.0	Delavan Fuel Nozzles	1.50
8.701-016.0	Delavan Fuel Nozzles	1.65
8.701-017.0	Delavan Fuel Nozzles	1.75
8.701-018.0	Delavan Fuel Nozzles	2.00
8.701-019.0	Delavan Fuel Nozzles	2.25
<b>60° AR</b>		
8.717-286.0	Delavan Fuel Nozzles	1.20
8.717-287.0	Delavan Fuel Nozzles	1.50

PART NO.	DESCRIPTION	GPH
<b>60° A HOLLOW</b>		
8.700-850.0	Delavan Fuel Nozzles	0.50
8.700-851.0	Delavan Fuel Nozzles	0.60
8.700-852.0	Delavan Fuel Nozzles	0.65
8.700-853.0	Delavan Fuel Nozzles	0.85
8.700-854.0	Delavan Fuel Nozzles	0.90
8.700-855.0	Delavan Fuel Nozzles	1.00
8.700-856.0	Delavan Fuel Nozzles	1.10
8.700-857.0	Delavan Fuel Nozzles	1.20
8.700-858.0	Delavan Fuel Nozzles	1.25
8.700-859.0	Delavan Fuel Nozzles	1.35
8.717-328.0	Delavan Fuel Nozzles	1.50
8.700-861.0	Delavan Fuel Nozzles	1.65
8.700-862.0	Delavan Fuel Nozzles	1.75
8.700-863.0	Delavan Fuel Nozzles	2.00
8.700-864.0	Delavan Fuel Nozzles	2.25
8.700-865.0	Delavan Fuel Nozzles	2.50
8.700-866.0	Delavan Fuel Nozzles	2.75
8.700-867.0	Delavan Fuel Nozzles	3.25
8.700-999.0	Delavan Fuel Nozzles	6.00
<b>60° A SOLID</b>		
8.700-868.0	Delavan Fuel Nozzles	0.50
8.700-869.0	Delavan Fuel Nozzles	0.60
8.700-870.0	Delavan Fuel Nozzles	0.75
8.700-871.0	Delavan Fuel Nozzles	0.85
8.700-872.0	Delavan Fuel Nozzles	0.90
8.700-873.0	Delavan Fuel Nozzles	1.00
8.700-874.0	Delavan Fuel Nozzles	1.10
8.700-875.0	Delavan Fuel Nozzles	1.20
8.700-876.0	Delavan Fuel Nozzles	1.25
8.700-877.0	Delavan Fuel Nozzles	1.35
8.700-878.0	Delavan Fuel Nozzles	1.50
8.700-879.0	Delavan Fuel Nozzles	1.65
8.700-880.0	Delavan Fuel Nozzles	1.75
8.700-881.0	Delavan Fuel Nozzles	2.25
8.700-882.0	Delavan Fuel Nozzles	2.50
8.700-883.0	Delavan Fuel Nozzles	2.75
8.700-884.0	Delavan Fuel Nozzles	3.50
8.700-885.0	Delavan Fuel Nozzles	4.00
9.841-677.0	Delavan Fuel Nozzles	6.50
8.700-886.0	Delavan Fuel Nozzles	8.00

**FUEL NOZZLES - DELAVAN - 70°**

Select proper size for maximum burner efficiency.



PART NO.	DESCRIPTION	GPH
<b>70° AR-D</b>		
8.756-261.0	Delavan Fuel Nozzles	1.00
8.756-262.0	Delavan Fuel Nozzles	1.25
8.756-263.0	Delavan Fuel Nozzles	1.50
8.756-264.0	Delavan Fuel Nozzles	1.75
8.756-265.0	Delavan Fuel Nozzles	2.00
<b>70° AR-DZ</b>		
8.755-760.0	Delavan Fuel Nozzles	1.25
8.755-761.0	Delavan Fuel Nozzles	1.50
8.755-762.0	Delavan Fuel Nozzles	1.75
8.755-763.0	Delavan Fuel Nozzles	2.00
<b>70° AZ</b>		
8.755-845.0	Delavan Fuel Nozzles	1.75
<b>70° WZ</b>		
8.755-766.0	Delavan Fuel Nozzles	1.75
8.755-764.0	Delavan Fuel Nozzles	2.00
8.755-765.0	Delavan Fuel Nozzles	2.25

PART NO.	DESCRIPTION	GPH
<b>70° A HOLLOW</b>		
8.700-887.0	Delavan Fuel Nozzles	.50
8.700-888.0	Delavan Fuel Nozzles	.75
8.717-275.0	Delavan Fuel Nozzles	.85
8.717-276.0	Delavan Fuel Nozzles	1.00
9.105-583.0	Delavan Fuel Nozzles	1.10
8.717-277.0	Delavan Fuel Nozzles	1.20
8.723-910.0	Delavan Fuel Nozzles	1.35
8.717-278.0	Delavan Fuel Nozzles	1.50
8.700-892.0	Delavan Fuel Nozzles	1.75
9.106-987.0	Delavan Fuel Nozzles	2.00
8.717-280.0	Delavan Fuel Nozzles	2.25
8.700-893.0	Delavan Fuel Nozzles	2.50
8.700-894.0	Delavan Fuel Nozzles	3.00
8.700-895.0	Delavan Fuel Nozzles	3.25
<b>70° B SOLID</b>		
8.700-896.0	Delavan Fuel Nozzles	.75
8.700-897.0	Delavan Fuel Nozzles	1.00
8.700-898.0	Delavan Fuel Nozzles	1.20
8.700-899.0	Delavan Fuel Nozzles	1.25
8.700-900.0	Delavan Fuel Nozzles	1.35
8.700-901.0	Delavan Fuel Nozzles	1.50
8.700-902.0	Delavan Fuel Nozzles	1.65
8.700-903.0	Delavan Fuel Nozzles	1.75
8.700-904.0	Delavan Fuel Nozzles	2.00
8.700-905.0	Delavan Fuel Nozzles	2.25
8.700-906.0	Delavan Fuel Nozzles	2.50
8.700-907.0	Delavan Fuel Nozzles	3.50
8.700-908.0	Delavan Fuel Nozzles	4.00
8.700-909.0	Delavan Fuel Nozzles	5.00
8.700-910.0	Delavan Fuel Nozzles	8.00

**FUEL NOZZLES - DELAVAN - 80°**

Select proper size for maximum burner efficiency.

PART NO.	DESCRIPTION	GPH
<b>80° W</b>		
8.723-697.0	Delavan Fuel Nozzles	.85
8.723-698.0	Delavan Fuel Nozzles	.90
8.701-022.0	Delavan Fuel Nozzles	1.00
8.723-699.0	Delavan Fuel Nozzles	1.10
8.723-700.0	Delavan Fuel Nozzles	1.20
8.701-027.0	Delavan Fuel Nozzles	1.25
8.723-701.0	Delavan Fuel Nozzles	1.35
8.701-021.0	Delavan Fuel Nozzles	1.50
8.701-020.0	Delavan Fuel Nozzles	1.65
8.701-023.0	Delavan Fuel Nozzles	1.75
8.717-342.0	Delavan Fuel Nozzles	2.00
8.701-025.0	Delavan Fuel Nozzles	2.25
8.701-026.0	Delavan Fuel Nozzles	2.50
8.701-028.0	Delavan Fuel Nozzles	2.75
8.701-029.0	Delavan Fuel Nozzles	3.00
8.701-030.0	Delavan Fuel Nozzles	3.25
8.701-031.0	Delavan Fuel Nozzles	3.50
8.701-036.0	Delavan Fuel Nozzles	4.00
<b>80° AZ</b>		
8.754-928.0	Delavan Fuel Nozzles	1.25
8.754-894.0	Delavan Fuel Nozzles	1.35
8.755-198.0	Delavan Fuel Nozzles	1.50
8.756-364.0	Delavan Fuel Nozzles	1.75
8.755-197.0	Delavan Fuel Nozzles	2.00
8.756-330.0	Delavan Fuel Nozzles	2.25
<b>80° BZ</b>		
8.756-861.0	Delavan Fuel Nozzles	1.00
8.756-718.0	Delavan Fuel Nozzles	1.25
8.756-723.0	Delavan Fuel Nozzles	1.50
8.756-015.0	Delavan Fuel Nozzles	1.75
8.756-699.0	Delavan Fuel Nozzles	2.00
8.756-759.0	Delavan Fuel Nozzles	2.25
8.756-900.0	Delavan Fuel Nozzles	2.50
8.756-491.0	Delavan Fuel Nozzles	2.75
8.754-893.0	Delavan Fuel Nozzles	3.00
8.755-048.0	Delavan Fuel Nozzles	3.25
8.755-049.0	Delavan Fuel Nozzles	3.50
8.756-697.0	Delavan Fuel Nozzles	4.00
<b>80° A HOLLOW</b>		
8.700-911.0	Delavan Fuel Nozzles	.50
8.700-912.0	Delavan Fuel Nozzles	.60
8.700-913.0	Delavan Fuel Nozzles	.65
8.700-914.0	Delavan Fuel Nozzles	.75
8.700-915.0	Delavan Fuel Nozzles	.85
8.717-333.0	Delavan Fuel Nozzles	.90

PART NO.	DESCRIPTION	GPH
<b>80° A HOLLOW (CONTINUED)</b>		
8.700-916.0	Delavan Fuel Nozzles	1.00
8.700-917.0	Delavan Fuel Nozzles	1.10
8.717-323.0	Delavan Fuel Nozzles	1.20
8.700-919.0	Delavan Fuel Nozzles	1.25
9.802-584.0	Delavan Fuel Nozzles	1.35
8.700-921.0	Delavan Fuel Nozzles	1.50
8.700-922.0	Delavan Fuel Nozzles	1.65
8.717-329.0	Delavan Fuel Nozzles	1.75
8.700-924.0	Delavan Fuel Nozzles	2.00
8.717-347.0	Delavan Fuel Nozzles	2.25
8.700-926.0	Delavan Fuel Nozzles	2.50
8.700-927.0	Delavan Fuel Nozzles	2.75
8.700-928.0	Delavan Fuel Nozzles	3.00
8.700-929.0	Delavan Fuel Nozzles	3.50
8.700-930.0	Delavan Fuel Nozzles	4.00
8.717-331.0	Delavan Fuel Nozzles	4.50
<b>80° B SOLID</b>		
8.700-931.0	Delavan Fuel Nozzles	.50
8.700-932.0	Delavan Fuel Nozzles	.60
8.700-933.0	Delavan Fuel Nozzles	.65
8.700-934.0	Delavan Fuel Nozzles	.75
8.700-935.0	Delavan Fuel Nozzles	.85
8.700-936.0	Delavan Fuel Nozzles	.90
8.700-937.0	Delavan Fuel Nozzles	1.00
8.700-938.0	Delavan Fuel Nozzles	1.10
8.700-939.0	Delavan Fuel Nozzles	1.20
8.717-350.0	Delavan Fuel Nozzles	1.25
8.717-358.0	Delavan Fuel Nozzles	1.35
8.717-351.0	Delavan Fuel Nozzles	1.50
8.700-943.0	Delavan Fuel Nozzles	1.65
8.717-352.0	Delavan Fuel Nozzles	1.75
8.717-353.0	Delavan Fuel Nozzles	2.00
8.700-946.0	Delavan Fuel Nozzles	2.25
8.700-947.0	Delavan Fuel Nozzles	2.50
8.717-330.0	Delavan Fuel Nozzles	2.75
8.717-354.0	Delavan Fuel Nozzles	3.00
8.700-950.0	Delavan Fuel Nozzles	3.25
8.700-951.0	Delavan Fuel Nozzles	3.50
8.700-952.0	Delavan Fuel Nozzles	4.00
8.717-367.0	Delavan Fuel Nozzles	4.50
8.717-357.0	Delavan Fuel Nozzles	5.00
8.700-956.0	Delavan Fuel Nozzles	6.00
8.700-953.0	Delavan Fuel Nozzles	6.50
8.700-957.0	Delavan Fuel Nozzles	8.00
8.700-958.0	Delavan Fuel Nozzles	8.50
8.700-959.0	Delavan Fuel Nozzles	9.00

**FUEL NOZZLES - DELAVAN - 90°**

Select proper size for maximum burner efficiency.



PART NO.	DESCRIPTION	GPH
<b>90° W</b>		
8.701-006.0	Delavan Fuel Nozzles	1.00
8.701-037.0	Delavan Fuel Nozzles	1.35
8.701-038.0	Delavan Fuel Nozzles	1.50
8.701-039.0	Delavan Fuel Nozzles	1.65
8.701-023.0	Delavan Fuel Nozzles	1.75
8.701-032.0	Delavan Fuel Nozzles	2.00
8.701-034.0	Delavan Fuel Nozzles	2.25
8.701-035.0	Delavan Fuel Nozzles	2.75
<b>90° AZ</b>		
8.754-890.0	Delavan Fuel Nozzles	1.00
8.754-891.0	Delavan Fuel Nozzles	1.50
8.754-953.0	Delavan Fuel Nozzles	1.75
8.755-053.0	Delavan Fuel Nozzles	2.00
8.755-030.0	Delavan Fuel Nozzles	2.25
8.755-052.0	Delavan Fuel Nozzles	2.75
8.755-051.0	Delavan Fuel Nozzles	4.00
<b>90° BZ</b>		
8.754-895.0	Delavan Fuel Nozzles	1.25
8.756-179.0	Delavan Fuel Nozzles	1.35
8.754-916.0	Delavan Fuel Nozzles	1.50
8.754-888.0	Delavan Fuel Nozzles	2.00
8.754-889.0	Delavan Fuel Nozzles	2.25
8.754-986.0	Delavan Fuel Nozzles	2.75
<b>90° A HOLLOW</b>		
8.700-960.0	Delavan Fuel Nozzles	.60
8.700-961.0	Delavan Fuel Nozzles	.65
8.700-962.0	Delavan Fuel Nozzles	.75
8.723-911.0	Delavan Fuel Nozzles	.85
8.700-963.0	Delavan Fuel Nozzles	.90
9.802-583.0	Delavan Fuel Nozzles	1.00
8.717-332.0	Delavan Fuel Nozzles	1.10
8.700-966.0	Delavan Fuel Nozzles	1.25
8.700-967.0	Delavan Fuel Nozzles	1.35
9.802-585.0	Delavan Fuel Nozzles	1.50
8.700-969.0	Delavan Fuel Nozzles	1.65

PART NO.	DESCRIPTION	GPH
<b>90° A HOLLOW (CONTINUED)</b>		
8.700-970.0	Delavan Fuel Nozzles	1.75
8.700-971.0	Delavan Fuel Nozzles	2.00
8.700-972.0	Delavan Fuel Nozzles	2.25
8.700-973.0	Delavan Fuel Nozzles	2.50
8.700-974.0	Delavan Fuel Nozzles	2.75
8.700-975.0	Delavan Fuel Nozzles	3.00
8.717-336.0	Delavan Fuel Nozzles	3.25
8.700-977.0	Delavan Fuel Nozzles	3.50
8.700-978.0	Delavan Fuel Nozzles	4.00
8.717-338.0	Delavan Fuel Nozzles	4.50
8.700-979.0	Delavan Fuel Nozzles	5.00
8.700-980.0	Delavan Fuel Nozzles	6.00
<b>90° B SOLID</b>		
8.700-981.0	Delavan Fuel Nozzles	.50
8.700-982.0	Delavan Fuel Nozzles	.75
8.700-983.0	Delavan Fuel Nozzles	.85
8.700-984.0	Delavan Fuel Nozzles	1.00
8.700-985.0	Delavan Fuel Nozzles	1.10
9.802-582.0	Delavan Fuel Nozzles	1.25
8.700-987.0	Delavan Fuel Nozzles	1.35
8.700-988.0	Delavan Fuel Nozzles	1.50
8.700-989.0	Delavan Fuel Nozzles	1.65
9.802-575.0	Delavan Fuel Nozzles	1.75
9.802-576.0	Delavan Fuel Nozzles	2.00
9.802-577.0	Delavan Fuel Nozzles	2.25
9.802-586.0	Delavan Fuel Nozzles	2.50
8.700-994.0	Delavan Fuel Nozzles	2.75
8.700-995.0	Delavan Fuel Nozzles	3.00
8.700-996.0	Delavan Fuel Nozzles	3.25
8.700-997.0	Delavan Fuel Nozzles	3.50
8.700-998.0	Delavan Fuel Nozzles	4.00
8.717-374.0	Delavan Fuel Nozzles	4.50
8.701-000.0	Delavan Fuel Nozzles	6.00



## FUEL NOZZLES - CHECK VALVE - "SNAP"

Spring-loaded "snap" check valve replaces filter element on fuel nozzle. Valve opens when fuel pump pressure reaches 130 PSI and "snaps" shut when fuel pressure drops below 130 PSI. Stops "smokey" burners at start-up and eliminates "shutdown" after burn and reduces soot build-up in coil.

- Reduces nozzle fouling caused by residual fuel in orifice
- Easy field installation in standard fuel nozzles



PART NO.	DESCRIPTION	PSI
8.900-083.0	Snap Fuel Valve	100
8.900-084.0	Snap Fuel Valve	130
8.700-845.0	Snap Check Valve, 5/PK	130
8.700-844.0	Snap Check Valve, 5/PK	100

## GAS VALVES - LP OR NATURAL

Universal-type for building new systems or field replacement. 750 MV, 24V or 120V controls by White-Rogers.



- 335,000 BTU Max
- 3/4" Inlet / Outlet
- All adjustments and wiring connections on top of valve
- Automatic Outlet Pressure Regulator
- A.G.A. Design Certified, C.G.A. Certified



PART NO.	DESCRIPTION
8.710-172.0	Universal, 24V, Includes LP Conv. Kit (1)
8.710-182.0	Universal 120V, Includes LP Conv. Kit (2)
8.710-183.0	Universal, Standing Pilot, 750 MV (1)
8.750-110.0	3/4" NG to LP Conversion Kit
8.750-109.0	3/4" LP to NG Conversion Kit

### WHITE-RODGERS REPAIR PARTS

8.710-184.0	24V Cycle Pilot Control (347425), 1/4" Spade Terminals, High Voltage
8.710-198.0	Gas Ignition Electrode with Universal Mounting Bracket & 24" Lead

(1) Includes two 3/4" x 1/2" all-thread plated bushings and valve instructions. (2) Includes L.P. Kit, two 3/4" x 1/2" and one 1/2" x 3/8" all-thread plated bushings and all instructions.

## GAS VALVE ACCESSORY COMPONENTS

Use with both 3/4" and 1" models on this page.



8.710-190.0



PART NO.	DESCRIPTION
8.710-190.0	600/750 MV Generator 36" Length
8.710-191.0	Pilot, Universal-Kit with Standard Flame
8.718-092.0	Thermocouple, Universal, 24" Length, Cap Tube
8.710-196.0	Thermocouple, Universal, 36" Length, Cap Tube
9.802-686.0	Thermopile VNG, with Spade Terminals, 47" Length



**INSULATION AND RIGID DISC / DONUTS**

Refractory-grade ceramic Kaowool formed; retains heat inside coil for better fuel efficiency and paint protection.



PART NO.	DESCRIPTION	THICKNESS	WIDTH	LENGTH
<b>"RIGID FORMED" DONUT AND DISCS</b>				
8.704-807.0	Donut	.88"	18" 6"/4	4"
8.704-810.0	Donut	.88"	16" 6"/4	4"
8.717-474.0	Donut		24"	
8.704-808.0	Disc	1/2"	18"	
8.704-809.0	Disc	1/2"	16"	
8.717-475.0	Disc		24"	
<b>INSULATION BLANKET</b>				
8.901-288.0	Coil Wrap	1"	24"	4'
8.901-289.0	Coil Wrap	1"	24"	5'
8.704-800.0	Coil Wrap	1"	24"	6'
8.704-802.0	 Full Roll	1/2"	24"	37.5'
8.704-805.0	 Full Roll	1"	24"	25'



## FLOW SWITCHES - LEGACY MV60 & AP500



- Temperature: 180°F
- AMP: 3, 12-250V
- Horizontal & Vertical Mount
- 3/8" FPT Inlet / Outlet
- 2 Wire Reed
- 62" Cord Length

PART NO.	DESCRIPTION	PSI	GPM
8.933-006.0	MV-60, Vertical or Horizontal Mount	5660	10.0
8.712-244.0	AP-500, Vertical Mount Only	4350	8.0
9.803-266.0	Reed Switch (AP) (2 wire)		

## FLOW SWITCHES - ST-5 & ST-6



ST-5



ST-6

- Temperature: 180°F
- Brass Body

PART NO.	DESCRIPTION
9.112-680.0	ST-5 Gray, Vertical/ Horizontal Mount, 75-5075 PSI Max, 1-7.8 GPM, 3/8" FPT Inlet/Outlet, 1 A-250 V (47" Wire Length)
8.757-669.0	ST-5 Black, Vertical Mount, 75-4380 PSI Max, 1-8 GPM, 3/8" FPT Inlet/Outlet, Contact: 1A-250V (48" Wire Length)
8.757-668.0	ST-6 Vertical/Horizontal Mount, 75-5075 PSI Max, 1-8 GPM, 3/8 MPT Inlet/Outlet, 1 A-250 V (47" Wire Length)
8.757-670.0	Reed Switch for ST-5 and ST-6 New Style

## FLOW SWITCHES - PHOENIX WITH PILOT



- PSI: 18 - 4000
- GPM: .75 - 16.0
- Temperature: 190°F
- AMP: 3, 120V
- 3/8" F Inlet / Outlet Ports
- 96" Reed Cord
- Includes 8 mm Pilot
- 2.5 lbs.
- Mounting Hole

PART NO.	DESCRIPTION
8.712-252.0	Switch with Pilot
8.712-253.0	Reed Switch

## FLOW SWITCHES - LEGACY

Spring return float allows full mounting versatility.



- PSI: 4050
- Rated Pressure: 3650
- GPM: 8.0
- Temperature: 175°F
- Vertical Mount
- Forged Brass Body
- 3/8" MPT Inlet / Outlet
- 1 Amp Switch, 230V, 36" Cord
- Solenoid Control

PART NO.	DESCRIPTION
8.712-246.0	Flow Switch

## FLOW SWITCHES - ST-7 WITH MICRO SWITCH



- PSI: 5000
- GPM: 12.0
- Temperature: 176°F
- 3/8" FPT Inlet / Outlet
- Micro Switch
- 10.1 A- 250 V

PART NO.	DESCRIPTION
8.755-296.0	ST-7 Horizontal or Vertical Mount (47" Wire Length)

## FLOW SWITCHES - GP - TMT



- PSI: 5000
- GPM: 1.5 at PSI: 50
- Minimal Pressure Drop up to 12 GPM Flow
- Activates with 1.5 GPM Flow
- Temperature: 40° - 180°F
- AMP: 5, 250V
- 3/8" F Inlet / Outlet Ports
- 48" Electrical Lead Length
- 1.0 lbs.
- Can be mounted in any position
- Micro-Switch technology eliminates reed switch
- No Spring, uses Magnets for all Movements

PART NO.	DESCRIPTION
8.712-258.0	Inline Flow Switch

**FLOW SWITCHES - ST-505 STAINLESS-STEEL**



- PSI: 75 - 8700
- GPM: 1.0 - 8.0
- Temperature: 176°F
- 3/8" FPT Inlet / Outlet
- Stainless-steel
- 3 A, Max/ 250 V Max
- Free floating brass magnet

PART NO.	DESCRIPTION
8.723-665.0	ST-505 Vertical Mount, 47" Lead

**VAC SWITCHES - BURNER CONTROL**

Normally open (NO) switch closes when pump vacuum begins drawing water and opens when vacuum is broken due to pump shutdown or empty water tank.



- Temperature Max: 140°F
- Heavy-duty, 16 Amp Contacts
- 1/4" FPT Connect

PART NO.	DESCRIPTION
8.712-391.0	1.5" (HG) Vac Switch
8.712-392.0	2.5" (HG) Vac Switch
8.712-393.0	4.5" (HG) Vac Switch

**PRESSURE SWITCHES - LEGACY**



Operation without opening switch case:  
Blue = Common  
CONNECT: Red / Blue = N/C, Blue / Brown = N/O



- PSI: 3600
- Temperature: 200°F
- AMP: 15, 115V or 230V AC
- Stainless-Steel Plunger
- 1/4" and 3/8" MPT Nipple
- 3 Wire, Internally Wired for either N/O or N/C
- 42" Wire Length

PART NO.	DESCRIPTION
8.712-261.0	Pressure Switch (Switches @ 360 PSI)
8.712-262.0	Pressure Switch 1/4" MPT (Switches @ 580 PSI)
8.751-272.0	Pressure Switch 3/8" (Switches @ 580 PSI)
8.701-311.0	V7 Series Micro Switch (15 AMP 120/250V AC)

**PRESSURE SWITCHES - COMPACT & PS-6 SS**

3- & 5-Amp rating provides the switching power to control fuel solenoids just like the large switches.



- Temperature: 194°F
- 1/4" Brass MPT Connect
- 3 Wire Cable for use in either NC or NO application:  
Blue = Common  
Brown = No  
Red = NC

PART NO.	DESCRIPTION
8.712-260.0	Compact Switch- 54" 2 Wire Lead, Normally Open, 5 A- 250 V, 725-3000 Max PSI
8.712-270.0	PS-6 Switch- 16 A- 250 V, 47" 3 Wire Lead, 4060 PSI MAX, 435 Switching Pressure, SS Plunger

**PRESSURE SWITCHES - PR16 - BLACK**



- Rated PSI: 3625  
Max PSI: 4060
- Switching Pressure PSI: 580
- Temperature: 195°F
- AMP: 16, 250V
- 1/4" Male Inlet
- Brass Stem and Stainless-Steel Nipple
- 45" Wire Length
- 8 oz.
- Normally Open

PART NO.	DESCRIPTION
9.802-458.0	PR16 - Black Pressure Switch

**PRESSURE SWITCHES - PA - PR1 - RED**



- Rated PSI: 8700  
Max PSI: 9570
- Switching Pressure PSI: 640
- Temperature: 195°F
- AMP: 15, 250V
- All Stainless-Steel Construction
- 3/8" Male Inlet
- 10 oz.
- 44" Wire Length

PART NO.	DESCRIPTION
8.712-267.0	PR1 - Red Pressure Switch
8.704-572.0	Heavy-duty Micro Switch



**SWITCHES - TOGGLE - PUSH BUTTON**



- 7/16" Mounting Bushing
- 1/2" Diameter Mounting Hole Required
- Mounting Hardware Included
- Non-Illuminated

PART NO.	DESCRIPTION	HP*	CONNECTS
8.712-319.0*	SPST, 20A/125V -10A/250V AC	1.0	M/Spade
8.712-320.0	DPST, 20A/125V -10A/250V AC		M/Spade
8.709-705.0*	DPST, 20A/125V -10A/250V AC	1.5	Screw
8.709-704.0*	DPST, 20A/250V	2.0	Screw
8.709-054.0*	SPDT, 20A/125V -10A/250V AC	3/4	M/Spade
8.709-065.0*	DPDT, 20A/125V -10A/250V AC	3/4	M/Spade
8.716-078.0	SPST, 20A/125V -10A/250V AC	1.5	
8.709-706.0	Y500 - Switch Guard		
8.716-081.0	Waterproof Switch Protector		
PUSH BUTTON SWITCHES			
8.709-053.0	SPST, 3A/250V-6A/125V AC, Miniature- Push Button On/Off		Screw
8.709-064.0	SPST, 15A/125V AC, Push Button On/Off		Screw

\*Motor Rated

**SWITCHES - TOGGLE - MOTOR CONTROL**



- 20/30 A, 250/600 V DPST
- Rated For: 2, 3, 5 & 7.5 HP, Single Phase
- With or Without Box

PART NO.	DESCRIPTION
8.709-696.0	Switch Only
8.903-802.0	Switch & Rain Tight Box with Cover
8.709-708.0	Switch with NEMA 1 Enclosure: Not Rain Tight (Baldor Replacement)

**SWITCHES - THERMAL - HI-LIMIT - SNAP**



8.712-306.0

- PSI: 4000
- AMP: 15 at 110V, AMP: 10 at 220V
- 1/4" Male Spade Lug Terminals
- Normally Closed
- UL / CSA Rated, Bimetal Switch Componentets
- Heavy-Duty Brass Housing - 7000 PSI Collapse Rating
- Normally used with other adjustable or fixed range thermostat which regulates water temperature
- Does not turn back on until water has cooled 50° - 70°F
- Operates as a safety device to shut off burner to prevent machine (water) overheating flashing to steam

PART NO.	PROBE MPT	TEMP
8.712-301.0	3/8" x 1/2"	120°F
8.712-206.0	3/8"	140°F
8.753-450.0	3/8"	160°F
8.712-306.0	3/8" x 1/2"	180°F
8.712-311.0	3/8" x 1/2"	230°F
8.712-179.0	1/2"	180°F
8.712-308.0	1/2"	210°F
8.712-298.0	1/2"	230°F
8.712-316.0	1/2"	330°F
8.705-351.0	1/2" FPT x FPT	PVC Coupler

**SWITCHES - THERMAL - HI-LIMIT - SNAP WITH LEADS**



- AMP: 15 at 110V, AMP: 10 at 220V
- 1/4" Male Spade Lug Terminals
- 1/2" MPT external thread connects for attaching conduit or PVC wire connectors
- UL / CSA Rated, Bimetal Switch Componentets
- Does not turn back on until water has cooled 50° - 70°F
- Heavy-Duty Brass Housing - 7000 PSI Collapse Rating
- Normally used with other adjustable or fixed range thermostat which regulates water temperature
- Operates as safety device to shut off burner to prevent machine (water) overheating flashing to steam

PART NO.	PROBE MPT	WIRE LEAD	TEMP
8.712-185.0	1/2"	42"	225°F
8.712-205.0	1/2"	42"	340°F
8.751-363.0	1/2"	36" SJO 3 Wire	180°F
8.712-187.0	1/2"	42"	275°F

## CONNECTORS - DP - CUTLER-HAMMER

Cutler-Hammer



- Cutler-Hammer Quality
- Type C25 definite purpose contactors feature a compact, efficient design with low-VA coil
- Din Rail Mounting

PART NO.	COIL VOLTAGE	FL AMPS	MOTOR HP @ 115V 1PH	MOTOR HP @ 230V 1PH	MOTOR HP @ 230V 3PH	MOTOR HP @ 460V 3PH	MOTOR HP @ 575V 3PH
8.724-267.0	24V	15	.75	2	3	5	5
8.724-264.0	115V	15	.75	2	3	5	5
8.724-265.0	230V	15	.75	2	3	5	5
8.724-266.0	460V	15	.75	2	3	5	5
8.724-269.0	24V	25	2	3	7.5	10	10
8.724-268.0	115V	25	2	3	7.5	10	10
8.724-270.0	230V	25	2	3	7.5	10	10
8.724-271.0	460V	25	2	3	7.5	10	10
8.724-275.0	24V	30	2	5	10	15	15
8.724-272.0	115V	30	2	5	10	15	15
8.724-273.0	230V	30	2	5	10	15	15
8.724-274.0	380V	30	2	5	10	15	15
8.724-280.0	24V	40	3	7.5	10	20	20
8.724-276.0	115V	40	3	7.5	10	20	20
8.724-277.0	230V	40	3	7.5	10	20	20
8.724-279.0	380V	40	3	7.5	10	20	20
8.724-278.0	460V	40	3	7.5	10	20	20
8.724-283.0	24V	50	3	10	15	30	30
8.724-281.0	115V	50	3	10	15	30	30
8.724-282.0	230V	50	3	10	15	30	30
8.724-286.0	24V	60	5	10	20	40	40
8.724-284.0	115V	60	5	10	20	40	40
8.724-285.0	230V	60	5	10	20	40	40
8.735-015.0	115V	65	5	15	25	50	60

## SWITCHES / CONTACT BLOCKS - PUSH BUTTON - CUTLER-HAMMER

Cutler-Hammer

- Cutler-Hammer Quality
- Heavy-Duty
- Water Tight / Oil Tight



8.751-916.0



8.751-915.0



8.751-910.0



8.751-912.0

PART NO.	MODEL NO.	DESCRIPTION
9.803-666.0	CH C320KGS3	Aux Contact-N/O, N/C, 10A, Standard, Side Mounting
8.751-912.0	M22-K01	Contact Block-SPST-NC, 6A, 120V, Screw Terminal
8.751-913.0	M22-K10	Contact Block-SPST-NO for Non-Illum., Push Button, 6A, 500V, Screw Terminal
8.751-916.0	M22S-D-G	Switch, Green Push Button-SPST-NO, 22mm, Momentary, Flush Button, 6A, 500V, Screw Clamp Term.
8.751-915.0	M22S-DH-R	Switch, Red Push Button- SPST-NO/NC, 22mm, Momentary, Extended Button, 6A, 500V
8.751-910.0	M22S-WKV	Selector Switch Actuator- 22mm, 2 Position, Maintained, Non-Illum, Panel Mount

## OVERLOAD RELAYS FOR CONTRACTORS

Cutler-Hammer



- Cutler-Hammer Quality
- Direct Heated Bimetal Elements
- Adjustable Trip Current
- Manual / Automatic Reset

PART NO.	AMP RANGE	MODEL #
8.724-297.0	0.4 - 0.6	XTOBP60CC1DP
8.724-298.0	0.6 - 1.0	XTOB001CC1DP
8.724-300.0	1.6 - 2.4	XTOB2P4CC1DP
8.724-301.0	2.4 - 4.0	XTOB004CC1DP
8.724-302.0	4.0 - 6.0	XTOB006CC1DP
8.724-303.0	6.0 - 10.0	XTOB010CC1DP
8.724-312.0	10.0 - 16.0	XTOB016CC1DP
8.724-304.0	16.0 - 24.0	XTOB024CC1DP
8.724-305.0	24.0 - 32.0	XTOB032CC1DP
8.724-306.0	24.0 - 40.0	XTOB040DC1DP
8.724-307.0	40.0 - 57.0	XTOB057DC1DP

## RELAY SWITCH



PART NO.	DESCRIPTION
8.716-087.0	DPST-NO, 24V, Screw Terminal, Omron 2000 Series

## POWER CORD - MOLDED

- Water Tight
- Factory Finished Look

PART NO.	DESCRIPTION
8.752-150.0	6' 14/3 with Plug

## RELAYS



9.802-468.0



8.716-230.0



9.802-467.0



9.802-470.0



8.716-264.0



8.716-257.0

PART NO.	DESCRIPTION
9.802-468.0	Compact Relay with Light & Button- 10A, 120V, 4170 Ohms with indicator, DPDT, Socketable Mount RH2B UI AC120
8.716-209.0	Relay with Indicator Light- 10A, 24V AC, Midget, 153 Ohms, DPDT, Socketable Mount
9.802-467.0	Relay Socket/Base- 8 Pin, 2 Pole, 10A / 300V, DIN Rail Mount, M3.5 Screw, RH2B Series
8.716-230.0	Relay- 10A/24V AC, Midget, 153 Ohms, DPDT, Socketable Mount, RH2B
8.716-264.0	Power Relay-120V, Tab Mount, 30A SPST-NO-DM, 1/4" Terminals for SKHT-1X
8.716-257.0	Power Relay- 40A / 120V AC, SPDT, PCB/Chassis Mount
9.802-470.0	Mini Iso Relay- 40A / 12V, SPDT, for 12V DC Units, 13HP & Below
9.802-471.0	Mini Relay- 40A / 24V DC, SPDT, for 12V DC Units over 13HP

## CAM SWITCHES - ROTARY - SALZER

- Single or Three Phase
- 2 Position or 3 Position
- Heavy-Duty



9.802-449.0

PART NO.	DESCRIPTION
9.802-450.0	2-Position 35A-115V/600V, 1-3 Phase
9.802-449.0	3-Position 115V / 230V, 1PH, 20 Amp
8.716-027.0	3-Position 230V / 460V, 3PH
8.716-030.0	Rotary Switch



**MOTOR CONTACTORS - COILS & THERMAL OVERLOADS**

For pressure washer and car wash applications.

- 24V AC Control
- 10 - 240V, 30 - 240V or 480V Contractor
- Componentized for Flexibility
- Thermal overloads adjustable within range shown
- Electrical Life: 1,000,000 + Cycles
- Mechanical Life: 20,000,000 + Cycles
- Contacts: 90% Silver, 10% Cad-Oxide



**Contactor**



**Coil**



**Thermal Overload**

TYPE	24V COIL PART NO.	120V COIL PART NO.	230V COIL PART NO.	FL AMP	220V 10 HP	220V 30 HP	440V 30 HP	
<b>CONTACTORS UL RATING</b>								
A	8.708-753.0	8.902-527.0	\$121.00	8.902-532.0	22	2	3	5
B	8.708-754.0	8.902-528.0	\$119.00	8.902-533.0	24	2	5	7.5
C	8.902-523.0	8.902-529.0	\$194.00	8.902-534.0	32	3	5	10
D	8.902-524.0	8.902-530.0	\$208.00	-	40	5	7.5	15
E	8.902-526.0	8.902-531.0	\$259.00	8.902-536.0	52	7.5	10	20

PART NO.	VOLTAGE	FITS CONTACTOR
<b>COILS ONLY</b>		
8.708-764.0	24v	A,B,C,D
8.708-765.0	480v	A,B,C,D
8.708-767.0	220v	E

PART NO.	TYPE	AMP RANGE	FITS CONTACTOR
<b>THERMAL OVERLOADS</b>			
8.708-749.0	Manual	9.0 - 15	A,B,C,D
8.708-760.0	Manual	17 - 26	A,B,C,D
8.708-742.0	Manual	20 - 33	C,D
8.708-744.0	Manual	28 - 42	C,D
8.708-750.0	Auto	9.0 - 15	A,B,C,D
8.708-759.0	Auto	14 - 23	A,B,C,D
8.708-743.0	Auto	20 - 33	C,D
8.708-747.0	Auto	35 - 50	E,F

- Used to Mount Overload to Motor Starter Contactors

PART NO.	FITS CONTACTOR	
<b>RELAY CONNECTOR KIT</b>		
8.708-768.0	Relay Connector Kit 260265-268	A,B,C,D



## TRANSFORMERS - STEP-DOWN

■ Industrial Duty

■ High-Quality Cutler-Hammer

■ Drops primary voltage to selected secondary voltage



8.716-899.0



9.802-553.0



8.716-904.0

PART NO.	PRIMARY V	SECONDARY V	SIZE
8.716-899.0	380V/400V/415V	110/220V	.750KvA
9.802-553.0	120V/240V	24V	.050KvA
8.716-904.0	120V/240V	24V	.100KvA
8.716-883.0	208V/230V/460V	24V/115V	.050KvA
9.804-556.0	208V/277V	120V	.050KvA
8.716-882.0	208V/277V	120V	.075KvA
9.803-971.0	380V	24V	.050KvA
9.802-550.0	240V/480V	120V/240V	.500KvA
9.802-552.0	240V/480V	120V	.075KvA
9.802-551.0	240V/480V	120V	.050KvA
9.803-668.0	550V/575V/600V	115V	.050KVA

## MOTOR STARTER WITH SEALED BOX - MANUAL

■ AMP: 25 with Adjustable Overload

■ Two-Cord Grip Fit 1/2" Threaded Knockouts

■ Adjustment Range AMPS: 20-25

■ Protective Cover Over Buttons

■ Sealed Box: 3-1/4" W x 3-1/2" D x 6-1/2" H

■ Single and 3-Phase Wiring Instructions

■ 110-500V IEC-Rated



PART NO.	DESCRIPTION
8.709-709.0	Motor Starter

**JUNCTION BOXES**



PART NO.	DESCRIPTION
9.802-474.0	VNG Remote, Plastic
8.716-269.0	12" x 12" x 4", Metal VNG Remote Box
8.716-271.0	Fiberglass, NEMA1 for PE Units
8.716-272.0	12" x 10" x 5.25" for Solid Sep
9.802-475.0	8" x 8" x 4", Box, Plastic with Lid for SEA 3-1100
9.802-476.0	10" x 8" x 6", Box, Plastic with Lid for SEA
9.802-477.0	Box, Plastic without Lid E9081
9.802-478.0	Lid, Plastic for 9.802-477.0
8.716-280.0	18" x 16" x 9.25", Plastic for CLP, WB
8.716-281.0	14" x 16" x 6.75", Plastic for HBG, AMC
8.716-320.0	Cover, Duplex Receptacle for Alpha
8.716-321.0	2" x 4", 3-Hole, 1/2" WB, for CLP
8.716-322.0	2" x 4", Extension for 8.716-321.0, 8.716-323.0, 8.716-324.0
8.716-323.0	2" x 4", 5-Hole, 1/2" for CLP
8.716-324.0	2" x 4", 4-Hole, 1/2" for CLP
8.716-326.0	4" x 4", 3-Hole, SK Series for Alpha / PK
8.716-327.0	4" x 4", 5-Hole, 1/2" for WB
8.716-329.0	4" x 4" SK, Cover Plate for WB for 6-00041
9.802-483.0	2" x 4", Cover Plate for 8.716-321.0
9.802-484.0	2" x 4", Junction 3-Hole, 3/4"
8.716-339.0	2" x 4", 3-Hole, 1" for ENG

**SWITCH BOX - RAIN TITE**

- UL 728A
- Box: 2-3/4" x 5-1/2" x 2"
- Three 1/2" Tapped Holes
- Box includes two plugs, ground screw and mounting lugs
- Cover Includes Gasket



PART NO.	DESCRIPTION
8.709-702.0	RainTite Switch Box



## TIMER

- Preset and Adjustable Available
- 24-240V
- Heavy-Duty



PART NO.	DESCRIPTION
9.802-472.0	Solid State, 5-60 Min, 15 Sec with Lockout for Auto Start

## CIRCUIT BREAKERS

- Provides protection against excessive Amp draw



PART NO.	DESCRIPTION
9.802-485.0	25 Amp (All 12V Systems)

## FUSES

- Full range of fuses
- Protect your equipment



PART NO.	CODE	MAX V	AMPS
9.802-463.0	FNM1/2	250V	0.5
9.802-464.0	FNM8/10	250V	0.8
8.716-173.0	FNM1	250V	1.0
9.803-977.0	FNM2-1/2	250V	2.5
8.716-187.0	FNM3	250V	3.0
9.803-664.0	FNM5	250V	5.0
8.716-194.0	FNM7	250V	7.0
9.802-460.0	FNM8	250V	8.0
8.716-165.0	FNM10	250V	10.0
8.716-191.0	FNQ3/10	500V	0.3
8.716-192.0	FNQ6/10	500V	0.6
9.802-465.0	FNQ-R-3	600V	3.0
8.716-169.0	KTK-R1/4	600V	0.25
9.802-462.0	KTK-R1/2	480V	0.5
8.933-007.0	KTK-R1	240V	1.0
8.716-177.0	KTK-R1-1/2	600V	1.5
9.803-663.0	KTK-R2	120V	2.0
8.716-179.0	KTK-R2-1/2	600V	2.5
8.716-180.0	KTK-R4	600V	4.0
9.804-050.0	KTK-R5	600V	5.0
8.716-183.0	KTK-R30	600V	30.0
8.716-170.0	MDL1/2	120V	0.5
8.716-175.0	MDL3/4	250V	0.75
8.716-172.0	MDL1	250V	1.0
8.716-174.0	MDL2-1/2	24V	2.5
8.716-186.0	MDL3	250V	3.0
8.716-188.0	MDL5	250V	5.0
8.716-161.0	MDL7-1/2	250V	7.5

**CAM SWITCHES - 3-POSITION - MACHINE CONTROL**

- Heavy-Duty Rotary Cam Switches
- Legend plate reads off / pump / burner
- Quick make / break action reduces arcing
- Wiring Boot Included (Except 410242-3)
- Legend Plate, 2/1/2" Square
- 4-Screw Mounting



PART NO.	MODEL	AMP RATING	VOLTAGE	PHASE
8.712-219.0*	S220-1686	20	110V	1
8.712-224.0*	S220-1687	20	220V	1
8.712-225.0*	S220-1688	20	220V	3
8.712-227.0*	S225-1686	30	110V	1
8.712-228.0*	S225-1687	30	220V	1
8.712-229.0*	S225-1688	30	220V	3
8.712-234.0	S432-4095	40	240V	1
8.712-235.0	S432-1402	40	480V	3
<b>SINGLE-HOLE MOUNTING - REQUIRES 1 22MM (7/8" DIA) HOLE</b>				
8.712-218.0	220-1789	20	110V	1
<b>*REPLACEMENT KNOB - FITS THOSE PART NUMBERS ABOVE MARKED WITH AN ASTERISK (*)</b>				
8.700-258.0	Replacement Knob			

**CAM SWITCHES WITH & WITHOUT BOX**

Cam action fast "make-break" to reduce arcing.

- 40 - 60 Amp disconnect rating
- Four 1/2" Knock-Outs
- Versatile Mounting
- Motor Ratings:  
7.5 HP at 240V, Single Phase  
5.0 HP at 240V, 3 Phase  
30.0 HP at 480V, 3 Phase



PART NO.	DESCRIPTION
8.712-217.0	40 Amp Switch with Large Box 4-1/2" W x 7" H x 3-3/4" D
8.712-211.0	60A/600V, 4P, Salzer Switch Only, No Knob
8.712-212.0	Box Only 3-7/8" x 4-7/8" x 2-3/4" for 8.712-211.0, 60A Salzer Switch Using 10 Gage / Smaller Wire
8.700-489.0	Knob

Note: Switch does not have thermal overload protection

**CAM SWITCHES - 3-POSITION -SALZAR "BIG BOOT"**

Large rectangular boot for easier wiring.

- Mounting configuration and electrical ratings same as "S" switches



PART NO.	MODEL	AMP RATING	VOLTAGE	PHASE
8.712-238.0	T225-1686	30	110V	1Ø
8.712-241.0	T225-1688	30	240V	3Ø
<b>SINGLE-HOLE MOUNTING - REQUIRES ONE 22 MM (7/8" DIA) HOLE</b>				
8.712-223.0	220-1843	20	220V	1Ø

## CAM SWITCHES - 3-POSITION - "ELEKTRA" UNIVERSAL

UL/CSA-rated machine control cam switches.

- Position "off" - "pump burner"
- Quick make / break action - reduces arcing
- 2 or 4 Screw Mount (2-1/2" Square Legend Plate)
- Matches Salzer / Kraus, Naimer / Bremas & Klockner, Moeller Mounts
- "Boot" has plenty of wiring room
- "Tite Boot" excellent dust and moisture seal
- Screw-to-screw, terminal-to-terminal replacement for Salzer "S" and "J" type switches above
- Contacts UL / CSA Rated: 24 Amp vs 20 Amp, 35 Amp vs 30 Amp, 50 Amp vs 40 Amp



8.712-236.0



8.712-237.0



8.712-240.0

PART NO.	AMP RATING	WIRING POLES	VOLTAGE	PHASE	HP RATING
8.712-236.0	25	1	120V	1	1.5
8.712-237.0	25	2	120V / 240V	1	1.5 / 2.0
8.712-240.0	35	2	120V / 240V	1	2.0 / 3.0
8.712-242.0	50	2	120V / 240V	1	3.0 / 7.5

Note: None of the Elektra switches are for use on 3-phase motors without adding fuses or thermal overload

## CAM SWITCHES - ON / OFF WITH BOX - "ELEKTRA"

UL/CSA-rated 25 and 35 Amp. Compact 3-1/4" square x 3-3/4" deep enclosure "versatile mount."



PART NO.	AMP RATING	WIRING POLES	VOLTAGE	PHASE	HP RATING
8.712-214.0	25	2	120V / 240V	1	1.5 / 2.0
8.712-216.0	35	2	120V / 240V	1	2.0 / 3.0

Note: None of the Elektra switches are for use on 3-phase motors without adding fuses or thermal overload

## ROCKER SWITCHES

2500 Watt, 120V, 21.6 Amp at 3,600 RPM

- On / Off, 2 & 3 Position
- Lighted Available
- 125V / 250V / 24V



9.802-453.0



8.716-051.0



9.802-451.0



9.802-452.0

PART NO.	DESCRIPTION	AMP	VOLTAGE
9.802-453.0	Curvette, SPST, 2-Pos, Carling	16 / 10	120V / 250V
8.716-051.0	Curvette, DPST, 2-Pos, Carling	20 / 15	125V / 250V
9.802-451.0	Carling, Green Light, 2-Pos	15 / 10	125V / 250V
9.802-452.0	Green Lamp, Red Actuator, 3-Pos	15 / 10	125V / 250V
8.716-037.0	Rocker Switch	15 / 10	125V / 250V / 24V

Specifications, product descriptions, product availability, and pricing subject to change without notice.



**GENERATOR - WINCO- AC- TB2400**

2400 Watt, 120 VT, 3600 RPM, 20 Amps.



- 13.3" L x 7.6" W x 8.1" H
- 33 lbs.
- Starts and Runs 1/2 HP Motor
- 7/8" diameter shaft
- Conforms to UL1004-1, UL1004-4 and CSA 22.2 No. 100-24

PART NO.	DESCRIPTION
8.757-639.0	TB2400 Generator

**THERMOSTAT - PROBE STYLE**

With panel-mount controls



- PSI: 4000
- Temperature change response within + 12°F
- Accuracy + 2.5%
- 120VAC-20A
- 240VAC-20A
- 120/240VAC-1/4HP
- Large, Easy-Read Dial
- 3-1/2" SS Capillary Copper Immersion bulb with 60" capillary tube. UL/CSA Approved
- Seal, nut and 1/2" transition coupling included

PART NO.	DESCRIPTION
8.758-149.0	86-302 Deg
8.758-180.0	86-195 Deg
8.758-181.0	86-250 Deg

**THERMOSTAT - ADJUSTABLE - FLOW-THRU**



- PSI: 3000
- Adjustable Temperature: 85° - 195°F
- AMP: 10, 110V
- AMP: 5, 220V
- 1/2" Inlet, 3/8" Outlet
- Fenwall Inside
- 8.904-555.0
- Tension Adjusting Screw
- Stop Collar
- Ceramic Insulation
- Silver Contacts
- Stainless-Steel Case
- 8.700-501.0

PART NO.	DESCRIPTION
8.904-555.0	Thermostat
8.700-501.0	Switch Only

**GENERATOR - VOLTMASTER**

2500 Watt, 120V, 21.6 Amp at 3,600 RPM



- 36.5 lbs.
- Brushless Design
- Circuit breaker protection (standard)
- 7/8" Shaft, Two Sealed (Ball) Bearings
- Shaft rotates either direction
- Industrial-Type Watertight Enclosure (11-5/8" x 7-1/2" Diameter)
- All Copper Windings, High Surge Capacity

PART NO.	DESCRIPTION
8.709-810.0	2500 Watt Generator

**DIGITAL POWER MONITOR**

Provides accurate testing and monitoring of electrical outlets and systems.



- Operating Temp: +32°F to +125°F
- Outlet: 120V/15A Single Phase
- Voltage Range: 85 - 150 Vac RMS
- Constantly monitors voltage and frequency indicated potential improper polarity and ground wiring
- Accurate testing and monitoring of all AC power sources
- RMS Voltage and Frequency Meter
- Multi-tone Fault Alarm
- Hands-Free Auto Reset
- Advanced Microelectronics
- One-Button Operation

PART NO.	DESCRIPTION
8.749-947.0	Digital Monitor

**CAM SWITCHES - 2-POSITION**



- Legend Plate: On / Off
- Tear-Drop-Shaped Knob
- Face Plate 2-1/2" Square
- Motor Ratings: 410202 - 1-1/2 HP / 110V 410204 - 6 HP / 240V

PART NO.	DESCRIPTION
8.712-213.0	25 Amp / 110V
8.712-215.0	30 Amp / 220V



## INDICATOR LIGHTS



8.716-408.0    9.802-456.0

- Easy Mounts to Control Panel
- Available in 12V, 24V and 125V
- Great for remote applications

PART NO.	VOLTAGE	COLOR
8.716-095.0	125V	Red
9.802-455.0	125V	Green
8.716-408.0	125V	Amber
9.803-651.0	28V	Red
9.803-652.0	28V	Green
8.716-097.0	12V	Red
9.802-456.0	12V	Green

## BREAKER SWITCHES



PART NO.	DESCRIPTION	PHASE
8.716-067.0	7.5 HP, 230V, 1400	1PH
8.716-068.0	7.5 HP, 230V, 1400	3PH
8.716-069.0	7.5 HP, 460V, 1400	3PH
8.716-073.0	10A / 460V, 900	3PH
8.716-074.0	12A / 480V	3PH
8.716-075.0	15A / 18.8V, 800	3PH
8.716-076.0	20A / 277V, 900	3PH
8.716-070.0	25A / 250V, 2255	3PH
8.716-077.0	30A / 277V, 900	1PH
8.716-066.0	40A / 230V, 1070	1PH

## WIRE LOOMS - USED FOR WIRING HARNESES



- Protects wires from abrasion and crushing
- Controls bundles of wires and allows for multiple exits at wiring points
- "Factory-perfect" look for all machines

PART NO.	DESCRIPTION
8.709-679.0	1/4" ID 100' Roll
8.709-680.0	3/8" ID 100' Roll
8.709-681.0	1/2" ID 100' Roll
8.709-682.0	5/8" ID 100' Roll

## GFCI MODULE

Not recommended for field service.



- AMP: 20 at 120V or 240V, 60 Hz
- Using 120V or 240V shop attachable module; attach your power cord length as required
- Use with 16-12 gauge SJ, SJO or SJT, 3-wire cords

PART NO.	DESCRIPTION	PHASE
8.709-858.0	GFCI Module	1PH

## TAPE - VINYL ELECTRICAL



- Premium Grade, 7 mil
- UL-Approved

PART NO.	DESCRIPTION
8.704-706.0	Roll 3/4" x 60'

## CONNECTOR CLAMPS - ROMEX (METAL)



PART NO.	DESCRIPTION
8.709-663.0	1/2" Strt. Connector
8.709-664.0	3/4" Strt. Connector
8.709-660.0	1/2" Lock Nut Only
8.709-661.0	3/4" Lock Nut Only

## CORD CAPS & PLUGS



- |  |                           |                           |  |
|--|---------------------------|---------------------------|--|
| <p><b>8.709-653.0</b></p> <ul style="list-style-type: none"> <li>■ Industrial-Quality</li> <li>■ Dead front cord caps - nylon body straight plugs and "auto-clamp" for cord</li> </ul> | <p><b>8.709-655.0</b></p> | <p><b>8.709-656.0</b></p> | <p><b>8.709-659.0</b></p> <ul style="list-style-type: none"> <li>■ 8.709-659.0 angle plug has vinyl body and both 30A and 50A neutral leg</li> </ul> |
|--|---------------------------|---------------------------|--|

PART NO.	DESCRIPTION	MATERIAL
8.709-653.0	15A / 125V	Black Nylon
8.709-655.0	20A / 125V	Black Nylon
8.709-656.0	20A / 220V	Black Nylon
8.753-905.0	30A-50A / 250V	Black Vinyl

## CONNECTOR / STRAIN RELIEFS - LIQUID TIGHT - FOR CABLE, WIRE & TUBING

Keep water-tight NEMA-4 and 4x enclosures water-tight with these unique fittings.

### DOME NUT WITH INSIDE TAPER

- As the dome nut is tightened, the seal ring grips, holding the cable wire or tubing positively in place.

### LEAD-SCREW THREAD

- The dome nut can be firmly tightened due to the high strength lead-screw thread.

### CLAMPING SPLINES

- Various sizes and odd-shaped cables, wires and tubing can be accommodated due to overlapping diagonally split clamping splines



PART NO.	TYPE	THREAD	CORD SIZE	CORD OD	LENGTH
9.802-514.0	Dome	1/2" NPT	14/3-12/3	.230" - .470"	1.8"
8.709-688.0	Dome	3/4" NPT	14/3-12/3	.350" - .630"	2.0"
8.709-689.0	Dome	3/4" NPT	12/3-10/4	.510" - .710"	2.0"
8.709-690.0	Flex	1/2" NPT	14/3-12/3	.230" - .470"	4.3"
8.709-692.0	Flex	3/4" NPT	12/3-10/4	.51" - .71"	5.2"



PART NO.	THREAD
<b>PLASTIC JAM NUTS</b>	
9.802-525.0	1/2" NPT
9.802-526.0	3/4" NPT

## GFCI - WITH AND WITHOUT PLUGS & CORDS

GFCIs protect people and equipment by interrupting potentially lethal ground circuits exceeding 6mA. The dangers of electrical shocks have been long known - GFCIs are the only real way to be safe. Most city and county codes now require GFCI protection on power cleaning equipment.

- UL-Listed
- Three Wire Circuits
- Transient Voltage Protection
- 4-6mA Ground Fault Protection
- Grounded Neutral Protection
- Mechanical Trip Indicator
- Compact Size
- Rugged Construction
- Radio Frequency Interference Suppression



Integrated GFI & Plug



PART NO.	VOLTAGE	AMP	LENGTH	INTEGRATED
<b>GFCI CORD WITHOUT PLUG</b>				
8.709-842.0	120V	20A	12'	N/A
8.709-860.0	240V	30A	6'	N/A
8.709-861.0	240V	30A	12'	N/A
8.709-862.0	240V	30A	35'	N/A
9.802-434.0	240V	40A	36'	N/A
<b>GFCI CORD WITH PLUG</b>				
8.709-850.0*	120V	15A	12'	Combo
9.802-432.0*	120V	15A	36'	Combo
8.709-843.0	120V	20A	37'	Separated
9.802-431.0*	120V	20A	36'	Combo
9.802-433.0	240V	20A	36'	Separated
8.709-853.0	240V	30A	6'	Separated
8.709-854.0	240V	30A	12'	Separated
8.709-855.0	240V	30A	35'	Separated
9.802-430.0	240V	30A	36'	Separated
<b>GFCI PLUG WITHOUT CORD</b>				
8.709-847.0	120V	15A	N/A	N/A
8.709-846.0	120V	20A	N/A	N/A

Note: User-attached plug also includes the sealant necessary to attach the power cord per UL specification  
 \* Integrated GFI & Plug



## MOLDED PLASTIC FLOAT TANKS



- Molded Polypropylene
- 7 Liter Size: 13" x 5" x 6"
- 1 Gallon Size: 10" x 5" x 8"
- No Holes for Max Flexibility
- 1-Gallon Tank has Tight Fitting Lid (included)
- 7-Liter Snap-on Tank Lid (sold separately)

PART NO.	DESCRIPTION
8.710-026.0	7-Liter Tank Only
8.710-027.0	7-Liter Tank Lid
8.710-028.0	1-Gallon Tank with Lid

## STAINLESS-STEEL FLOAT TANK



- Fully Welded and Water Tight
- 2.8 Gallon Capacity
- 12" x 9" x 6"
- 16 Gauge #303 Stainless-Steel
- 1/2" Full Coupling, Stainless-Steel Inlet / Outlet
- Convenient Mounting Tabs

PART NO.	DESCRIPTION
8.710-029.0	Stainless-Steel Float Tank
8.710-034.0	Stainless-Steel Lid

## FRAMES, DIRECT DRIVE



- Heavy-duty Aluminium, More Corrosion-resistant than Steel
- 10" Flat-free Tire for Better Reliability
- Integrated Nozzle Holders

PART NO.	DESCRIPTION
8.924-399.0	Aluminium Frame, DD CW
8.924-400.0	Aluminium Frame, 270 and 390 AL DD CW

## REPLACEMENT FUEL CAP

- Fits 9 Gallon Diesel Fuel Tank (8.710-142.0)
- Fits Fuel Tanks (8.751-294.0, 8.751-296.0, 8.751-293.0)

PART NO.	DESCRIPTION
8.751-449.0	Replacement Fuel Cap for Fuel Tanks

## FUEL TANK, 9-GALLON DIESEL



- Strap or Bolt Mount (4 / 5/ 16" Inserts in Bottom)
- Metal Inset 3/8" Inlet / Return Lines
- Black, Crosslinked PE
- Vented Fuel Cap
- Filler Neck Doesn't Extend Beyond Tank Wall
- Compact Size: 19-3/4"L x 12"W x 10-1/2"H

PART NO.	DESCRIPTION
8.710-142.0	9-Gallon Fuel Tank - Plastic

Note: Includes Fuel Cap

## FUEL TANKS



8.751-293.0

- EPA / CARB-Compliant
- Seamless One-piece Construction of Marine Grade, UV-protected Polyethylene
- 90° Fuel Withdrawal Fitting



8.751-294.0

- Two-stage Click when Closed Fuel Cap
- Built-in Reserve (when gauge reads "empty", tilt to access additional fuel)
- Easy-to-read Sight Gauge

PART NO.	SIZE	DIMENSIONS (LxWxH)
8.751-294.0	6-gal	21.18" x 13.5" x 10"
8.751-296.0	12-gal	20.375" x 13.75" x 14.75"
8.751-293.0	12-gal	24.25" x 18" x 11"

### RUBBER PARTS



PART NO.	DESCRIPTION
9.802-064.0	Grommet, Nozzle Holder
8.706-557.0	Bellows, Leg Boot
9.802-067.0	Bumper Pad, Engine
9.802-069.0	Handle Grip
8.706-745.0	Plug, Hole Plastic
9.803-046.0	Mount, Rubber Vibration
8.706-553.0	Mount, Rubber Vibration 60 Duro
8.706-524.0	Mount, Rubber Vibration 1-3/8" Dia x 3/4"
9.802-066.0	Pad, Soft Rubber

### FUEL CAPS



- For Gas or Diesel Fuel Tanks
- Fits Standard 2-1/4" Fuel Necks

PART NO.	DESCRIPTION
8.701-700.0	Fuel Cap with Gauge 10"

### BATTERY BOXES WITH COVER, MARINE STYLE

Protect batteries on pressure washers, boats or other industrial equipment.



- Attractive Molded Polypropylene
- Complete with hold-down cleats and strap for cover
- Small: 8-1/2"L x 6"W x 8-1/2"H
- Large: 11-1/4"L x 7-3/4"W x 10-3/4"H

PART NO.	DESCRIPTION
8.706-652.0	Small Box
8.706-600.0	Large Box

### FLAT-FREE TIRES

Flat-free tires provide the bounce and load handling characteristics similar to an air filled tire - with the benefit of never going flat. Flat-free tires are lightweight, non-marking and come mounted on a heavy-duty steel rim with shielded ball bearings. Not for highway use.



- Heavy-Duty Steel Rim
- Non-Marking
- 4" Steel Rim: Max Load 300 lbs.
- 12" Steel Rim: Max Load 375 lbs.
- Accepts .63" Shaft

PART NO.	DESCRIPTION
8.711-898.0	 Wheel and Tire Assembly, 4" Steel Rim
8.758-460.0	Wheel and PU Tire Assembly, 12" Steel Rim

### PLASTIC DIP TUBE ASSEMBLY



- Rubber bushing seal (order separately)
- New Style Plastic Dip Tubes

PART NO.	DESCRIPTION
8.706-494.0	Plastic Dip Tube Assembly, 7.5" Long
8.706-495.0	Plastic Dip Tube Assembly, 12" Long
8.706-496.0	Plastic Dip Tube Assembly, 17.75" Long
9.802-053.0	Rubber Bushing, Fuel Line

**COMPLETE WHEELS**



**8.711-901.0**      **8.754-186.0**      **8.758-460.0**      **8.712-762.0**

- High-Quality Pneumatic and Semi Pneumatic
- Fits 5/8" Shaft

PART NO.	DESCRIPTION
8.711-901.0	10" Mag
8.754-186.0	10" Steel Rim with Tube
8.758-460.0	12" Steel Rim
8.712-762.0	10" White Steel Rim, 3/4" Hub Tubeless
8.711-905.0	6" Steel Rim Foam Filled
8.711-921.0	6" Tube Only
8.712-767.0	10" Tube Only
9.802-274.0 	10" x 2-3/4" Hard Rubber Wheel
8.711-908.0	3" Gray Caster Wheel
INTERCHANGEABLE BEARINGS	
8.700-484.0	5/8" Bore Bearing
8.700-486.0	3/4" Bore Bearing
8.700-485.0	5/8" Nylon Bearing
HUB CAPS AND COLLARS	
8.700-183.0	3/4" Hub Cap
8.700-184.0	5/8" Hub Cap
9.802-782.0	5/8" Bore Shaft Collar



**8.700-486.0**



**8.700-485.0**

**MISCELLANEOUS PARTS**



**8.719-064.0**      **9.802-066.0**      **8.932-992.0**

PART NO.	DESCRIPTION
8.719-064.0	Chassis Knob 5/16" Thread, Black
9.802-066.0	Soft Rubber Foot Pad
8.932-992.0	Vibration Isolator 3/8"



**PUMP - AIR-OPERATED - FLOJET**



- Twin Diaphragm, Self-priming
- Dry Air (or CO2) PSI: 20-120
- GPM: 7.0
- Max Liquid Temperature: 120°F
- Santoprene Elastomers
- Self-Priming up to 15 Feet
- Air (Gas) In & Out, 1/4" Barb
- Choice of 3/8" or 1/2" Barb Fluid In/Out
- Automatic, On-Demand Start & Stop
- Flow Control via Air (Gas) Pressure
- Common Use: Chemical transfer and dispensing parts, washers and car wash systems

PART NO.	DESCRIPTION
8.702-321.0	3/8" Pump, Santoprene
8.702-322.0	3/8" Pump, Viton
8.702-323.0	1/2" Pump, Santoprene
8.702-324.0	1/2" Pump, Viton

**PUMPS - AIR-DRIVEN - FLOJET FLOJET**

Twin diaphragm, self-priming.



- Dry Air (or CO2) PSI: 20-80
- GPM: 1.9
- Max Liquid Temperature: 120°F
- Santoprene/Viton Elastomers: Use Santoprene for Soaps, Use Viton for Butyls
- Chemical In & Out, 3/8" Barb
- Air (Gas) In & Out, 1/4" Barb
- Automatic, On-demand Start & Stop
- Control Flow and Pressure with Air Pressure

PART NO.	DESCRIPTION
8.702-320.0	Pump, Santoprene
8.702-319.0	Pump, Viton
8.700-388.0	Valve Kit, Santoprene

**AIR-FILTER / REGULATORS**



8.712-585.0



8.712-586.0

- PSI: 125
- 1/4" Ports
- Pressure-Relieving
- Removes air line impurities to 5 microns
- Maintains and gauges pressure to, and therefore discharges pressure from, air-driven diaphragm pumps

PART NO.	DESCRIPTION
8.712-585.0	Regulator Only
8.712-586.0	Filter / Regulator
8.712-587.0	Gauge, 0-1 60, 1/8"

**BRUSHES - FOAM & ACCESSORIES**



**FOAM BRUSH**

- 3" x 10" super soft flagged bristle fountain brush. Choose from black, red or blue.



**FOAM BRUSH LANCE**

- 40" long with 30" insulated grip, 3/8" FPT inlet, 1/2" MPT outlet (matches brush inlet). Colors: red, blue or black.



**BRUSH HOSES**

- Clear, spiral wire braid, 1/2" ID with 3/8" MPT, zinc-plated steel fittings both ends.

PART NO.	DESCRIPTION
8.710-115.0	Foam Brush Head, Black
8.710-117.0	Foam Brush Head, Red
8.710-116.0	Foam Brush Head, Blue
8.710-119.0	Foam Hose, 15'
8.710-121.0	Lance 40", Red
8.710-122.0	Lance 40", Black
8.710-123.0	Lance 40", Blue

## CAR WASH BOOMS, "REFLEX"

The performance leader!



- PSI: 3000
- 5' 6" Car Wash Model
- 8' Truck Wash Model
- Stainless-Steel Boom Arm
- 3/8" FPT Inlet / Outlet Hose (Included)

PART NO.	DESCRIPTION
<b>BOOMS</b>	
8.903-620.0	180° Wall Mount 5' 6" Boom
8.903-621.0	360° Ceiling Mount 5' 6" Boom
8.903-624.0	180° Wall Mount 10' Boom
8.903-625.0	360° Ceiling Mount 10' Boom
8.903-626.0	180° Wall Mount 8' Boom
8.903-627.0	360° Ceiling Mount 8' Boom
<b>PARTS / ACCESSORIES</b>	
8.903-622.0	5.5' Rod / Hose, Assy Only
8.903-623.0	8' Rod / Hose, Assy Only
8.903-628.0	10' Rod / Hose, Assy Only
8.903-630.0	Ceiling Mount, Base Only
8.903-632.0	Wall Mount, Base Only
8.700-265.0	Set Screw for Angle Block
8.905-605.0	90° End Coupler C/W Boom
8.905-604.0	8' Coupler Stainless-steel C/W Boom
8.712-450.0	Swivel - Brass 3/8"
8.700-263.0	Swivel Repair Kit (Pre-1998)
8.700-287.0	Swivel Repair Kit (1998-Present)

## WASH BAY ACCESSORIES - STAINLESS-STEEL

Foam brush broom holder, wand holders, mat clamps.



PART NO.	DESCRIPTION
8.708-880.0	Standard Foam Brush Holder
	Rigid Wall Mount Wand Holder
8.708-882.0	Flex Bottom Mount Wand Holder
8.708-883.0	Mat Clamp

## LOCKS FOR METER BOXES



PART NO.	DESCRIPTION
8.708-730.0	Tubular Cam Lock

## SWITCH - ROTARY - 8-POSITION

Metal car wash switch.



- Double Stack 8-Position
- Metal
- Much more durable than cheaper plastic switches
- Direct replacement for Electroswitch 31302A-S and NU32LA
- Make before break functions

PART NO.	DESCRIPTION
8.708-729.0	8-Position Rotary Switch

## TRANSFORMERS



PART NO.	DESCRIPTION
8.708-780.0	115-24V AC: 600 MIL/AMP
8.708-781.0	115/208/230-24V AC: 100V A Fused
8.708-783.0	120/208/240-24V AC: 50V A
8.708-784.0	120/208/240-24V A Not Fused

## FUSES



PART NO.	DESCRIPTION
8.708-786.0	Transformer Fuse 5 AMP

### SWIVELS - MEDIUM-PRESSURE - CAR WASH



- PSI: 1000
- 7/16" Flow-Thru Opening
- All-Brass Body
- Bronze-Thrust Bearing
- Buna Seals (Non-Repairable)
- 1/2" FPT x 1/2" MPT

PART NO.	DESCRIPTION
8.705-057.0	Swivel

### SWIVELS - LOW-PRESSURE - CAR WASH



- Swivel Action PSI: 300
- Brass MPT
- Zinc-Chromate Steel FPT

PART NO.	DESCRIPTION
8.705-054.0	1/4" FPT x 1/4" MPT
8.705-056.0	3/8" FPT x 3/8" MPT
8.705-055.0	1/2" FPT x 1/2" MPT

### LANCES - FLEX



- PSI: 2500
- Temperature: 200°F
- Flexes 180° and returns
- Prevents bent lances and broken hoses
- Industrial-grade polyurethane flex section
- Perfect for self-serve car wash bays
- 1/4" galvanized pipe end sections

PART NO.	LENGTH	DESCRIPTION
8.710-600.0	18"	1/4"MPT x 1/8"FPT, Black
8.710-601.0	18"	1/4"MPT x 1/8"FPT, Blue
8.710-603.0	21"	1/4"MPT x 1/8"FPT, Red
8.710-604.0	24"	1/4"MPT x 1/8"FPT, Red
8.710-598.0	18"	1/4"MPT x 1/4"MPT, Red

### VACUUM ACCESSORIES

May slip directly on to hose. Use with swivel cuffs for better results.



#### Vacuum Claw Nozzle

PART NO.	COLOR
<b>1-1/2"</b>	
8.708-892.0	Yellow
8.708-891.0	Black
8.708-890.0	Gray
<b>2"</b>	
8.708-894.0	Yellow



#### Adapter

PART NO.	DESCRIPTION
8.708-900.0	2" Hose x 1-1/2" Wand
8.708-904.0	2" Hose x 2" Wand



#### Cuffs, Hose to Tank

PART NO.	DESCRIPTION
8.708-903.0	1-1/2" x 1-1/2"
8.708-904.0	2" x 2"
8.708-905.0	1-1/2" x 1-1/2" Swivel

#### Vacuum Hose

PART NO.	DESCRIPTION
8.697-112.0	50' Blue Vac hose 1-1/2" Swivel
8.697-117.0	50' Blue Vac hose, 2" Swivel

### TRIGGER GUN - RB65 WASH GUN

Low-pressure spray gun with straight jet and adjustable cone from the trigger with adjustable screws to alter cone angle wideness from 0° to 60°.



- PSI: 350
- GPM: 16.0
- Temperature: 195°F
- Completely Sealed
- Ergonomic
- Adjustable Jet Cone
- Trigger Protection
- Brass Body
- Inlet Connection Swivel

PART NO.	DESCRIPTION
8.710-449.0	PA RB65 with Swivel
8.710-448.0	PA RB65 No Swivel
9.114-478.0	PA RB65 Stainless Steel w/ Swivel (RED)

**VACUUM MOTORS - A+ / AP**



8.625-841.0



8.620-204.0



8.625-842.0

PART NO.	DESCRIPTION
<b>TWO FAN STAGES, BYPASS MOTORS</b>	
8.625-841.0	5.7" Diameter, 120V Double Ball Bearing, Peripheral Discharge
8.620-204.0	Vault System Vac Motor: 120V Double Ball Bearings, Tangent Discharge
<b>THREE FAN STAGES, BYPASS MOTORS</b>	
8.625-842.0	5.7" Diameter, 120V Double Ball Bearings, Tangent Discharge

**VACUUM MOTORS - AMETEK-LAMB**



8.685-502.0



8.685-442.0



8.685-458.0

PART NO.	DESCRIPTION
<b>TWO FAN STAGES, BYPASS MOTORS</b>	
8.685-502.0	5.7" Diameter, 120V Double Ball Bearing, Peripheral Discharge
8.685-442.0	Vault System Vac Motor: 120V Double Ball Bearings, Tangent Discharge
<b>THREE FAN STAGES, BYPASS MOTORS</b>	
8.685-458.0	5.7" Diameter, 120V Double Ball Bearings, Tangent Discharge

**HOSES - CONNECTOR / CAR WASH BAY, 12'-25'**

All car wash bay hoses come with solid male pipe on both ends.



PART NO.	LENGTH	PSI
<b>3/8" BLACK - 1 WIRE</b>		
8.918-333.0	12'	4000
8.918-334.0	13'	4000
8.918-338.0	15'	4000
8.918-340.0	16'	4000
8.918-342.0	17'	4000
8.918-344.0	18'	4000
8.918-348.0	20'	4000
<b>3/8" BLUE - 1 WIRE</b>		
8.918-360.0	12'	3000
8.918-362.0	13'	3000
8.918-366.0	15'	3000
8.919-124.0	16'	3000
8.918-369.0	17'	3000
8.918-371.0	18'	3000
8.918-373.0	19'	3000
8.918-375.0	20'	3000
8.918-385.0	25'	3000
<b>1/4"BLUE - 1 WIRE</b>		
8.918-387.0	12'	3000
8.918-389.0	13'	3000
8.918-391.0	14'	3000
8.918-393.0	15'	3000
8.918-395.0	16'	3000
8.918-397.0	17'	3000
8.918-399.0	18'	3000
8.918-401.0	19'	3000
8.918-403.0	20'	3000
8.918-409.0	23'	3000
8.918-411.0	24'	3000
8.918-413.0	25'	3000

**SOLENOID VALVES - CFA - SS & BRASS**



- Air
- Professional Car Washes
- Low Pressure Steam
- Light Oil
- Chemicals
- Other Industrial Applications

**WATER SOLENOID VALVES 2-WAY, NORMALLY CLOSED.**



The S211 Series Standard Water Valves have reliable piloted diaphragm construction with proven performance over decades of use. Featuring stainless-steel seats, the S211 Series typically requires 4 or 5 PSI pressure differential to open. The S201 Series Zero Differential Valves are constructed with the

same materials, but are capable of operating with the same amount of pressure on both sides of the valve. Both valve types are often utilized in the car wash industry.

**HIGH-PRESSURE SOLENOID VALVES 2-WAY, NORMALLY CLOSED.**



The S401 High-Pressure Valves are compact, dependable and specifically designed by ITT to meet car wash applications up to 1400 PSI. Best Buy.

**CHEMICAL SOLENOID VALVES, 2-WAY, NORMALLY CLOSED.**



For decades, car wash industry professionals have chosen the rugged S301 and S311 Series Valves because of their compact size and long life. Available in 1/8", 1/4" and 3/8" NPT designs, these valves are used in air, water and chemical applications.

**SOLENOID VALVES FOR CAR WASH ANTI-FREEZE APPLICATIONS, NORMALLY OPEN**

These valves provide long life and reliable performance in the "make or break" anti-freeze systems of car washes. The S202 and S212 Series Diaphragm Valves feature non-wicking, fabric-reinforced diaphragms, which eliminates premature diaphragm failures, as well as stainless-steel upper seats, which prevents seat deterioration often associated with brass-seated valves. The S202 Series Diaphragm Valve incorporates the zero-operating pressure design discussed above; the S212 Series is a piloted diaphragm, and the S402 Series is piloted piston valve.

**SOLENOID VALVES - CFA - SS & BRASS**



<b>BODY</b>	<b>SEALS</b>	<b>MODE</b>	<b>TYPE</b>	
BR = Brass	B = Buna	N/O = Normally Open	DA = Direct Acting	PP = Piloted Piston
SS = Stainless-Steel	V = Viton	N/C = Normally Closed	PD = Piloted Diaphragm	

PART NO.	GC PART NO.	PORT F-NPT / BODY	ORIFICE	OPER PSI	SEALS	MODE	TYPE / AC VOLTS	DEMA EQUIV
8.708-806.0	S201-CG4	3/8" / BR	.312"	150	B	N/C	PD / 110	A413P-110
8.708-807.0	S201-DG4	1/2" / BR	.438"	150	B	N/C	PD / 24	A414P-24
8.708-808.0	S201-DG4	1/2" / BR	.438"	150	B	N/C	PD / 110	A414P-110
8.708-821.0	S211-CG4	3/8" / BR	.625"	150	B	N/C	PD / 110	473P-110
8.708-822.0	S211-DG4	1/2" / BR	.625"	150	B	N/C	PD / 24	474P-24
8.708-823.0	S211-DG4	1/2" / BR	.625"	150	B	N/C	PD / 110	474P-110
8.708-824.0	S211-EG5	3/4" / BR	.750"	150	B	N/C	PD / 24	476P-24
8.708-825.0	S211-EG5	3/4" / BR	.750"	150	B	N/C	PD / 110	476P-110
8.708-826.0	S211-FG9	1" / BR	1.00"	150	B	N/C	PD / 24	-
8.708-827.0	S211-FG9	1" / BR	1.00"	150	B	N/C	PD / 110	-
8.708-829.0	S301-BD7	1/4" / BR	.109"	150	B	N/C	DA / 24	401P-24
8.708-830.0	S301-BD7	1/4" / BR	.109"	150	B	N/C	DA / 110	401P-110
8.708-816.0	S202-DG4	1/2" / BR	.438"	150	B	N/O	PD / 24	0A414P-24
8.708-831.0	S301-BD7	1/4" / SS	.125"	150	V	N/C	DA / 24	424-2-24
8.708-832.0	S301-BD7	1/4" / SS	.125"	150	V	N/C	DA / 110	424-2-110
8.708-833.0	S401-Z	3/8" / SS	.350"	1200	V	N/C	PP / 24	453P-24
8.708-834.0	S401-Z	3/8" / SS	.350"	1200	V	N/C	PP / 110	453P-110
8.708-835.0	S401-Z	1/2" / SS	.500"	1200	V	N/C	PP / 24	454P-24
8.708-836.0	S401-Z	1/2" / SS	.500"	1200	V	N/C	PP / 110	454P-110

**REPLACEMENT / REPAIR KITS FOR SOLENOID VALVES**

8.708-837.0	24V AC Coil
8.700-217.0	Repair Kit - S301, 1/4" Valves (Viton)
8.700-220.0	Repair Kit - S211, 3/4" Valves (Buna)

## SOLENOID VALVES - KIP - SS & BRASS

■ Reliable over years of use

■ Millions of cycles life not unusual

■ All with FPT Ports



8.708-846.0



8.708-849.0



8.708-863.0

**MODE**

N/O = Normally Open

N/C = Normally Closed

**TYPE**

N/A = Not Adjustable

C/A = Chemical Adjustment

PART NO.	MODE	FPT	VOLTAGE	TYPE	ORIFICE ID
<b>STAINLESS-STEEL</b>					
8.708-846.0**	N/C	1/4"	24V AC	N/A	.062
8.708-849.0	N/C	1/8"	24V AC	N/A	.062
8.708-851.0	N/C	1/4"	24V AC	C/A	
8.708-852.0*	N/C	1/4"	24V AC	C/A	
8.708-855.0	N/C	1/4"	120V AC	N/A	.093
8.708-856.0	N/C	1/4"	24V AC	N/A	.093
8.708-857.0*	N/C	1/4"	120V AC	N/A	.093
8.708-858.0*	N/C	1/4"	24V AC	N/A	.093
<b>BRASS SOLENOID VALVES - KIP</b>					
8.708-863.0*	N/C	1/8"	240V AC	N/A	.062
8.708-864.0*	N/C	1/8"	120V AC	N/A	.062
<b>PARTS</b>					
8.708-859.0	Coil Only		120V	Wire Leads	
8.708-860.0	Coil Only		24V	Wire Leads	

\*Conduit Body Style with Wire Leads \*\* Wire Leads

## SOLENOID VALVES WITH BUILT-IN STRAINERS

For pressure lines and pressure systems only.

**BRASS VALVES - DIAPHRAGM STYLE**

■ Normally close valve operation

■ Proven design features for reliable performance on all applications

■ Operates in any position, but do NOT mount valve with coil under valve

■ Rated to 200°F fluid and 120°F ambient

**CELCON PLASTIC VALVES - SUPER FOR STRONG CHEMICALS**

■ PSI: 125

■ 1/4" & 3/8" FPT, 1/4" Orifice

■ Molded coil CSA-approved

■ Normally closed operation

■ Temperature: 180°F

■ Diaphragm style with Y-screen (S.S.)

■ Compact design - 1/4" spade connects



PART NO.	DEMA NO.	FPT	ORIFICE	PSI	VOLTAGE
<b>BRASS VALVES - DIAPHRAGM STYLE</b>					
8.711-249.0	442P	1/4"	.25	125	24V AC
8.711-250.0	442P	1/4"	.25	125	110V AC
8.711-252.0	443P	3/8"	.25	125	24V AC
<b>CELCON PLASTIC VALVES</b>					
8.708-869.0	P442	1/4"	.25	125	24V AC
8.708-870.0	P442	1/4"	.25	125	110V AC
8.708-871.0	P442	1/4"	.25	125	12V AC
8.708-872.0	P443	3/8"	.25	125	24V AC



**PROPORTIONER FLOAT VALVE SYSTEMS - AQUA MASTER™ MODEL 440**



Liquid level proportioning controls - automatically maintain drum level and chemical concentration. The Aqua Master automatically maintains a desired level of proportioned mixture in a drum, tank or other type reservoir.



Magnetically activated "snap acting" float valves provide full water flow to activate the chemical proportioners. There are two basic sizes to give a choice of water flows as shown in the table below. Chemical feed rate is adjusted by metering screw or threaded metering tips. The compact 440 float valve is made of Celcon® plastic and is easily accessible for field maintenance.

Liquid-level proportioning controls are available in two flow capacities, 4.0 and 22.0 GPM at 50 PSI. Either size can be used with or without a proportioner. The proportioner allows chemical to be inducted while the valve is open.

All models, except as noted, are equipped with siphon breakers to prevent backflow into the fresh water line. The proportioner discharge is provided with means for attaching a hose or piece for under water feeding to minimize sudsing.

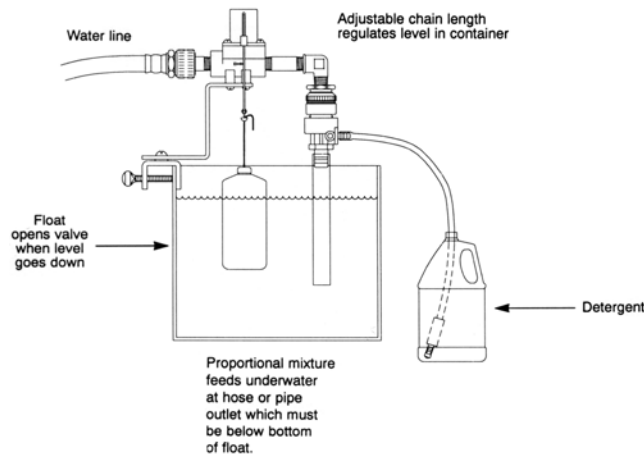

MODEL	DESCRIPTION	CAPACITY
440-23BT	Proportioning Valve, 4 GPM Flow at 50 PSI, Medium Capacity	12*
440-23T	Proportioning Valve, 4 GPM Flow at 50 PSI, High Capacity	35*
440-24	Proportioning Valve, 4 GPM Flow at 50 PSI, Highest Capacity	70*
437-21	Proportioning Valve, 22 GPM Flow at 50 PSI, Medium Capacity	10*

\*Oz. / Gal of 1 CPS Fluid (ie, Viscosity of Water)

PART NO.	DESCRIPTION
8.710-525.0	440-23BT
8.710-524.0	440-23T
8.710-526.0	440-24
8.710-534.0	Optional Tips

**VALVE - 3-WAY - ERIE MOTORTROL®**



- Three-way valve to switch hot and cold inlets to single outlet
- 1/2" MPT (all three)
- 24V AC

PART NO.	DESCRIPTION
8.708-879.0	Motortrol Valve

**PROPORTIONERS & ACCESSORIES - DEMA**

Designed to blend liquid chemical concentrates with water (flowing at normal city water pressure) to create an accurate mix of diluted chemicals. Complete with metering orifice set and/or metering adjustment valve.



- 1 CPS = Viscosity of Water
- 75 CPS = Viscosity of SAE 10 Oil
- 220 CPS = Viscosity of SAE 30 Oil

MODEL NO.	DESCRIPTION	CAPACITY		
Max Blend Rate = Oz. Chem Per Gal Water				
		1 CPS	75 CPS	220 CPS
162		24	14	6
163H*		64	30	14

\*High-concentration chemical blender

PART NO.	DESCRIPTION
8.710-530.0	#162 Drum Mount with Proportioner
8.710-529.0	#163H High Concentrate Proportioner Low Side
8.700-226.0	Polypropylene Foot Valve
8.710-534.0	Optional Tips



## HYPRO ROLLER PUMPS

Ideal for farm sprayers, pest control and chemical application usage.



- Maximum Fluid Temperature: 140°F
- Self-Priming Operation: Roller Pumps Should Not be Run Dry
- Adaptable to PTOs or Gas Engines
- Standard Super Rollers Provide the Chemical Resistance of Nylon and Long Life of Polypropylene
- Rotation is Determined by Looking at Shaft End of Pump



PART NO.	MODEL NO.	HOUSING	ROTATION	SHAFT DIA	NO. OF ROLLERS	SEALS
8.702-281.0	4101C	Cast-Iron	CW	5/8"	4	Viton
8.702-261.0	6500C	Cast-Iron	CCW	5/8"	6	Viton
8.702-263.0	6500C-R	Cast-Iron	CW	5/8"	6	Viton
8.702-282.0	7560C	Cast-Iron	CCW	15/16"	8	Viton
8.702-283.0	7560C-R	Cast-Iron	CW	15/16"	8	Viton

## PERFORMANCE TABLES



### SERIES 4001

- PSI Max: 150
- GPM Max: 9.0
- RPM Max: 1,800

PRESSURE IN PSI	GPM @ 1,100 RPM	HP	GPM @ 1,400 RPM	HP	GPM @ 1,800 RPM	HP
50	4.4	.24	5.9	.32	8.0	.46
100	3.8	.41	5.3	.56	7.3	.78
125	3.5	.50	5.0	.68	7.0	.95
150	3.3	.62	4.8	.78	6.7	1.10

### SERIES 6500

- PSI Max: 300
- GPM Max: 21.8
- RPM Max: 1,200

PRESSURE IN PSI	GPM @ 1,100 RPM	HP	GPM @ 1,400 RPM	HP	GPM @ 1,800 RPM	HP
50	8.0	.38	16.5	.71	20.1	.90
100	7.2	.68	15.4	1.26	19.1	1.51
125	5.6	1.29	14.0	2.34	17.3	2.84
150	4.3	1.91	12.7	3.47	15.7	4.17

### SERIES 4101

- PSI Max: 150
- GPM Max: 7.0
- RPM Max: 2,600

PRESSURE IN PSI	GPM @ 1,100 RPM	HP	GPM @ 1,400 RPM	HP	GPM @ 1,800 RPM	HP
50	4.5	.34	5.60	.40	6.6	.46
100	3.9	.56	5.0	.68	6.0	.76
125	3.7	.68	.82	.82	5.7	.92
150	3.4	.78	4.40	.96	5.4	1.08

### SERIES 7560

- PSI Max: 300
- GPM Max: 22.5
- RPM Max: 1,000

PRESSURE IN PSI	GPM @ 1,100 RPM	HP	GPM @ 1,400 RPM	HP	GPM @ 1,800 RPM	HP
50	11.1	.74	17.5	1.26	22.0	1.78
100	10.3	1.25	16.9	1.95	21.3	2.53
125	8.6	2.26	15.5	3.40	20.0	4.20
150	7.1	3.30	18.9	5.30	18.0	6.10

**FLOJET DIAPHRAGM PUMP**



Built-in pressure switch automatically starts and stops pump instantaneously.



- Can run dry without damage
- Excellent Self-Priming Capability
- Low-Current Draw

PART NO.	FLOJET MODEL NO.	VOLTAGE	GPM	MAX PSI	PORTS	DIAPHRAGM*	VALVES*
8.702-328.0	4300-142A	12V DC	3.50	40	1/2" Barb	S	E
8.702-312.0	2100-032	115V	1.85	50	3/8" FPT	S	S
8.702-337.0	2100-022A	115V	1.85	50	3/8" FPT	V	V
8.702-331.0	4300-042	115V	3.50	45	1/2" Barb	S	E
8.702-329.0	4300-043A	115V	4.70	35	1/2" Barb	S	E

\*V = Viton E = EPDM S = Santoprene

Note: These units are designed to withstand many harsh chemicals. However, because compounds and concentrations of materials pumped through these units are beyond the manufacturer's control, the manufacturer DOES NOT PROVIDE A WARRANTY on the wet-end of the pump.

**DIAPHRAGM PUMP UNITS**



1.0 - 3.8 GPM integrated pump motor units. Powered by 12V DC or 115V AC power. Pumps are standard with Santoprene® diaphragms and Viton valves for excellent service with a wide variety of sprayable products.

NOTE: Flow is reduced as pressure is increased (i.e. 100580 pumps 1.12 GPM at 60 PSI) automatic demand control on/off.



- Chemical-Resistant Materials
- Can run dry without damage
- Self-Priming
- Low-Amp Draw
- Automatic demand pressure switch or interanal bypass

PART NO.	SHURFLO MODEL NO.	POWER	VOLTAGE	GPM	MAX PSI	PORTS	DIAPHRAGM*	VALVES*
8.702-294.0	8000-541-236	Demand	12V DC	1.0	60	3/8" FPT	S	V
8.702-304.0	8000-343-236	Demand	12V DC	1.2	60	3/8" FPT	V	V
8.702-300.0	8000-543-236	Demand	12V DC	1.4	60	3/8" FPT	S	V
8.702-296.0	8000-543-238	Demand	12V DC	1.6	100	3/8" FPT	S	V
8.702-335.0	8030-813-239	Demand	12V DC	1.5	150	3/8" FPT	S	V
8.702-302.0	8002-793-238	Demand	12V DC	1.7	100	3/8" FPT	S	E
8.702-311.0	8000-532-256	Demand	115V	1.4	60	3/8" FPT	S	V
8.702-307.0	8000-033-236	Demand	115V	1.0	60	3/8" FPT	V	V
8.702-306.0	8000-533-236	Demand	115V	0.98	60	3/8" FPT	S	V
8.702-334.0	8000-812-288	Bypass	115V	1.4	100	3/8" FPT	S	V
8.702-308.0	8000-813-238	Demand	115V	1.6	100	3/8" FPT	S	V
8.702-338.0	8000-713-238	Demand	115V	1.6	100	3/8" FPT	S	E

**2088 PREMIUM SERIES - SELF-PRIMES UP TO 12 FT. - BUILT-IN BACK CHECK**

8.702-305.0	2088-343-135	Demand	12V DC	3.0	45	1/2" - 14M	S	V
8.702-303.0	2088-313-145	Demand	12V DC	3.6	45	1/2" - 14M	S	V
8.702-301.0	2088-712-244	Demand	12V DC	3.8	40	1/2" - 14M	S	E
8.702-310.0	2088-394-154	Demand	115V	3.2	40	1/2" - 14M	S	V

**4111 - DOUBLE HEAD**

8.702-339.0	4111-035	Demand	12V	7.0	45	1/2" - 14M	S	V
-------------	----------	--------	-----	-----	----	------------	---	---

**166 - AIR DRIVE**

8.702-317.0	166-200-56	Demand	AIR	1.25	65	3/8" Barb	E	E
-------------	------------	--------	-----	------	----	-----------	---	---

\*V = Viton E = EPDM S = Santoprene

Note: These units are designed to withstand many harsh chemicals. However, because compounds and concentrations of materials pumped through these units are beyond the manufacturer's control, the manufacturer DOES NOT PROVIDE A WARRANTY on the wet-end of the pump.

## AQUATEC 550 SERIES DIAPHRAGM PUMP

These pumps can either be controlled by a pressure switch ("demand" mode) or an external power control device. When required, an integrated bypass can be incorporated to help regulate pressure levels.



- Powerful flow rates up to 5.5 GPM / 21 LPM at pressures up to 80 PSI / 5.5 Bar
- Patented 5-Chamber diaphragm and piston design
- Quiet noise levels and with minimal pulsations

PART NO.	AQUATEC MODEL NO.	VOLTAGE	MAX FLOW	MAX PSI	PORTS	DIAPHRAGM*	VALVES*
8.750-812.0	25513-1E11-M638	12V DC	5.3	60	1/2" NPT	S	E

\*V = Viton E = EPDM S = Santoprene

## INDUSTRIAL CHEMICAL SPRAYER

Excellent pre-prep chemical applicator. Trigger control, demand flow, wall-mount cabinet, enclosed pump unit pulls chemical from a bulk tank and delivers it through 100' lightweight hose for low-pressure stream / cone or mist application. Operator simply squeezes trigger for instant application.



- Diaphragm Pump Units
- PSI: 60
- Choice of 12V DC or 110V DC
- 100-Foot Hose
- Adjustable nozzle for cone mist to straight stream
- Durable Santoprene and Viton-Wetted Parts

PART NO.	DESCRIPTION	MOTOR	PSI	GPM
<b>WALL MOUNT / CABINET SPRAYER</b>				
8.906-090.0	Chemical Applicator	115V AC	60	1.15
8.906-089.0	Chemical Applicator	12V DC	60	1.25

Note: These units are designed to withstand many harsh chemicals. However, because compounds and concentrations of materials pumped through these units are beyond the manufacturer's control, the manufacturer DOES NOT PROVIDE A WARRANTY on the wet-end of the pump.

## SPRAYMAX TRIGGER GUN

For pest control applications.



- PSI: 1000
- Temperature: 200°F
- Compare to JD-9, Mag-1, Robco and Ges
- Adjusts from fine mist to straight stream
- Drip-Free Shutoff
- Crafted for all-day comfortable use
- Larger trigger for 4-fingered grip

PART NO.	DESCRIPTION
8.708-995.0	With 1/2" Inlet
8.709-028.0	Repair Kit

## M23 TRIGGER VALVES

Versatile hand-held trigger valves for chemical or water-flow control.



- PSI: 700
- GPM: 18.5
- 1/2" FPT Inlet/Outlet
- Lock-On Trigger Loop

PART NO.	DESCRIPTION
<b>ALUMINUM BODY - SS / BR VALVE</b>	
8.708-982.0	Trigger Valve - Viton
<b>PLASTIC BODY - SS / BR VALVE</b>	
8.708-983.0	Trigger Valve - Viton
8.708-984.0	Trigger Valve - Buna

### TURBINE SERIES GUNS

Forged-brass housings, stainless-steel lances, mist cone to straight stream adjustment, on/off control, lock-on trigger, 1/2" BSP inlet Viton seals, up to 850 PSI at 140°F.



- PSI: 850
- 1/2" BSP Male Inlet
- Weight: 4 lbs.
- Standard 15 x 1 LRT(4.5 mm)
- 62 ft - Reach, Straight Stream at 850 PSI, 31.5 ft - Reach, Full Cone at 850 PSI

PART NO.	DESCRIPTION	GPM	BARREL
8.708-990.0	Long Range Turbine	30	21
8.708-989.0	Turbine	25	17

### TRIGGER-CONTROL SPRAY LANCES

Excellent for low-pressure chemical applications up to 150 PSI. Available in either plastic- or brass-lance tube. Works well with neutral, alkaline or mild acid solutions.



- Steel Trigger and Service Wrench
- Plastic Valve Body
- Brass-Needle Plunger
- Filter Screen in Nozzle Housing
- Cone Nozzle Adjusts 0-80°
- 24" Lance - Brass or Plastic
- Standard 11/16" outlet thread for standard low-pressure nozzle
- Accepts the adjustable cone nozzles or standard tip-jet nozzles (11/16 nozzle thread)

PART NO.	DESCRIPTION
<b>TRIGGER LANCE</b>	
8.902-777.0	Brass without Nozzle
8.902-778.0	Plastic without Nozzle
8.708-977.0	Plastic with Red Nozzle
8.925-822.0	Brass with Red Nozzle
8.700-493.0	Needle Valve and Seal Kit

PART NO.	DESCRIPTION	80° STRAIGHT CONE
<b>ADJUSTABLE NOZZLE - GPM @ 40 PSI / ADJUST 0-80°</b>		
8.708-980.0	#2 Red	.545 .204

### GUN ASSEMBLY - 910 SPOT SPRAY

High-pressure trigger gun adapted to spot spray application.



- Durable and comfortable
- 12" Plated Steel Lance
- 1/4" Hose Barb Inlet
- #2 Blue Adjustable Nozzle

PART NO.	DESCRIPTION
8.904-088.0	910 Spot Spray Gun Assembly

### BRASS PRESSURE REGULATOR



- Durable and Strong
- 3/4" FPT Outlet
- Temperature: 120°F
- Weight: 10.3 oz.
- Sprayers pumping up to 15 GPM
- Adjustable Pressure Ranges
- Stainless-Steel Spring
- Tee-Handle Adjustment Screw
- 3/4" MPT Inlet
- Knurled locknut for ease of locking in adjustment

PART NO.	DESCRIPTION	PSI
8.712-557.0	3/4" FPT Outlet x 3/4" MPT Inlet	0-300
8.712-558.0	3/4" FPT Outlet x 3/4" MPT Inlet	300-700

### HEAVY-DUTY SWIVELS

Live swivels help prevent twisted and tangled hose.



- PSI: 600
- Brass Body, Stainless-Steel Bolt
- Viton Seals
- 1/2" MPT inlet and 1/2" outlet

8.708-996.0

PART NO.	DESCRIPTION	PSI
8.708-996.0	Swivel 1/2" M x F	600
8.708-997.0	Swivel 3/4" M X F	600

## TRIGGER-JET SPRAY LANCES - TEEJET

Low-pressure chemical application lance will tolerate mild acid solutions.



- PSI: 150
- Diaphragm Shut-Off Valve
- Hand-Grip Trigger Control
- Plastic lance tube resistant to acids and agricultural chemicals
- Excellent for mild acids or alkali chemicals
- Polypropylene Body EPDM Seals STD
- 11/16" - Nozzle Connect Outlet

PART NO.	DESCRIPTION
<b>TRIGGER LANCE (TIP NOT INCLUDED)</b>	
8.709-182.0	24", 1/4" FPT Inlet, Viton
8.709-184.0	24", 3/8" HB Inlet, Viton
<b>TRIGGER VALVE ONLY</b>	
8.709-185.0	3/8" HB Inlet, 11/16" Outlet, Viton
8.709-186.0	1/4" HB Inlet, 11/16" Outlet, Viton
8.709-187.0	1/4" FPT Inlet, 11/16" Outlet, Viton
<b>PARTS AND ACCESSORIES - TRIGGER JET LANCE</b>	
8.709-188.0	Adapter, 11/16" x 11/16" PP
8.709-189.0	24" Lance Tube Only
8.709-190.0	24" Lance Tube with Seals and Fittings
<b>TIGGER JET NOZZLES - POLYPROPYLENE, ADJUST FROM 00 TO 600</b>	
8.709-192.0	Yellow Core (x 3), .23 GPM / 60 PSI
8.709-193.0	Green Core (x 5), .37 GPM / 60 PSI
8.709-194.0	Red Core (x 6), .45 GPM / 60 PSI
8.709-195.0	Gray Core (x 8), .57 GPM / 60 PSI
8.709-196.0	Brown Core (x 12), .84 GPM / 60 PSI
8.709-197.0	Orange Core (x 18), 1.2 GPM / 60 PSI

## LONG RANGE TIP

Best used with long-range turbine gun.



- PSI: 850
- GPM: 24.4
- 15 x 1 Long-Range Tip
- Brass Body
- 77 ft Max Throw Range

PART NO.	ORIFICE DIA (MM)	DEGREES
8.708-998.0	3.5	45°
8.708-999.0	4.0	45°
8.709-000.0	4.5	50°
8.709-001.0	5.0	55°
8.709-002.0	5.5	60°
8.709-003.0	6.0	65°
8.709-004.0	7.0	75°

## LOW-FLOW BRASS PRESSURE REGULATOR

- 1/2" MPT Inlet
- 1/2" Outlet
- Temperature: 120°F
- Weight: 10.3 oz.
- For Sprayers Pumping Up to 5 GPM
- Durable and Strong Brass Construction
- Stainless-Steel Spring
- Positive Viton Seal to Prevent Leakage
- Knurled Locknut for Easy Adjustment



PART NO.	DESCRIPTION
8.712-553.0	200-650 PSI
8.712-554.0	0-300 PSI

## NYLON PRESSURE REGULATOR

Maximum corrosion resistance.



- Male Inlet / Female Outlet
- Temperature: 120°F
- Weight: 4 oz.
- Up to 15.0 GPM
- Stainless-Steel Spring
- Positive Viton Seal to Prevent Leakage and Provide Best Chemical Resistance
- Knurled Locknut for Easy Adjustment
- Tee-Handle Adjustment Screw
- Choice of 1/2" or 3/4" Inlet / Outlet

PART NO.	INLET	OUTLET	ADJUSTABLE PRESSURE RANGE
8.712-555.0	1/2"	3/4"	0-250 PSI
8.712-552.0	3/4"	3/4"	0-250 PSI
8.712-556.0	3/4"	3/4"	0-400 PSI



**BULKHEAD FITTINGS**



- Black Polypropylene
- Double-Threaded with EPDM Gasket
- Opening Same Size as Outside Diameter

PART NO.	FPT	HOLE DIA
8.705-336.0	1/2"	1-5/8"
8.705-338.0	3/4"	1-5/8"
8.705-144.0	3/4"	1-3/4"
8.705-145.0	1"	1-3/4"
8.705-339.0	1"	2-1/2"
8.705-341.0	1-1/4"	2-1/2"
8.705-342.0	1-1/2"	2-1/2"
8.705-146.0	1-1/2"	3"
8.705-147.0	2"	3"
8.705-343.0	2"	3-1/8"

**GASKET FOR ABOVE**

8.705-337.0	Fits 1/2", 3/4"
8.705-340.0	Fits 1", 1-1/4", 1-1/2"
8.705-344.0	Fits 2"

**BULKHEAD / TANK FITTINGS - BRASS**



- Use to drain or remove liquids from tanks, drums, etc.
- Heavy-Duty Brass
- Includes nut and aluminum grip water

PART NO.	OVERALL LENGTH	MOUNTING HOLE DIAMETER
8.705-139.0	1/8" x 1.5"	5/8"
8.705-140.0	1/4" x .94"	3/4"
8.705-141.0	1/4" x 1.5"	3/4"
9.802-149.0	3/8" x 1.3"	1"
9.802-150.0	1/2" x 1.5"	1-1/8"

Note: Installation requires access to inside of tank

**DIAPHRAGM CHECK VALVES - NYLON**

For drip-free spraying.



- PSI: 125
- Operating Pressure PSI: 10
- GPM: 2.0
- Nylon Body, Polypropylene End Cap - EPDM - Diaphragm
- 1/4" MPT Inlet, 11/16" - 16 Male Outlet Nozzle Thread
- Spring-backed diaphragm for positive actions

PART NO.	DESCRIPTION
8.709-377.0	Diaphragm Check Valves

- DO NOT USE... Polypropylene for: gasoline, nitric acid, trichlorethylene, toluene, aromatic hydrocarbons or kerosene. Polypropylene "P" - black / glass reinforced
- DO NOT USE... Nylon for: hydrochloric acid, chlorine, fluorine, nitric, xylene or phosphoric or sulfuric acids. Nylon 6/6 "N" white / natural color.

**TWIN-DIAPHRAGM SPOT SPRAY PUMP**

**FLOJET**



- PSI: 35 (#8 Tip)
- GPM: 1.0 (Open)
- 3/8" Hose Barb Inlet / Outlet
- Self-Priming to 2.5 Feet
- Operating Temperature: 40° - 110°F
- Liquid Temperature Max: 110°F
- 5 Amp Fuse
- Dry Weight: 1.3 lbs.
- Chemical-Resistant Valves and Diaphragm
- Compact automatic on-demand operation
- Sealed pressure switch automatically stops pump when discharge valve opens and closes
- Self-priming so pump can be located above supply tank
- Can run dry for extended periods without damage
- Built-In Thermal Protection on 12V DC Motor
- Low-Amp Draw (2.5 at 25 PSI, 4.0 at 35 PSI)

PART NO.	DESCRIPTION	OPEN
8.702-326.0	Spot Spray Pump, Max 35 PSI, 12V DC	1.0

## PLASTIC FITTINGS

For cater and chemical supply lines. Ideal for use with most alkaline-based detergents, most agricultural chemicals, ethanol, and most ammonium and sodium-based compounds.

■ PSI: 150

■ Temperature Max: 140°F at 90 PSI

■ Temperature Max: 90°F at 150 PSI



8.705-265.0



8.705-289.0



8.705-317.0



8.705-335.0

PART NO.	DESCRIPTION	BARB X MPT
<b>HOSE BARBS - BARB X MPT</b>		
8.705-262.0	Poly	1/4" x 1/4"
8.705-264.0	Poly	1/4" x 3/8"
8.705-263.0	Poly	3/8" x 1/4"
8.705-265.0	Poly	3/8" x 3/8"
8.705-268.0	Poly	1/2" x 3/8"
8.705-270.0	Poly	5/8" x 1/2"
8.705-277.0	Nylon	1/4" x 1/4"
8.705-280.0	Nylon	1/4" x 3/8"
8.705-278.0	Nylon	3/8" x 1/4"
8.705-281.0	Nylon	3/8" x 3/8"
8.705-284.0	Nylon	3/8" x 1/2"
8.705-282.0	Nylon	1/2" x 3/8"
8.705-285.0	Nylon	1/2" x 1/2"
8.705-288.0	Nylon	1/2" x 3/4"
8.705-283.0	Nylon	5/8" x 3/8"
8.705-286.0	Nylon	5/8" x 1/2"
8.705-289.0	Nylon	5/8" x 3/4"
8.705-287.0	Nylon	3/4" x 1/2"
8.705-290.0	Nylon	3/4" x 3/4"
8.705-291.0	Nylon	1" x 3/4"

PART NO.	DESCRIPTION	BARB X MPT
<b>90° BARB X MPT ELBOWS</b>		
8.705-293.0	Poly	1/4" x 1/4"
8.705-296.0	Poly	1/4" x 3/8"
8.705-294.0	Poly	3/8" x 1/4"
8.705-298.0	Poly	3/8" x 3/8"
8.705-301.0	Poly	3/8" x 1/2"
8.705-295.0	Poly	1/2" x 1/4"
8.705-299.0	Poly	1/2" x 3/8"
8.705-303.0	Poly	1/2" x 1/2"
8.705-307.0	Poly	1/2" x 3/4"
8.705-304.0	Poly	5/8" x 1/2"
8.705-308.0	Poly	5/8" x 3/4"
8.705-305.0	Poly	3/4" x 1/2"
8.705-310.0	Poly	3/4" x 3/4"
8.705-300.0	Nylon	3/8" x 1/2"
8.705-306.0	Nylon	1/2" x 3/4"
8.705-309.0	Nylon	3/4" x 3/4"
<b>HEX NIPPLE - MPT X MPT</b>		
8.705-316.0	Poly	1/4" x 1/4"
8.705-317.0	Poly	3/8" x 3/8"
8.705-323.0	Poly	1/2" x 3/8"
8.705-319.0	Poly	1/2" x 1/2"
8.705-326.0	Poly	3/4" x 1/2"
8.705-321.0	Poly	3/4" x 3/4"
8.705-324.0	Nylon	1/2" x 1/4"
8.705-318.0	Nylon	1/2" x 1/2"
8.705-320.0	Nylon	3/4" x 3/4"
<b>ELBOWS - BARB X BARB</b>		
8.705-335.0	Poly	3/8" x 3/8"
<b>TEES BARB X BARB X BARB</b>		
8.705-327.0	Nylon	1/4" B x B x B
8.705-328.0	Nylon	3/8" B x B x B
<b>"PUSH-ON" HOSE BARBS - NORMALLY DOES NOT REQUIRE CLAMPS</b>		
8.705-346.0	Nylon	1/4" B x 1/4" FPT

**Equipment**

333 ..... 2  
 500 ..... 3  
 700 ..... 4  
 800 ..... 5  
 900/1400 ..... 7  
 1200 ..... 13  
 1700 ..... 25  
 1800 ..... 9  
 5700/5800 ..... 10  
 9400 ..... 16  
 BD ..... 18  
 BDE ..... 24  
 BX ..... 19  
 CWC ..... 28  
 DB ..... 20  
 ET ..... 27  
 HD ..... 21  
 HD ..... 26  
 LP/NG ..... 6  
 TETON ..... 23

**Branded Parts**

BURNER REPLACEMENT PARTS ..... 108  
 FASPUMP QUICK CHANGE PUMP ASSEMBLIES ..... 99  
 HOTSY 32 OZ. COMPACT AIRLESS FOAMER ..... 109  
 HOTSY 360° PIVOT HOSE REELS &  
 CONNECTOR HOSE OPTIONS ..... 93  
 HOTSY ADJUSTABLE FAN NOZZLE ..... 95  
 HOTSY ADJUSTABLE NOZZLE ..... 96  
 HOTSY BRACKET SOCKETS ..... 92  
 HOTSY CITY WATER PRESSURE / FLOW TEST KIT ... 110  
 HOTSY COIL INSULATION ..... 106  
 HOTSY COILS ..... 106  
 HOTSY COLD WATER LANCE ..... 89  
 HOTSY DETERGENT FLOW METER ..... 106  
 HOTSY DOWNSTREAM CHEMICAL INJECTORS ..... 104  
 HOTSY DRUM STICKS AND TOTE STICKS ..... 110  
 HOTSY DUAL LANCE ..... 89  
 HOTSY FIXED BASE HOSE REELS & MOUNTING  
 BRACKET OPTIONS ..... 93

HOTSY FLOAT TANK ..... 105  
 HOTSY FLOW SWITCH ..... 105  
 HOTSY FUEL FILTER/WATER SEPARATOR ..... 91  
 HOTSY FUEL FILTER/WATER SEPARATOR ..... 91  
 HOTSY GUNS ..... 89  
 HOTSY HAND HYGIENE SPRAY DISPENSERS ..... 110  
 HOTSY HIGH/LOW ADJUSTABLE FAN NOZZLE ..... 95  
 HOTSY HOSE REELS ..... 92  
 HOTSY HOT WATER LANCE ..... 89  
 HOTSY HV FOAMER WITH GAUGES ..... 109  
 HOTSY INLET CHEMICAL INJECTOR ..... 105  
 HOTSY INTERNAL TANK FOAMERS ..... 109  
 HOTSY LANCE GRIP ..... 89  
 HOTSY MAINTENANCE KIT ..... 104  
 HOTSY NON-PIVOT REEL BRACKETS ..... 92  
 HOTSY NOZZLE PROTECTOR ..... 95  
 HOTSY NOZZLES ..... 95  
 HOTSY POLY TANK 2-WHEELED FOAMER ..... 109  
 HOTSY PRESSURE RELIEF VALVES ..... 105  
 HOTSY PRESSURE SWITCH ..... 105  
 HOTSY PRODUCT MIXING STATIONS ..... 109  
 HOTSY PUMP OIL ..... 104  
 HOTSY PUMP REPAIR KIT - CERAMIC SLEEVE KIT ... 103  
 HOTSY PUMP REPAIR KIT - COMPLETE SEAL KIT .... 102  
 HOTSY PUMP REPAIR KIT -  
 PLUNGER OIL SEAL KIT ..... 103  
 HOTSY PUMP REPAIR KIT - SEAL KIT ..... 102  
 HOTSY PUMP REPAIR KIT SELECTION CHART ..... 100  
 HOTSY PUMP REPAIR KIT SELECTION CHART  
 (CONTINUED) ..... 101  
 HOTSY PUMP REPAIR KIT - VALVE KIT ..... 102  
 HOTSY PUMPS ..... 98  
 HOTSY PUMPS (CONTINUED) ..... 99  
 HOTSY PUMP TOOL KITS ..... 104  
 HOTSY R1 1-WIRE 4000 PSI HOSE ..... 90  
 HOTSY R2 2-WIRE 5000 PSI HOSE ..... 90  
 HOTSY R2 2-WIRE 6000 PSI HOSE ..... 90  
 HOTSY SIDE HANDLE ..... 89  
 HOTSY ST-56 ROLLOVER NOZZLE HEAD ..... 96  
 HOTSY STACKABLE HOSE REELS & ACCESSORIES ..... 94  
 HOTSY THERMOSTATS ..... 105  
 HOTSY TIMED ENTRYWAY FOAM SANITIZER ..... 110

HOTSY TOUCH-UP PAINT.....	91	LIQUID FOAMER .....	39
HOTSY TUFF-FLEX 1-WIRE 3000 PSI BLUE NON-MAR HOSE.....	91	MAX STOCK SYMBOL.....	1
HOTSY TUFF-FLEX 2-WIRE 4500 PSI BLUE NON-MAR HOSE.....	91	MIRACLE WIZZ .....	39
HOTSY TWIST QUICK COUPLERS.....	96	NUBLEND BARRAGE MULTI-PURPOSE DISINFECTING SPRAY.....	41
HOTSY TWO-GUN TEE COUPLER.....	96	NUBLEND DISINFECTANT 220 MULTI-PURPOSE DISINFECTING SPRAY.....	40
HOTSY ULTIMATE FOAMER WITH GAUGES.....	109	NYTRO .....	33
HOTSY UNI-BODY COMBO DEMO FOAMER.....	110	PAINT & POWDER COAT STRIPPER .....	42
HOTSY UNLOADERS.....	104	PANEL WASH.....	33

**Detergents**

400 WAX .....	37	POWER SHINE .....	33
ADVANCED FORMULA ALUMINUM BRIGHTENER .....	36	POWER SHINE PLUS .....	38
AERO ONE .....	38	PRODUCT 31 .....	31
BLUE THUNDER.....	31	RINSE AID.....	34
BREAKTHROUGH! .....	31	RIPPER I .....	34
CARBOCHLOR .....	38	RIPPER II .....	35
CARBON-ATE.....	32	RIPPER III.....	35
CARBON-ATE PLUS .....	38	SALT LICK.....	37
CITRUS CLEAN .....	35	SHOP FLOOR CLEANER .....	43
COIL CONDITIONER .....	39	SUPER X.....	31
CON-B-GONE.....	39	SUPER XL.....	32
DUCT BOSS – HOOD AND DUCT DEGREASER .....	39	TRANSPORT VEHICLE WASH.....	32
ENVIRO-CLEAN .....	37	TUBMATE ALL PURPOSE DETERGENT (POWDER).....	41
ENVIRO GARD 2 .....	37	TUBMATE GENERAL PURPOSE DETERGENT .....	41
ENVY SUPER CONCENTRATE.....	32	TUBMATE IRON & STEEL CLEANER.....	41
FAT CAP GRAFFITI REMOVER BRICK, MASONRY & CONCRETE .....	40	TUBMATE TORQUE .....	41
FINISH LINE .....	42	VAPOR CORROSION INHIBITOR .....	42
FLEET WASH.....	33	VEHICLE PRE-SOAK .....	34
FLOOR WASH .....	42	VEHICLE TIRE & RIM CLEANER.....	34
HOTSY “99” .....	39	VERDE ALL PURPOSE.....	37
HOTSY BROWN.....	35	VITAL OXIDE CLEANER & DISINFECTANT .....	40
HOTSY DEFOAMER.....	42	YELLOW FEVER .....	36
HOTSY ORANGE .....	36		
HOTSY PHOSPHATIZER NO. 2 .....	40		
HOTSY POLISHED ALUMINUM & STAINLESS STEEL CLEANER .....	36		
HOTSY RED.....	33		
HOTSY'S ALUMINUM AND STAINLESS STEEL CLEANER.....	36		

## Floor Care Equipment

EB 30/1.....	46
KM 70/20 C.....	47
KM 70/30 C BP ADV.....	48
KM 75/40 W BP.....	49
KM 85/50 R BP.....	50
KM 90/60 RBP.....	51
PUZZI™ 8/1 C.....	52
CADET 7.....	53
BRC 30/15.....	54
CV 300.....	55
BV VAC PAC™ HEPA SERIES.....	56
NT 25/1 AP.....	57
NT 22/1 AP.....	58
NT 30/1 TACT TE.....	59
NT 30/1 ACCESSORIES.....	60
NT 48/1.....	61
NT 68/1.....	62
BR 35/12 C BP.....	63
BD 38/12 C BP.....	64
BD 50/50 C CLASSIC BP.....	65
B 40 W BP.....	66
B 40 C/W BP ACCESSORIES.....	67
B 60 W BP.....	68
B 60 W BP ACCESSORIES.....	69
B 80 W BP.....	70
B 80 W BP ACCESSORIES.....	71
BD 70/75 W BP CLASSIC.....	72
BD 80/100 W BP CLASSIC.....	73
B 110 R.....	74
B 110 R ACCESSORIES.....	75
B 150 R BP.....	76
B 150 R BP EQUIPMENT & ACCESSORIES.....	77
CLEANING HEADS FOR B SERIES SCRUBBERS.....	78
CLEANING HEADS FOR B SERIES SCRUBBERS.....	79
CLEANING HEADS & BRUSHES.....	80
CLEANING HEADS & BRUSHES.....	81
BDS 51/175 C.....	82
SGV 6/5.....	83
SG 4/4.....	84
HD 2.0/1000 DUAL MISTER & DUAL MISTER CART AN ALL-IN-ONE MISTER AND PRESSURE WASHER.....	85

PS 4/7 BP MISTER VITAL OXIDE™ HOSPITAL DISINFECTANT.....	86
AB 84.....	87
SG BP.....	88

## Generic Parts

### A

ACCUMULATOR BY INTERPUMP.....	208
ACCUMULATOR - PULSE DAMPENER.....	208
ADAPTERS - BRASS.....	150
ADAPTERS - HIGH PSI - STEEL.....	155
ADMIRAL PUMP REPAIR KITS.....	190
AG HOSE - COMPLETE ASSEMBLY.....	141
AG HOSE - ORANGE PVC-RIBBED - BULK.....	141
AIR-FILTER / REGULATORS.....	278
AIR VALVE - COIL BLOW OUT.....	234
ANTI-SEIZE COMPOUND.....	209
AP1000 OPEN GUN.....	130
AP DUMP GUN.....	130
AP UNINSULATED LANCES.....	133
AQUATEC 550 SERIES DIAPHRAGM PUMP.....	287
AR DIRECT DRIVE PUMPS.....	202
AR PUMP KITS.....	204
AR PUMP REPAIR KIT SELECTION CHART.....	203
AR TRIPLEX CERAMIC PLUNGER PUMPS.....	201

### B

BALDOR MOTORS - C-FACE OPEN DRIP PROOF (ODP).....	239
BALDOR MOTORS - OPEN DRIP PROOF (ODP).....	240
BALL VALVES - 454 SERIES, POLYPROPYLENE, LOW PSI.....	232
BALL VALVES - 2940/3830 MINI SERIES, LOW PSI.....	232
BALL VALVES - BKH SERIES, HIGH PSI.....	231
BALL VALVES - FORGED-BRASS, LOW PSI.....	230
BALL VALVES - MINI, LOW PSI.....	230
BALL VALVES - MODEL 727, 3 WAY.....	232
BALL VALVES - NICKEL-PLATED BRASS, LOW PSI.....	231
BALL VALVES - PVC, LOW PSI.....	231
BALL VALVES - RKH SERIES - STAINLESS-STEEL, HIGH PSI.....	231

BALL VALVES - SHUT-OFF, HIGH PSI.....	231	<b>C</b>	
BALL VALVES - STAINLESS-STEEL, LOW PSI.....	230	CAM SWITCHES - 2-POSITION.....	272
BALL VALVES - STAINLESS-STEEL, LOW PSI, ONE PIECE.....	231	CAM SWITCHES - 3-POSITION - "BIG BOOT" .....	270
BALL VALVES - T-601 SERIES COMPACT PVC, LOW PSI.....	232	CAM SWITCHES - 3-POSITION - "ELEKTRA" UNIVERSAL.....	271
BARBS - PUSH-N-LOCK.....	152	CAM SWITCHES - 3-POSITION - MACHINE CONTROL.....	270
BATTERY BOXES WITH COVER, MARINE STYLE.....	276	CAM SWITCHES - ON / OFF WITH BOX - "ELEKTRA".....	271
BIG GUN.....	129	CAM SWITCHES - ROTARY - SALZER.....	265
BIG STAINLESS-STEEL LANCES & SIDE HANDLES.....	133	CAM SWITCHES WITH & WITHOUT BOX.....	270
BLOWER WHEELS - BECKETT.....	249	CAR WASH BOOMS, "REFLEX".....	279
BLOWER WHEELS - WAYNE.....	248	CAT TRIPLEX PUMPS.....	205
BOOKS - AMAZING POCKET REFERENCE.....	120	CERAMIC PLUNGERS.....	200
BRASS PRESSURE REGULATOR.....	288	CERAMIC UNITIZED BALL VALVE.....	127
BREAKER SWITCHES.....	273	CHECK VALVES - 460 SERIES, HIGH PSI.....	229
BRIGGS & STRATTON ENGINE PARTS.....	238	CHECK VALVES / BACKFLOW PREVENTOR - T533 MODEL, VACUUM BREAKER.....	229
BRIGGS & STRATTON ENGINES - GASOLINE.....	238	CHECK VALVES - PVC, LOW PSI.....	229
BRUSHES.....	117	CHECK VALVES - SPRING LOADED, HIGH PSI.....	229
BRUSHES - FOAM & ACCESSORIES.....	278	CHECK VALVES - SPRING LOADED, LOW PSI.....	229
BULKHEAD FITTINGS.....	290	CHECK VALVES - STAINLESS-STEEL, HIGH PSI.....	228
BULKHEAD / TANK FITTINGS - BRASS.....	290	CHECK VALVES - SWING ACTION, LOW PSI.....	228
BURNER CHART - BECKETT.....	245	CHEMICAL INJECTORS - 400 SERIES.....	225
BURNER CHART - WAYNE.....	247	CHEMICAL INJECTORS - 505 SERIES STAINLESS-STEEL.....	226
BURNER CONTROLLER AND CONTRACTOR TOOL - GENISYS™.....	246	CHEMICAL INJECTORS - ADJUSTABLE, WITH QUICK-CONNECT.....	226
BURNER IGNITOR / BASE PLATES - BECKETT.....	251	CHEMICAL INJECTORS - AMERIMAX SERIES.....	223
BURNER IGNITORS - ALLANSON.....	251	CHEMICAL INJECTORS - AMERIMAX SERIES - QUICK-COUPLED ASSEMBLIES.....	223
BURNER IGNITORS - BECKETT.....	249	CHEMICAL INJECTORS - BRASS.....	226
BURNER IGNITORS - WAYNE.....	251	CHEMICAL INJECTORS - HI-LO.....	225
BURNER MOTORS.....	249	CHEMICAL INJECTORS / PRESSURE REDUCER - EXTACT-A-FLOW.....	226
BURNER PARTS - BECKETT - ELECTRODE / INSULATOR ASSEMBLY.....	246	CHEMICAL INJECTORS - ROBOKIM.....	224
BURNER PARTS - BECKETT - MISC REPAIR.....	246	CHEMICAL INJECTORS - ROBOKIM QUICK-COUPLED ASSEMBLIES.....	224
BURNER REPAIR PARTS / COMMON - BECKETT & WAYNE.....	248	CHEMICAL INJECTORS - ST-60 SERIES.....	223
BURNER REPAIR PARTS - WAYNE.....	248	CHEMICAL INJECTORS - ST-62 VARIABLE.....	224
BURNERS - BECKETT 14V DC.....	245	CHEMICAL INJECTORS - ST-64, UP STREAM.....	224
BURNERS - BECKETT - 115V / 230V.....	245	CHEMICAL INJECTORS - STAINLESS-STEEL.....	223
BURNERS - WAYNE.....	247	CHEMICAL INJECTORS - STAINLESS-STEEL.....	226
BURNER TRANSFORMERS - ALLANSON.....	250	CHEMICAL METERING VALVES - BRASS.....	233
BURNER TRANSFORMERS - BECKETT.....	250		
BURNER TUNE UP KIT - BECKETT.....	249		
BUSHINGS - BRASS.....	150		



CHEMICAL METERING VALVES -  
 DUAL - ST-66 MODEL..... 233

CHEMICAL METERING VALVES - FLOW CONTROL..... 233

CHEMICAL METERING VALVES -  
 FLOW SELECTOR, 3 & 4 WAY..... 232

CHEMICAL METERING VALVES -  
 SERIES 28, FLOW CONTROL..... 233

CHEMICAL METERING VALVES -  
 SERIES 28, FLOW CONTROL..... 233

CHEMICAL METERING VALVES - ST-61..... 223

CIRCUIT BREAKERS..... 269

COMET PUMPS AND PUMP KITS..... 206

COMPLETE WHEELS..... 277

CONNECTOR CLAMPS - ROMEX (METAL)..... 273

CONNECTOR HOSE..... 144

CONNECTOR HOSE - 2' - 10'..... 143

CONNECTORS - DP - CUTLER-HAMMER..... 264

CONNECTOR / STRAIN RELIEFS - LIQUID TIGHT -  
 FOR CABLE, WIRE & TUBING..... 274

CORD CAPS & PLUGS..... 273

COUPLERS - LANCE & NOZZLE COUPLERS..... 177

COUPLERS SECTIONS - BROWNING / LOVEJOY..... 243

COUPLINGS - FIELD ATTACHABLE..... 142

COUPLINGS - FPT - GALVANIZED..... 157

COUPLINGS - HEX - HEAVY WALL STEEL..... 155

COUPLINGS - HEX - HIGH PSI - STEEL..... 155

CRIMP FITTINGS..... 142

CROSSES - FPT - 4 CONNECTS - HIGH PSI - STEEL... 156

CROSSES - FPT - BRASS EXTRUDED..... 152

**D**

DIAPHRAGM CHECK VALVES - NYLON..... 290

DIAPHRAGM PUMP UNITS..... 286

DIGITAL POWER MONITOR..... 272

DISINFECTANT - VITAL OXIDE..... 126

DRAFT DIVERTERS & RAIN CAPS..... 254

DRAIN COCKS..... 153

DRUM PUMPS - RED HEAD..... 116

DRUM PUMPS - TOOLS / ACCESSORIES..... 116

DRUM / TANK PUMP - CRANK STYLE..... 116

DUAL LANCES..... 131

DUAL LANCES..... 131

DUAL TRIGGER LANCE..... 132

DUMP GUN..... 130

**E**

ECONOMY TRIGGER GUN..... 127

ELBOWS - 45°..... 155

ELBOWS - 90° - BRASS..... 151

ELBOWS - 90° - FPT - GALVANIZED..... 157

ELBOWS - HIGH PSI - STEEL..... 156

ELBOWS - STREET - 90° -  
 MPT X FPT - GALVANIZED..... 157

ELBOWS - STREET-BRASS..... 151

ELBOWS - STREET - HIGH PSI - STEEL..... 156

ENGINE PARTS - KOHLER LOMBARDINI..... 239

ENGINES - KOHLER LOMBARDINI - DIESEL..... 238

**F**

FIBERGLASS TELESCOPING WANDS..... 134

FILTERS - BLUE TOP..... 161

FILTERS - CHEMICAL - BRASS / PLASTIC..... 158

FILTERS - CHEMICAL - LEGACY BRASS..... 157

FILTERS - CHEMICAL LINES WITH FILTER..... 158

FILTERS - CHEMICAL - "THE BIG ONE"..... 157

FILTERS - CLEAR BOWL..... 158

FILTERS - FUEL..... 160

FILTERS - FUEL - CLEAR BOWL..... 161

FILTERS - FUEL ELEMENT - GENERAL..... 161

FILTERS - FUEL / WATER SEPARATOR - LEGACY..... 161

FILTERS - FUEL / WATER SEPARATOR - RACOR..... 162

FILTERS - FUNNEL - RACOR..... 162

FILTERS - HIGH-VOLUME..... 161

FILTERS - IN-LINE - ALL METAL..... 158

FILTERS - IN-LINE - CAN-TYPE..... 159

FILTERS - IN-LINE - CLEARVIEW..... 159

FILTERS - IN-LINE - GREEN-CAP..... 158

FILTERS - IN-LINE - HEAVY-DUTY..... 158

FILTERS - IN-LINE - NOZZLE - HIGH-PRESSURE..... 160

FLANGES - INTERPUMP / GENERAL PUMP..... 210

FLANGES - LEGACY..... 210

FLAT-FREE TIRES..... 276

FLEX COUPLERS - INTERPUMP / GENERAL PUMP... 210

FLEX COUPLERS - LEGACY..... 210

FLEX COUPLINGS - BECKETT..... 246

FLEX LANCES..... 134

FLEX LINE BYPASS / SUPPLY LINE HOSE..... 143

FLOAT VALVES - ADJUSTABLE, BRONZE..... 226

FLOAT VALVES - BALLS, COPPER & PLASTIC .....	227	FUEL PUMPS & REPLACEMENT PARTS - SUNTEC.....	250
FLOAT VALVES - BRASS.....	228	FUEL SOLENOID VALVE - 12V DC KIP.....	251
FLOAT VALVES - BRASS FLOAT WITH BALL & STEM.....	227	FUEL SOLENOID VALVES / COILS - SUNTEC.....	252
FLOAT VALVES - DIAPHRAGM.....	227	FUEL TANK, 9-GALLON DIESEL.....	275
FLOAT VALVES - HUDSON.....	228	FUEL TANKS.....	275
FLOAT VALVES - KERICK.....	228	FUSES.....	269
FLOAT VALVES - PA BRASS ASSEMBLY.....	227	<b>G</b>	
FLOAT VALVES - ST-8, BRASS ASSEMBLY .....	227	GALVANIZED PIPE FITTINGS .....	157
FLOAT VALVES - STEMS.....	227	GARDEN HOSE - APEX QUALITY.....	141
FLOAT VALVES - VERTICAL .....	228	GARDEN HOSE - COLD WEATHER.....	141
FLOJET DIAPHRAGM PUMP.....	286	GARDEN HOSE FITTINGS.....	154
FLOW METERS - VISI - FLOAT.....	235	GAS CONVERSION KITS - LP - ROBERT SHAW.....	254
FLOW SWITCHES - GP - TMT .....	261	GAS JETS.....	252
FLOW SWITCHES - LEGACY.....	261	GAS PILOTS.....	254
FLOW SWITCHES - LEGACY MV60 & AP500.....	261	GAS REGULATORS - LP.....	253
FLOW SWITCHES - PHOENIX WITH PILOT .....	261	GAS REGULATORS - LP GAS CONVERSION KITS .....	253
FLOW SWITCHES - ST-5 & ST-6.....	261	GAS REGULATORS - NATURAL GAS.....	253
FLOW SWITCHES - ST-7 WITH MICRO SWITCH.....	261	GAS VALVE ACCESSORY COMPONENTS .....	259
FLOW SWITCHES - ST-505 STAINLESS-STEEL .....	262	GAS VALVES - 1" BY ROBERT SHAW .....	254
FLOW-THRU GUN .....	130	GAS VALVES - HONEYWELL.....	252
FOAMERS - ADJUSTABLE WITH TANK .....	119	GAS VALVES - LP OR NATURAL.....	259
FOAMERS - FOAM CANNON.....	117	GEARED REDUCTION UNITS - INTERPUMP / GENERAL PUMP .....	210
FOAMERS - FOAM CANNON.....	180	GEAR REDUCTION.....	209
FOAMERS - FOAM JET KIT .....	118	GENERATOR - VOLTMASTER.....	272
FOAMERS - LAFFERTY AIRLESS 10/20 SS .....	118	GENERATOR - WINCO - AC.....	272
FOAMERS - LEGACY COMPACT .....	118	GFCI MODULE.....	273
FOAMERS - LEGACY COMPACT.....	180	GFCI - WITH AND WITHOUT PLUGS & CORDS .....	274
FOAMERS - PF22 MTM HYDRO FOAM CANNON.....	118	GIANT TRIGGER GUNS.....	127
FOAMERS - SUTTNER ST-75/76 KITS.....	118	GLOVES - INDUSTRIAL DUTY .....	120
FOOT / CHECK VALVE.....	160	GP PUMP PACKING / EXTRACTION KIT - COMPLETE .....	209
FOOT-CONTROLLED PRESSURE VALVE .....	116	GUN ASSEMBLY - 910 SPOT SPRAY .....	288
FOOT VALVES - SUCTION - ST35 / ST35R.....	160	GUTTER CLEANER ATTACHMENT .....	134
FRAMES, DIRECT DRIVE.....	275	<b>H</b>	
FUEL CAPS.....	276	HAND CLEANER - VICTOR WATERLESS COMMAND-O WITH PUMICE.....	126
FUEL CONDITIONER AND SOOT REMOVER .....	249	HANDLES - FIBERGLASS "SUPER HANDLES" .....	117
FUEL NOZZLES - CHECK VALVE - "SNAP" .....	259	HEAVY-DUTY SWIVELS.....	288
FUEL NOZZLES - DELAVAN - 45° & 60° .....	255	HEX COUPLINGS - BRASS.....	150
FUEL NOZZLES - DELAVAN - 70° .....	256	HEX COUPLINGS - REDUCING - BRASS .....	150
FUEL NOZZLES - DELAVAN - 80° .....	257		
FUEL NOZZLES - DELAVAN - 90° .....	258		
FUEL NOZZLE TRAY .....	251		
FUEL PUMP - BECKETT CLEAN CUT .....	249		

HEX NIPPLES - DOUBLE - BRASS..... 150  
 HEX PIPE PLUGS - HIGH PSI - STEEL..... 156  
 HEX REDUCING NIPPLES - BRASS..... 150  
 HOBBY GUN, LANCE AND HOSE..... 135  
 HOBBY HOSE..... 140  
 HONDA ENGINE PARTS..... 238  
 HOSE - 1-WIRE..... 136  
 HOSE - 2-WIRE..... 136  
 HOSE - A+ 1- & 2-WIRE WITH COUPLING AND  
 PLUG, NON-MARKING..... 138  
 HOSE - A+ 1-WIRE GRAY WRAPPED COVER..... 138  
 HOSE - A+ / TUFF-FLEX - 1-WIRE SMOOTH COVER,  
 NON-MARKING..... 138  
 HOSE - A+ / TUFF-FLEX - 2-WIRE SMOOTH COVER,  
 NON-MARKING..... 139  
 HOSE BARBS - BRASS..... 153  
 HOSE BARBS - BRASS CHECK BARBS..... 153  
 HOSE BARBS - ORIFICED..... 153  
 HOSE BARBS - SWIVEL - LOW PRESSURE..... 153  
 HOSE BEND RESTRICTORS..... 140  
 HOSE CLAMPS..... 155  
 HOSE - LEGACY 1- & 2-WIRE, NON-MARKING..... 137  
 HOSE - LEGACY 1- & 2-WIRE WITH COUPLING  
 AND PLUG..... 137  
 HOSE - LEGACY 1-WIRE SMOOTH COVER, NON-  
 MARKING..... 137  
 HOSE - LEGACY HIGH-PRESSURE..... 136  
 HOSE REELS - AP..... 123  
 HOSE REELS - COXREELS..... 124  
 HOSE REELS - GENERAL PUMP  
 A-FRAME HOSE REELS..... 125  
 HOSE REELS - GENERAL PUMP SWIVELS..... 125  
 HOSE REELS - LEGACY PIVOT & FIXED BASE..... 122  
 HOSE REELS - LEGACY STACKABLE..... 121  
 HOSE REELS - LEGACY SWIVELS..... 122  
 HOSES - CONNECTOR / CAR WASH BAY, 12'-25'..... 281  
 HOSE - WHITEWATER® COMBINATION  
 STEAM HOSE..... 140  
 HOT BOX - OIL-FIRED..... 120  
 HOUR METERS FOR GASOLINE ENGINES..... 237  
 HYPRO ROLLER PUMPS..... 285

**I**

INDICATOR LIGHTS..... 273  
 INDUSTRIAL CHEMICAL SPRAYER..... 287  
 INSULATION AND RIGID DISC / DONUTS..... 260  
 INTERPUMP / GENERAL PUMP -  
 CAR WASH SOLID-SHAFT PUMP..... 196  
 INTERPUMP / GENERAL PUMP -  
 EZ SERIES HOLLOW-SHAFT..... 197  
 INTERPUMP / GENERAL PUMP - HOLLOW-SHAFT... 197  
 INTERPUMP / GENERAL PUMP KIT  
 SELECTION CHART..... 198  
 INTERPUMP / GENERAL PUMP KITS - GENUINE..... 199  
 INTERPUMP / GENERAL PUMP KITS -  
 GENUINE (CONTINUED)..... 200  
 INTERPUMP / GENERAL PUMP -  
 LARGE FRAME SOLID-SHAFT PUMP..... 196  
 INTERPUMP / GENERAL PUMP -  
 SERIES "44" (EZ SERIES) SOLID-SHAFT PUMP..... 196  
 INTERPUMP / GENERAL PUMP -  
 SOLID-SHAFT PUMPS..... 195  
 INTERPUMP / GENERAL PUMP -  
 TSF SOLID-SHAFT PUMP..... 196  
 INTERPUMP / GENERAL PUMP -  
 TX SERIES HOLLOW-SHAFT..... 197  
 INTERPUMP / GENERAL PUMP -  
 TX SOLID-SHAFT PUMP..... 196  
 INTERPUMP / GENERAL PUMP -  
 V-PACKING INSERTION TOOL KIT..... 208  
 INTERPUMP PACKING / EXTRACTION TOOL..... 208

**J**

JETTER PULSE VALVES..... 207  
 JROD MULTI-NOZZLE HOLDER..... 179  
 JUNCTION BOXES..... 268

**K**

KEYED IGNITION SWITCH - 12V DC..... 239

**L**

LANCE HANDLES / ACCESSORIES..... 133  
 LANCES - FLEX..... 280  
 LEGACY "BEST" SPRAY GUN..... 127  
 LEGACY HD PUMP..... 181  
 LEGACY HD PUMP - FOG NEMA SERIES..... 184  
 LEGACY HD PUMP - GF & GFP SERIES..... 184

LEGACY HD PUMP - GM SERIES.....	182	LOCKNUT FITTINGS - HEX-HEAD PLUGS.....	154
LEGACY HD PUMP - GP & GPP SERIES.....	184	LOCKS FOR METER BOXES.....	279
LEGACY HD PUMP - GS SERIES.....	184	LONG RANGE TIP.....	289
LEGACY HD PUMP - GT SERIES.....	182	LOW-FLOW BRASS PRESSURE REGULATOR.....	289
LEGACY HD PUMP - GX SERIES.....	181		
LEGACY HD PUMP - HY SERIES.....	185	<b>M</b>	
LEGACY HD PUMP - READY TO GO SERIES.....	182	M23 TRIGGER VALVES.....	287
LEGACY HD PUMP REPAIR - CERAMIC PLUNGER KITS.....	194	M407 TRIGGER GUN.....	127
LEGACY HD PUMP REPAIR - COMPLETE KITS.....	194	MISCELLANEOUS PARTS.....	277
LEGACY HD PUMP REPAIR KIT SELECTION CHART..	191	ML320.....	130
LEGACY HD PUMP REPAIR KIT SELECTION CHART (CONTINUED).....	192	MOLDED PLASTIC FLOAT TANKS.....	275
LEGACY HD PUMP REPAIR KIT SELECTION CHART (CONTINUED).....	193	MOTOR CONTACTORS - COILS & THERMAL OVERLOADS.....	266
LEGACY HD PUMP REPAIR - PLUNGER OIL SEAL KITS.....	195	MOTORS - A.O. SMITH - PRESSURE WASHER - OPEN DRIP PROOF (ODP).....	241
LEGACY HD PUMP REPAIR - SEAL KITS.....	193	MOTOR STARTER WITH SEALED BOX - MANUAL.....	267
LEGACY HD PUMP REPAIR - VALVE KITS.....	194	MOTORS - TOTALLY ENCLOSED FAN COOLED (TEFC).....	241
LEGACY INDUSTRIAL GUN AND LANCE COMBO.....	135	MOTORS - WEG - PRESSURE WASHER - OPEN DRIP PROOF (ODP).....	242
LEGACY "INDUSTRIAL" SPRAY GUN.....	127	MV925 GUN AND LANCE COMBO.....	135
LEGACY OVAL MOLDED GRIP LANCES.....	132	MV925 GUN, LANCE AND HOSE COMBO.....	135
LEGACY PUMP.....	187	MV 925 OPEN GUN.....	130
LEGACY PUMP - GBP & GB SERIES.....	182	MV925 TRIGGER GUN.....	127
LEGACY PUMP - HFR SERIES.....	183	MV LANCE HANDLE.....	134
LEGACY PUMP - HHP SERIES.....	183		
LEGACY PUMP - KKV SERIES.....	185	<b>N</b>	
LEGACY PUMP - NLT SERIES.....	183	NIPPLES - BRASS - OPEN & CLOSE.....	151
LEGACY PUMP - NMT SERIES.....	183	NIPPLES - HEX - HIGH PSI - STEEL.....	155
LEGACY PUMP REPAIR KITS.....	189	NIPPLES - JIC X-PIPE.....	151
LEGACY PUMP REPAIR KIT SELECTION CHART.....	188	NIPPLES - JLC - BRASS.....	152
LEGACY PUMP REPAIR TOOL KIT.....	188	NIPPLES - PIPE - MPT - HIGH PSI - ZINC.....	157
LEGACY PUMP - TMH SERIES.....	187	NOZZLE FAN SELECTION.....	164
LEGACY PUMP - TML SERIES.....	185	NOZZLE FILTERS - 1/4" HIGH-PRESSURE.....	177
LEGACY PUMP - TTV SERIES.....	185	NOZZLE HEAD - DOUBLE.....	178
LEGACY PUMP - WJG SERIES.....	186	NOZZLE HOLDER GROMMET.....	167
LEGACY PUMP - WJH-F & WJH SERIES.....	186	NOZZLE HOLDER / HEAD - ST-56 ROLLOVER.....	178
LEGACY PUMP - WMG 1 SERIES.....	187	NOZZLE HOLDER - ROLLOVER - TWIST TYPE.....	179
LEGACY PUMP - WMG SERIES.....	186	NOZZLE HOLDER - ST-51N ADJUSTABLE.....	178
LEGACY SQUARE MOLDED GRIP LANCES.....	132	NOZZLE HOLDER - ST-330 - SWIVELING.....	178
LEGACY SUPERLITE STAINLESS-STEEL DUAL LANCE.....	131	NOZZLE PROTECTOR / COUPLER.....	180
LEGACY VENTED LANCES.....	133	NOZZLE PROTECTOR - SLIP-ON.....	180
		NOZZLE PROTECTOR - ST-10.....	173

NOZZLES - 1/4" VEEJET - BROAD SPRAY STAINLESS-STEEL..... 170

NOZZLES - 1/4" VEEJET - LOW-PRESSURE - BRASS 171

NOZZLES - 3650 & 5100 PSI TURBO ..... 175

NOZZLES - A+ / AP REVOLUTION TURBO ..... 173

NOZZLES - A+ MULTI-FAN..... 177

NOZZLES - ADJUSTABLE..... 179

NOZZLES - DUO-REG ..... 177

NOZZLE SETS - GP - QC 4 & 5 PACKS - COLOR-CODED..... 166

NOZZLE SETS - LEGACY - QC 4 & 5 PACKS - COLOR-CODED..... 165

NOZZLES - HL250 VARI HI-LOW ANGLE ..... 178

NOZZLE SIZE SELECTION CHART ..... 164

NOZZLES - LEGACY - QC - 1/4" COLOR-CODED ..... 165

NOZZLES - LEGACY REVOLUTION TURBO..... 172

NOZZLES - MEG - 1/4" MALE THREADS ..... 168

NOZZLES - MEG - 1/4" - M-STYLE..... 167

NOZZLES - MEG - 1/8" - "WASHJET" ..... 169

NOZZLES - MV ROTOJET 3700 & 5800 TURBO ..... 174

NOZZLES - MV TRIPLE-FUNCTION ..... 176

NOZZLES - QC - 1/4" - Q-STYLE ..... 166

NOZZLES - QC "WASH JET" ..... 170

NOZZLES - ROTOJET 2500..... 177

NOZZLES - SOAP ..... 172

NOZZLES - SOAP NOZZLES ..... 167

NOZZLES - ST-357 & ST-457 TURBO..... 175

NOZZLES - STEAM ..... 179

NOZZLES - STEAM ..... 179

NOZZLES - TURBO - A+ NOZZLE KIT..... 173

NOZZLES - TURBO - IDK & DK SERIES - DIRT KILLER..... 176

NOZZLES - TURBO MV ROTATING SOFT / HARD ..... 176

NOZZLES - VARIABLE ANGLE ..... 178

NOZZLES - VIPER ROTATING ..... 176

NOZZLE SYSTEM - TIP JET ..... 171

NOZZLE SYSTEM - TIP JET ADAPTER CAPS..... 172

NOZZLE SYSTEM - TIP JET NOZZLE BODIES ..... 171

NOZZLE SYSTEM - TIP JET RETAINER ..... 172

NOZZLE SYSTEM - TIP JET RETAINER CAPS ..... 172

NOZZLE SYSTEM - TIP JET STRAINERS ..... 172

NOZZLES - ZRMAX & ZROTOMAX ROTATING ..... 176

NYLON PRESSURE REGULATOR ..... 289

**O**

O-RINGS ..... 145

OVERLOAD RELAYS FOR CONTACTORS ..... 265

**P**

PA LINEAR GUN ..... 129

PA TRIGGER GUN..... 129

PERFORMANCE TABLES ..... 285

PISTON PUMPS - HYPRO..... 207

PLASTIC DIP TUBE ASSEMBLY..... 276

PLASTIC FITTINGS..... 291

PLUGS - ALLEN HEAD ..... 154

PLUGS - HEX HEAD..... 154

POWER CORD - MOLDED ..... 265

POWERED DAMPER ..... 254

PRESSURE GAUGE - FUEL / OIL ..... 235

PRESSURE GAUGES - ABS, CORROSION-RESISTANT 236

PRESSURE GAUGES - PORT KIT ..... 235

PRESSURE GAUGES - STAINLESS-STEEL ..... 236

PRESSURE GAUGES / TEMPERATURE TEST SET..... 237

PRESSURE GAUGES - VACUUM - STAINLESS-STEEL 236

PRESSURE GAUGES - 100 SERIES PNEUMATIC..... 235

PRESSURE LOOP - 2-WIRE ..... 139

PRESSURE REGULATOR, WATER 2-WAY ..... 236

PRESSURE RELIEF VALVE - EASY-START, HIGH PSI.. 235

PRESSURE RELIEF VALVE - EASY-START, LOW PSI... 235

PRESSURE RELIEF VALVES..... 234

PRESSURE RELIEF VALVES - SR/S3 ..... 221

PRESSURE RELIEF VALVES - TIMAX..... 221

PRESSURE RELIEF VALVES - VS 200 / 180, HIGH PSI..... 222

PRESSURE RELIEF VALVES - VS 220..... 222

PRESSURE RELIEF VALVES - VS 350, HIGH PSI ..... 222

PRESSURE RELIEF VALVES - VS 500, HIGH PSI..... 222

PRESSURE SWITCHES - COMPACT & PS-6 SS..... 262

PRESSURE SWITCHES - LEGACY..... 262

PRESSURE SWITCHES - PA - PR1 - RED..... 262

PRESSURE SWITCHES - PR16 - BLACK..... 262

PROPANE GAS HOSE..... 253

PROPANE TANKS..... 253

PROPORTIONER FLOAT VALVE SYSTEMS - AQUA MASTER™ MODEL 440 ..... 284

PROPORTIONERS & ACCESSORIES - DEMA ..... 284

PTO GEARED MULTIPLIER.....	210	REPLACEMENT ORFICES .....	178
PULLEY BUSHINGS.....	243	ROCKER SWITCHES.....	271
PULLEYS .....	243	RUBBER PARTS.....	276
PULLEYS .....	244	RUPTURE DISKS.....	234
PULSE HOSE.....	140		
PUMP - AIR-OPERATED - FLOJET.....	278	<b>S</b>	
PUMP LUBE.....	209	SANDBLASTERS - INDUSTRIAL.....	115
PUMP LUBE.....	209	SANDBLAST HEAD - PROFESSIONAL .....	114
PUMP OIL.....	209	SANDBLAST HOSE .....	115
PUMP PACKING EXTRACTOR HAMMER & SOCKETS.....	208	SANDBLAST KIT - TUNGSTEN CARBIDE NOZZLE HEAD - INDUSTRIAL.....	114
PUMP PACKING & SEAL KITS - GENERIC - A+ .....	207	SANDBLAST NOZZLE TIPS.....	114
PUMP PARTS AND TOOLS.....	207	SAND NOZZLE .....	115
PUMP RAILS - LEGACY & LEGACY HD.....	187	SEWER HOSE .....	144
PUMPS - AIR-DRIVEN - FLOJET .....	278	SEWER / TUBE CLEANING NOZZLES - 5000 PSI .....	163
PUMP TECHNICAL INFORMATION.....	211	SEWER / TUBE CLEANING NOZZLES - ST-49 & "MINI".....	163
PUMPTECH PUMP.....	210	SLUDGE SUCKER - ST-36 PIT BOSS.....	116
PUMP TOOLS - EXTRACTOR PLIERS & DENTAL PICK.....	208	SMALL ENGINE TEST EQUIPMENT .....	242
		SMOKE TESTER - DIAGNOSTIC TOOL.....	251
<b>Q</b>		SOLENOID VALVES - CFA - SS & BRASS .....	282
Q.C. SOCKETS & PLUGS - A+ BRASS.....	148	SOLENOID VALVES - CFA - SS & BRASS .....	282
Q.C. SOCKETS & PLUGS - DOUBLE SHUT-OFF.....	148	SOLENOID VALVES - KIP - SS & BRASS .....	283
Q.C. SOCKETS & PLUGS - EXTENDED TWIST SEAL.....	147	SOLENOID VALVES WITH BUILT-IN STRAINERS.....	283
Q.C. SOCKETS & PLUGS - FOSTER .....	145	SPRAYERS - B&G POLY-MOLDED.....	119
Q.C. SOCKETS & PLUGS - FOSTER DOUBLE SHUT-OFF .....	148	SPRAYERS - CHAPIN AIR-POWERED .....	119
Q.C. SOCKETS & PLUGS - LEGACY - BRASS & STEEL.....	145	SPRAY-FLEX™ FLEX WAND .....	134
Q.C. SOCKETS & PLUGS - LEGACY - STAINLESS-STEEL.....	145	SPRAYMAX TRIGGER GUN.....	287
Q.C. SOCKETS & PLUGS - MM22 - TWIST SEAL .....	147	ST-810 SUTTNER TRIGGER GUN.....	128
Q.C. SOCKETS & PLUGS - MM22 - TWIST SEAL .....	147	ST-1500H OPEN GUN .....	130
Q.C. SOCKETS & PLUGS - SNAPTITE SERIES.....	146	ST-1500 SUTTNER TRIGGER GUN.....	128
Q.C. SOCKETS & PLUGS - ST SERIES.....	146	ST-2000 SUTTNER TRIGGER GUN.....	128
		ST-2305 SUTTNER TRIGGER GUN.....	128
<b>R</b>		ST-2305 SUTTNER TRIGGER GUN.....	128
RAIN SUIT, 2 PIECE.....	119	ST-2315 SUTTNER TRIGGER GUN.....	128
REDUCING BUSHING - HIGH PSI - STEEL .....	156	ST-2605 SUTTNER TRIGGER GUN.....	128
REFERENCE / CALCULATION GUIDE.....	241	ST-2700 SUTTNER TRIGGER GUN.....	128
REGULATING RELIEF VALVE.....	222	ST-2720 SUTTNER TRIGGER GUN.....	127
REGULATOR VALVE - STEAM.....	234	STAINLESS-STEEL FLOAT TANK.....	275
RELAYS.....	265	STARTER SOLENOID - 12V DC .....	239
RELAY SWITCH.....	265	STEAM LANCE .....	115
REPLACEMENT FUEL CAP .....	275	STRAINERS / TANK SCREEN.....	160
		STRAINERS - Y TRAP.....	159



SURFACE CLEANER NOZZLE RECOMMENDATION ....	112	TEES - STREET TEE - HIGH PSI - STEEL.....	156
SURFACE CLEANERS - A+ - 21" & 24" .....	110	TEMPERATURE GAUGE .....	237
SURFACE CLEANERS - "CYCLONE" ROTARY FLAT ....	111	TEMPERATURE GAUGE - THERMWELL.....	237
SURFACE CLEANERS / DUCT CLEANER - MOSMATIC .....	114	THERMAL RELIEF VALVES.....	234
SURFACE CLEANERS - ECONOMY - 8" & 15" .....	110	THERMAL RELIEF VALVES - COMPACT.....	233
SURFACE CLEANERS - GP - FLAT 12", 18" & 20" .....	111	THERMAL RELIEF VALVES - TRV .....	234
SURFACE CLEANERS - WHISPER WASH FLAT .....	112	THERMOSTAT - ADJUSTABLE - FLOW-THRU.....	272
SUTTNER DUAL LANCES .....	132	THERMOSTAT - ADJUSTABLE WITH PROBE .....	272
SUTTNER PUSH AND PULL LANCE .....	133	THREAD LOCK PRODUCTS.....	120
SUTTNER TRIGGER GUN .....	129	THROTTLE CONTROL - SPEEDMASTER.....	237
SWITCH BOX - RAINTITE .....	268	TIMER.....	269
SWITCHES / CONTACT BLOCKS - PUSH BUTTON - CUTLER-HAMMER.....	264	TRANSFORMER FUSES .....	279
SWITCHES - THERMAL - HI-LIMIT - SNAP.....	263	TRANSFORMERS .....	279
SWITCHES - THERMAL - HI-LIMIT - SNAP WITH LEADS.....	263	TRANSFORMERS - STEP-DOWN .....	267
SWITCHES - TOGGLE - MOTOR CONTROL.....	263	TRIGGER-CONTROL SPRAY LANCES.....	288
SWITCHES - TOGGLE - PUSH BUTTON.....	263	TRIGGER GUN - RB65 WASH GUN.....	280
SWITCH - ROTARY - 8-POSITION.....	279	TRIGGER-JET SPRAY LANCES - TEEJET.....	289
SWIVELS - 90° .....	148	TUBING - CLEAR PVC.....	142
SWIVELS - A+ LONG BODY STYLE.....	149	TUBING - CLEAR REINFORCED PVC.....	142
SWIVELS - BALL BEARING.....	149	TUBING - HEAVY-DUTY VINYL .....	142
SWIVELS - GUN - MOSMATIC .....	149	TURBINE SERIES GUNS.....	288
SWIVELS - JIC.....	151	TWIN-DIAPHRAGM SPOT SPRAY PUMP .....	290
SWIVELS - LOW-PRESSURE - CAR WASH.....	280		
SWIVELS - MEDIUM-PRESSURE - CAR WASH.....	280	<b>U</b>	
SWIVELS - RIGHT ANGLE .....	148	UNDERBODY WAND ASSEMBLY - SELF SERVE .....	114
SWIVELS - STAINLESS-STEEL .....	149	UNDERCARRIAGE CLEANER.....	113
SWIVELS - STAINLESS-STEEL BALL BEARING .....	149	UNDERCARRIAGE CLEANER & ROOF SURFACE CLEANER .....	113
SWIVELS - STAINLESS-STEEL, HIGH-PRESSURE AND ECONOMY BRASS.....	149	UNLOADER VALVES - 22900A PRESSURE ACTUATED SERIES.....	220
		UNLOADER VALVES - APM PRESSURE ACTUATED SERIES .....	220
<b>T</b>		UNLOADER VALVES - APR SERIES .....	214
TAPE - SHIPPING TAPE AND DISPENSER.....	119	UNLOADER VALVES - AR BOLT-ON.....	220
TAPE - TEFLON® THREAD SEALING .....	119	UNLOADER VALVES - CONTROL SET "W" SERIES.....	217
TAPE - VINYL ELECTRICAL .....	273	UNLOADER VALVES - FLOW-ACTUATED.....	221
TEES - 3 CONNECTS - HIGH PSI - FORGED .....	156	UNLOADER VALVES - GYMATIC - 3/B & VR35 3/B SERIES .....	220
TEES - BANDED - FPT - 3 CONNECTS - GALVANIZED.....	157	UNLOADER VALVES - HM MODEL.....	218
TEES - BRANCH-BRASS.....	152	UNLOADER VALVES - HYPRO-STYLE .....	218
TEES - FPT - FORGED-BRASS .....	152	UNLOADER VALVES - KITS FOR K / ZK SERIES.....	217
TEES - STREET-BRASS .....	152	UNLOADER VALVES - K / ZK SERIES .....	218

UNLOADER VALVES - MG4000 SERIES ..... 221

UNLOADER VALVES - MOUNTING BLOCK ..... 222

UNLOADER VALVES - PULSAR RV SERIES ..... 215

UNLOADER VALVES - ST-230 ..... 219

UNLOADER VALVES - ST-261 SERIES ..... 219

UNLOADER VALVES - ST-280 ..... 219

UNLOADER VALVES - UU1 UNIVERSAL ..... 213

UNLOADER VALVES - VB7 SERIES ..... 215

UNLOADER VALVES - VB9 / VB10 TRAPPED  
PRESSURE SERIES ..... 217

UNLOADER VALVES - VB75 / VB135 SERIES ..... 216

UNLOADER VALVES -  
VB80 / 400 STAINLESS-STEEL ..... 216

UNLOADER VALVES - VB85 / 280 SERIES ..... 216

UNLOADER VALVES - VB130/135 SERIES ..... 216

UNLOADER VALVES - VB200 HIGH-VOLUME SERIES .....  
216

UNLOADER VALVES - VB350 / VB7 SERIES ..... 217

UNLOADER VALVES - VBT SERIES ..... 213

UNLOADER VALVES - VR53 ..... 214

UNLOADER VALVES - VR54/56 ..... 214

UNLOADER VALVES - VR56/VBA35 SERIES ..... 214

UNLOADER VALVES - VRT3 SERIES ..... 215

UNLOADER VALVES -  
VRT100 HIGH-VOLUME SERIES ..... 215

UNLOADER VALVES - YU HIGH VOLUME ..... 218

**V**

VAC SWITCHES - BURNER CONTROL ..... 262

VACUUM ACCESSORIES ..... 280

VACUUM MOTORS - A+ / AP ..... 281

VACUUM MOTORS - AMETEK-LAMB ..... 281

VALVE - 3-WAY - ERIE MOTORTROL® ..... 284

V-BELTS - SUPER "GRIPNOTCH" ..... 243

VOLTAGE REGULATOR - HEAVY-DUTY 15V ..... 239

VOLTMETERS ..... 237

**W**

WASH BAY ACCESSORIES - STAINLESS-STEEL ..... 279

WATER BROOM 16" ..... 113

WIRE LOOMS - USED FOR WIRING HARNESSSES ..... 273

**XYZ**

X-JET LONG RANGE NOZZLE ..... 179

YAMADA PUMPS ..... 212

YAMADA PUMPS DIAPHRAGM KITS ..... 212



## Hotsy Dealers Provide Pressure Washer Maintenance & Parts

Your Hotsy dealer has ways to help you enhance every aspect of your cleaning operation, so you can clean faster and more efficiently than ever. You need maximum productivity and minimum operating costs and every minute of production you can get. Keeping your pressure washer repaired and serviced so it will run properly is the smart thing to do. With over 175 local sales and service centers you can count on your local Hotsy dealer for pressure washer service and maintenance support when you need it.



HOTSY.COM

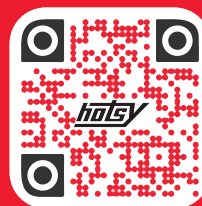

**SCAN TO WATCH  
THE VALUE OF A  
HOTSY DEALER.**

Your Hotsy dealer is there to help, advise, and make your cleaning fast and economical.



**SCAN TO FIND YOUR HOTSY DEALER.**  
 Our dealer network spans the U.S. and Canada, providing you with close, immediate expert assistance for your cleaning needs.

## THE BRAND THE PROS USE

**AT HOTSY WE MAKE GREAT PRESSURE WASHERS.** They come with the best warranties in the industry and are backed with expert service, great parts and detergents made specifically for your cleaning needs. Hotsy delivers the most rugged and durable industrial pressure washers on the market. We are proud of our network of authorized **Hotsy dealers** throughout North America who will help you select the best equipment and accessories for your cleaning job. Our dealers provide on-site cleaning evaluations and next day service calls by factory certified technicians. Excellent warranties, superior performance and ETL safety certified. Buy a Hotsy and you'll have peace of mind knowing you have a product built to last.

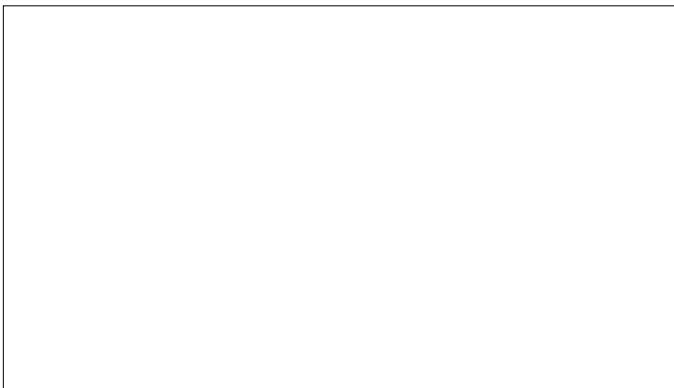

### HOTSY.COM

 [facebook.com/HotsyCleaningSystems](https://facebook.com/HotsyCleaningSystems)

 [twitter.com/TheHotsyMan](https://twitter.com/TheHotsyMan)

 [youtube.com/HotsyCleaningSystems](https://youtube.com/HotsyCleaningSystems)

 [instagram.com/HotsyCleaningSystems](https://instagram.com/HotsyCleaningSystems)

 [linkedin.com/company/hotsy-corp](https://linkedin.com/company/hotsy-corp)

 **Get Hotsy Email:** [Bit.ly/GetHotsy](https://bit.ly/GetHotsy)