



The LH Electric series are the most innovative pressure washers in the industry. With features such as a rugged 1.25" steel tubing frame and stainless steel side panels, these products are ideal for industrial and commercial cleaning applications. RAMTEQ's top quality, durable construction provides years of reliability. Designed with the user in mind, RAMTEQ's modular technology supports low operational costs through easy, efficient and effective service and upgrade paths. RAMTEQ products designed and built for performance, dependability and low total cost of ownership.



LH750
BELT DRIVE
ELECTRIC

The LH Series

WORKS

BEST UNDER PRESSURE



The LH Series comes with your choice of either 4 pneumatic tires or 2 pneumatic tires and a rear support tine.



LH300
DIRECT DRIVE
ELECTRIC

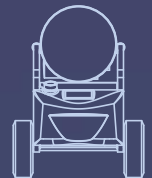
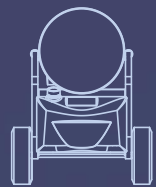

The LH Series is available in two different sizes, depending on coil. Both are the same length, but the large coil unit is 2 inches wider and 1 inch taller.

MODULAR DESIGN

CROSS-LINKED
POLYETHYLENE
FUEL TANKS

WAYNE® BURNER

VARIOUS
WHEEL / MOUNTING
CONFIGURATIONS

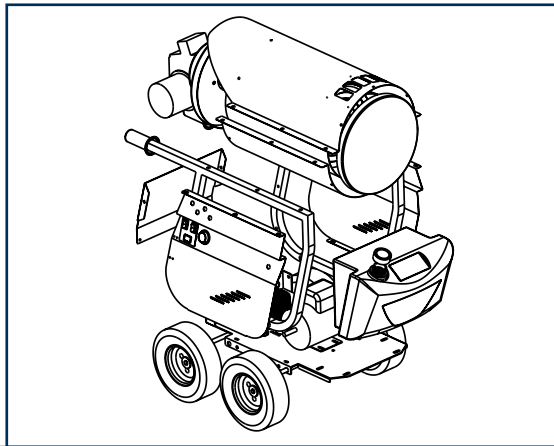

SPLIT STAINLESS-STEEL
OUTER COIL WRAP

TRIPLEX
PLUNGER PUMPS

TEXTURED
POWDERCOAT

FULL CHASSIS
UNDERCARRIAGE

SPECIFICATIONS: DIRECT DRIVE

	150 SERIES (SMALL COIL)	200 SERIES (SMALL COIL)	300 SERIES (SMALL COIL)	500 SERIES (SMALL COIL)
HORSEPOWER	1.5 HP	2.0 HP	3.0 HP	5.0 HP
VOLTAGE/CYCLE/PHASE	115/60/1	115/60/1	115/60/1	208-230/60/1
WATER PUMP VOLUME	2.0 GPM (7.6 LPM)	2.0 GPM (7.6 LPM)	3.0 GPM (11.4 LPM)	3.5 GPM (13.3 LPM)
OPERATING PRESSURE	1000 PSI (68.9 BARS)	1400 PSI (96.5 BARS)	1500 PSI (103.5 BARS)	2000 PSI (137.9 BARS)
BTU⁵ PER HOUR	195,000	195,000	270,000	270,000
DIMENSIONS	45.5"L, 27.5"W, 36.3"H	45.5"L, 27.5"W, 36.3"H	45.5"L, 27.5"W, 36.3"H	45.5"L, 27.5"W, 36.3"H
GROSS SHIPPING WEIGHT	420 LBS	425 LBS	430 LBS	435 LBS

SPECIFICATIONS: BELT DRIVE

	150 SERIES (SMALL COIL)	200 SERIES (SMALL COIL)	300 SERIES (SMALL COIL)	500 SERIES (LARGE COIL)	600 SERIES (LARGE COIL)	750 SERIES (SMALL COIL)	1000 SERIES (LARGE COIL)
HORSEPOWER	1.5 HP	2.0 HP	3.0 HP	5.0 HP	6.0 HP	7.5 HP	10.0 HP
VOLTAGE/CYCLE/PHASE	115/60/1	115/60/1	115/60/1	208-230/60/1	208-230/60/1	208-230/60/1	208-230/60/3
WATER PUMP VOLUME	2.0 GPM (7.6 LPM)	2.0 GPM (7.6 LPM)	3.0 GPM (11.4 LPM)	4.0 GPM (15.2 LPM)	4.0 GPM (15.2 LPM)	3.5 GPM (13.3 LPM)	4.8 GPM (18.2 LPM)
OPERATING PRESSURE	1000 PSI (68.9 BARS)	1400 PSI (96.5 BARS)	1500 PSI (103.5 BARS)	2,000 PSI (137.9 BARS)	2,000 PSI (137.9 BARS)	3000 PSI (206.8 BARS)	3000 PSI (206.8 BARS)
BTU⁵ PER HOUR	195,000	195,000	270,000	350,000	350,000	270,000	350,000
DIMENSIONS	45.5"L, 27.5"W, 36.3"H	45.5"L, 27.5"W, 36.3"H	45.5"L, 27.5"W, 36.3"H	45.5"L, 29.5"W, 37.3"H	45.5"L, 29.5"W, 37.3"H	45.5"L, 27.5"W, 36.3"H	45.5"L, 29.5"W, 37.3"H
GROSS SHIPPING WEIGHT	440 LBS	445 LBS	450 LBS	535 LBS	535 LBS	535 LBS	580 LBS

LH STANDARD FEATURES:

- TRIPLEX PLUNGER PUMPS
DIRECT DRIVE OR BELT DRIVEN
- BURNER - WAYNE®
OIL FIRED (NO. 1 & NO. 2 DIESEL,
KEROSENE, NO. 1 HOME HEATING OIL)
- HIGH PERFORMANCE MOTORS
- WHEEL CONFIGURATIONS
4 PNEUMATIC AXLE WHEELS
2 PNEUMATICS, 1 FRONT TIRE
- DETERGENT INJECTION
- ADJUSTABLE THERMOSTAT
- 1¼" SQUARE TUBULAR STEEL CHASSIS
WITH TEXTURED POLYESTER POWDER COAT
- FUEL TANK, 7.5 GALLON CAPACITY
WITH NON-GAUGED POLY CAP
- SPLIT STAINLESS-STEEL COIL WRAP
- SINGLE NOZZLE (15°)
- TRIGGER GUN CONTROL
- 50' HOSE — 3/8" ID
INSULATED SINGLE OR DOUBLE BRAID HOSE
WITH SWIVEL CONNECTOR
- COIL: SCHEDULE 80

LH OPTIONAL FEATURES:

- UPSTREAM CHEMICAL METERING
WITH POLYETHYLENE FLOAT TANK
AND SINGLE LANCE WAND
REPLACES DOWNSTREAM INJECTION
AND DUAL LANCE WAND
- AUTO START/STOP
TIME DELAY SHUTDOWN
INCLUDES HOURMETER
- 4 NOZZLES (0°, 15°, 25°, 40°)
- RACOR FUEL FILTER

We continue to evolve and enhance our product offerings and therefore pictures, features and specifications reflected on this brochure may vary slightly from current product. These may also vary slightly based on component and manufacturing tolerances. See authorized distributors for manufacturer installed options.



14275 NORTHWEST FREEWAY
HOUSTON, TEXAS 77040

PHONE: 713.983.6000
FAX: 713.983.6405
WWW.RAMTEQ.COM